

# MYCOM

## Compound 2-stage Screw Compressor 2016\*\*C Instruction Manual

2016LLC / 2016LMC / 2016LSC  
2016MMC / 2016MSC / 2016SSC



### CAUTION

Before operating, servicing, or inspecting this product, read this manual thoroughly to fully understand the contents.

Keep this Instruction Manual in a safe, designated place for future reference whenever the manual is needed.

Specifications of this product and contents of this manual are subject to change without prior notice due to technical improvements, and the like.

## Preface

Thank you for purchasing the **MYCOM** compound 2-stage screw compressor 2016\*\*C (hereinafter referred to as "this product").

This Instruction Manual (hereinafter referred to as "this manual") provides safety information and operation and maintenance procedures, so that users correctly understand how to handle this product and, as a result, can use it safely and efficiently. This manual is applicable to the following models:

2016LLC-\*B\*-51, 2016LMC-\*B\*-51, 20162LSC-\*B\*-51, 2016MMC-\*B\*-51, 2016MSC-\*B\*-51, 2016SSC-\*B\*-51  
 2016LLC-\*B\*-61, 2016LMC-\*B\*-61, 20162LSC-\*B\*-61, 2016MMC-\*B\*-61, 2016MSC-\*B\*-61, 2016SSC-\*B\*-61  
 \* -51 (-61) may not be written. For more information, see 2.2 "Model designation of the compressor" in this manual Chapter 2.

Before installing or using this product, make sure to read this manual.

Keep this manual in a safe place near this product for quick reference.

## Revision History

Title		Document No.	First edition issue date
2016**C Instruction Manual		2201LZJE-HO-C6-N_2015.05.	Dec. 16, 2013
Revision No.	Issue date	Major Contents of revisions	Created / approved by:
-	Jun. 30, 1974	Issuance of 2016C first edition	S. Yamamoto
-	Oct.01, 1983	Newly issued as 1612**C/2016**C edition.	S. Yamamoto
-	Jun. 30, 1993	Revision of 1612**C/2016**C (correction of errors, etc.)	S. Yamamoto
-	Jun. 30, 1996	Reviewed pursuant to the Product Liability Law, established June 1994	Ikehara / Shozu
00	Dec. 16, 2013	Overall review associated with reissue as electronic document, document No. change	Ikehara, / Hirao
<b>01</b>	<b>May 01, 2015</b>	<b>Modified the constitution of Chapter 4 and Chapter 5. Correction of describing, etc.</b>	<b>Ikehara / Muta</b>

# Warranty and Disclaimer

## Warranty

MAYEKAWA shall repair or replace parts of this product for no charge if any failure resulting from defects in design or manufacture occurs, under normal use with the purpose and method that are in accordance with the specifications of this product and this manual, within the warranty period.

The warranty period is "12 months from factory shipment of this product". If there is a separate agreement, that agreement shall prevail in principle.

MAYEKAWA is not liable for production or man-made disaster compensation due to malfunction or damage of this product.

## Disclaimer of Warranty

Although MAYEKAWA warrants the clauses mentioned above, the following clauses are exempted.

- Malfunction or damage of this product caused by natural disaster, or other accidental forces (such as fire, thunderbolt, windstorm, intense rainfall, flood, tidal wave, earthquake, land subsidence, etc.).
- Malfunction or damage caused by misuse described below.
  - Malfunctions, damage, or deterioration of this product due to abnormal or improper use (including improperly storing this product outdoors or under too hot/humid conditions, unexpected inspections, tests, operations, too frequent liquid flow-back operation\*, and too frequent start-stop cycles, etc.).
  - Malfunction or damage caused by devices or equipments not provided by MAYEKAWA including operation control methods of those devices.
  - Malfunction or damage caused by refrigerants, gases, or refrigerant oils, and operating conditions (design conditions) not approved for this product.
  - Malfunction or damage caused by maintenance or inspection not recommended by MAYEKAWA.
  - Malfunction or damage caused by parts that are not **MYCOM** genuine.
  - Malfunction or damage caused by remodeling the product without approval of MAYEKAWA.
  - Malfunction or damage caused by unexpected misuse

"Liquid flow-back operation" is . . .

Normally, while the compressor sucks in the refrigerant liquid only after vaporizing it in the evaporator, it may directly suck it in because of the faulty adjustment or failure of the expansion valve. We call this state of compressor operation "liquid flow-back operation".

No compressor can compress a liquid. The compressor may be damaged should the liquid be sucked in.

## Important Information

### Intended Use of This Product

This product is a general-purpose screw compressor for refrigeration, cold storage and various gases compression. Do not use this product for any other purposes that are not intended for or which depart from the specifications. For specifications of this product, refer to "2.3 Compressor Specifications".

Please perform the maintenance items described in this manual by using safe and assured procedures.

### Important Information for Safe Use of This Product

Although MAYEKAWA has paid a lot of attention to safety measures for this product, all hazards including potential hazards caused by human errors, or due to environmental conditions can not be anticipated.

As there are too many items to be strictly observed or prohibited when using this product, it is impossible to inform all of them through this manual or warning labels. Therefore, when operating this product, pay extreme caution on personnel safety as well as on items described in this manual.

Important rules for safety work with this product that apply to all workers including managers and supervisors are listed below.

Please read this manual before using this product. Fully understand the instructions provided there, and be sure to perform the safety procedures described in this manual.

- Operation, maintenance, and inspection of this product should be performed by qualified personnel educated about the fundamentals of this product and trained about hazards involved and measures to avoid danger.
- Do not allow any person other than those educated on the fundamental expertise of this product and trained about hazards involved and measures to avoid dangers to approach this product while it is operating or during maintenance.
- Observe all related federal/national and local codes and regulations.
- To prevent accidents, do not carry out any operation or maintenance other than those described in this manual. Do not use this product for any purpose other than intended.
- Replace the parts with **MYCOM** genuine parts.
- Not only workers but also managers should actively participate safety and health activities in the workplace to prevent accidents.
- When closing or opening a valve during work, make sure to apply lockout/tagout to prevent the valve from being accidentally closed or opened during the work.

#### **[Lockout] To lock with a key in order to keep people, except the workers involved, from operating the product.**

Lockout means disconnecting or keeping disconnected machines and devices by locking their energy (power) sources. Lockout is not just simply turning off the power switches to stop the supply of power, but includes immobilizing them with a key or similar device to keep any blocked switches from being operated.

Lockout devices are devices such as keys, covers, and latches, to immobilize switches, valves, opening and closing levers, etc., with a state of being locked.

#### **[Tagout] To prevent any inappropriate work by hanging tag plates indicating "work in progress".**

Tagout means to clearly indicate, by hanging tag plates, that a device is in lockout and that operation of the device is prohibited. Tag plates forbidding operation, starting, opening, etc. are warnings clearly stating to not operate energy (power) sources, and are not for stopping blocking devices.

Observe the following precautions when performing maintenance work on electrical control.

- Electrical maintenance of the product must be performed by certified/qualified personnel and only those educated about the electrical control of the product.
- Before servicing or inspecting the electrical equipment or devices, turn "OFF" the motor main power and control power, and perform lockout/tagout to prevent the power from being turned on during work.

Even when the motor main power and control power are turned "OFF", this product may be turned on if the power is supplied from outside the package unit in which this product is used. Make sure the power supply on the power source side is shut off, and perform lockout/tagout to prevent this product from being turned on during work.

## About This Manual

- This product may be modified without prior notice. Therefore, the appearance of actual machine may differ from the descriptions in this manual. If you have any questions, contact our sales offices or service centers. For each sight of MAYEKAWA, refer to "Contact Information" in this manual or following URL. <http://www.mayekawa.com/about/network/>
- This manual is in English. If any other language is required, it is the customers responsibility to prepare a manual for safety education and operation instructions.
- This manual is copyrighted. Drawings and technical references including this manual shall not, in whole or part, be copied, photocopied, or reproduced into any electronic medium or machine-readable form without prior permission from MAYEKAWA.
- Photographs or drawings included in this manual may differ from the appearance of actual product.
- If this manual is lost or damaged, immediately request our local sales offices or service centers for a new manual. Using this product without the manual may result in safety issues.
- If you resell this product, never fail to attach this manual to this product.

## Construction of This Manual

Chapter/Section Title	Details
Preface	Describes the outline of this manual and how to use it.
Warranties and Disclaimer	Describes what MAYEKAWA warrants and what are covered by the warranties. Warranty exemption is stated as disclaimer.
Important Information	Describes important information related to this product and this manual.
1. Safety	Describes workers' safety information, safety measures taken for this product, and administrative control on industrial safety which is required when handling this product.
2. Compressor Specifications and Structure	Describes main components of this product and their functions, specifications and operating limits.
3. Installation	Describes procedures for installing this product.
4. Compressor and Package Unit Operation	Describes precautions for using this product.
5. Maintenance and Inspection	Describes inspection locations & frequency and assembly & disassembly of this product.
6. Troubleshooting	Regarding major troubles that may occur during use of this product, describes how this product will act as well as what actions should be taken when a trouble may occur.
7. Related Documents	Shows materials such as exploded drawings and parts list.
Contact Information	Provides contact information for our sales offices and service centers which is to be used for purposes such as <b>MYCOM</b> genuine parts ordering.

# Table of Contents

<b>Preface</b> .....	<b>i</b>
<b>Revision History</b> .....	<b>i</b>
<b>Warranty and Disclaimer</b> .....	<b>ii</b>
<b>Important Information</b> .....	<b>iii</b>
Intended Use of This Product .....	iii
Important Information for Safe Use of This Product .....	iii
About This Manual .....	iv
Construction of This Manual .....	iv
<b>Table of Contents</b> .....	<b>v</b>

## Chapter 1 Safety

<b>1.1 Strict Requirements and Prohibitions</b> .....	<b>1-1</b>
1.1.1 Strict Requirements (Do's).....	1-1
1.1.1.1 Do's on Operation.....	1-1
1.1.1.2 Do's on Maintenance.....	1-1
1.1.1.3 Do's on Lockout/Tagout after Shutting Off the Power .....	1-1
1.1.1.4 Do's about Personal Protective Gear .....	1-2
1.1.1.5 Do's about Handling of Hazardous and Toxic Substances.....	1-2
1.1.1.6 Do's about Handling Emergency Situations .....	1-2
1.1.1.7 Do's about Waste Oil, Fluid, and Materials .....	1-2
1.1.1.8 Other Do's.....	1-2
1.1.2 Prohibitions (Don'ts) .....	1-3
<b>1.2 Warnings</b> .....	<b>1-3</b>
<b>1.3 Residual Risks</b> .....	<b>1-4</b>
<b>1.4 Safety Devices</b> .....	<b>1-6</b>
1.4.1 Emergency Stop Button.....	1-6
1.4.2 Breakers of Motor Main Power and Control Power (with Lockout/Tagout Mechanism) .....	1-6
1.4.3 Compressor Protective Devices .....	1-7

## Chapter 2 Compressor Specifications and Structure

<b>2.1 Overview of the MYCOM 2016**C</b> .....	<b>2-1</b>
<b>2.2 Model Designation of the Compressor</b> .....	<b>2-1</b>
<b>2.3 Compressor Specifications</b> .....	<b>2-2</b>
2.3.1 Standard Specifications .....	2-2
2.3.2 Operation Limits.....	2-4
2.3.3 Outer Dimensions .....	2-4
<b>2.4 Structure of Compressor</b> .....	<b>2-10</b>
2.4.1 Sectional View .....	2-10

<b>2.5 Mechanisms .....</b>	<b>2-11</b>
2.5.1 Basics of the Screw Compressor .....	2-11
2.5.2 Suction Process.....	2-11
2.5.3 Compression Process.....	2-12
2.5.4 Discharge Process.....	2-12
2.5.5 About Volume Ratio (Vi) .....	2-12
2.5.6 Capacity Control Mechanism.....	2-14
2.5.7 Bearings and Balance Piston .....	2-14
2.5.8 Shaft Seal .....	2-14
<b>2.6 Gas and Oil Flow.....</b>	<b>2-15</b>

## **Chapter 3 Installation**

<b>3.1 General Precautions for Installation .....</b>	<b>3-1</b>
<b>3.2 Installation Works .....</b>	<b>3-1</b>
3.2.1 Unpacking.....	3-1
3.2.2 Storage .....	3-1
3.2.3 Transportation.....	3-1
3.2.4 Preparation for Installation.....	3-4
3.2.5 Installation.....	3-5
3.2.5.1 Installation.....	3-5
3.2.5.2 Shaft Alignment between the Compressor and Driving Machine .....	3-5
3.2.5.3 Piping Connection .....	3-6
3.2.5.4 Equipment and Devices for Protection of the Compressor .....	3-6
3.2.6 Airtightness Test.....	3-7
3.2.7 Lubricating Oil Charge .....	3-7
3.2.7.1 Initial Charge of Lubricating Oil .....	3-7
3.2.7.2 Additional Charge of Lubricating Oil.....	3-7
3.2.8 Charge of Refrigerant .....	3-7
3.2.9 Check after Installation .....	3-7

## **Chapter 4 Compressor and Package Unit Operation**

<b>4.1 Lubricating Oil (Refrigerant Oil) .....</b>	<b>4-1</b>
4.1.1 Precautions for Selecting the Lubricating Oil.....	4-1
4.1.2 Recommended Lubricating Oils .....	4-1
4.1.2.1 Recommended Lubricating Oils for Ammonia Refrigerant.....	4-1
4.1.2.2 Oils for systems using Hydrofluorocarbon (HFC) refrigerants .....	4-2
4.1.3 Change of Lubricating Oil Brand .....	4-3
4.1.4 Precautions for Handling lubricating Oil .....	4-4
4.1.4.1 Precautions for Handling Polyalkylene Glycol (PAG).....	4-4
4.1.4.2 Precautions for Handling Polyolester (POE) Oil.....	4-4
4.1.5 Lubricating Oil Management Criteria .....	4-5
4.1.6 Lubricating Oil Replacement Timing.....	4-6

4.1.6.1	After Starting the Initial Operation .....	4-6
4.1.6.2	During Normal Operation.....	4-6
<b>4.2</b>	<b>Precautions for Operation.....</b>	<b>4-7</b>
4.2.1	Prevention of Liquid Flow-back Operation.....	4-7
4.2.2	Purging of Non-Condensable Gases.....	4-7
<b>4.3</b>	<b>When Stopping the Compressor for a Long Time .....</b>	<b>4-8</b>

## Chapter 5 Maintenance and Inspection

<b>5.1</b>	<b>Precautions for Maintenance and Inspection.....</b>	<b>5-1</b>
<b>5.2</b>	<b>Maintenance and Inspection List.....</b>	<b>5-3</b>
5.2.1	Daily Management.....	5-3
5.2.2	Periodic Inspection .....	5-5
5.2.3	Guidelines for the Timing of Compressor Overhaul .....	5-6
<b>5.3</b>	<b>Compressor Disassembly Preparation .....</b>	<b>5-7</b>
5.3.1	Disassembly Tools and Workplace .....	5-7
5.3.2	Replacement Parts .....	5-7
5.3.3	Refrigerant Gas Recovery .....	5-10
5.3.4	Removal of Connections to the Unit.....	5-11
5.3.5	Removal and Lifting the Compressor .....	5-12
5.3.6	Draining Oil from the Compressor .....	5-12
<b>5.4</b>	<b>Disassembly and Inspection.....</b>	<b>5-13</b>
5.4.1	Shaft Seal Block .....	5-15
5.4.1.1	Disassembly .....	5-15
5.4.1.2	Inspection .....	5-16
5.4.2	Unloader Indicator .....	5-18
5.4.2.1	Disassembly .....	5-18
5.4.2.2	Inspection .....	5-20
5.4.3	Unloader Cover.....	5-21
5.4.3.1	Disassembly .....	5-21
5.4.3.2	Inspection .....	5-22
5.4.4	Unloader Piston and Unloader Cylinder .....	5-22
5.4.4.1	Disassembly .....	5-22
5.4.4.2	Inspection .....	5-23
5.4.5	Bearing Cover.....	5-24
5.4.5.1	Disassembly .....	5-24
5.4.6	Separating High-stage and Low-stage .....	5-25
5.4.6.1	Disassembly .....	5-25
5.4.7	Gear Coupling.....	5-25
5.4.7.1	Disassembly .....	5-26
5.4.7.2	Inspection .....	5-26
5.4.8	Balance Piston Cover .....	5-27
5.4.9	Balance Piston.....	5-27
5.4.9.1	Disassembly .....	5-27



5.4.9.2	Inspection .....	5-28
5.4.10	High-stage Suction Cover and Side Bearings .....	5-29
5.4.10.1	Disassembly .....	5-29
5.4.10.2	Inspection .....	5-30
5.4.11	Low-stage Suction Cover and Side Bearings .....	5-31
5.4.11.1	Disassembly .....	5-31
5.4.11.2	Inspection .....	5-31
5.4.12	Thrust Bearing Block .....	5-32
5.4.12.1	Disassembly of the High-stage Thrust Bearing Block .....	5-32
5.4.12.2	Disassembly of the Low-stage Thrust Bearing Block .....	5-33
5.4.12.3	Inspection (High-stage and Low-stage) .....	5-33
5.4.13	High-stage Rotors and Main Rotor Casing .....	5-35
5.4.13.1	Disassembly .....	5-35
5.4.13.2	Inspection .....	5-35
5.4.14	Low-stage Rotors and Main Rotor Casing .....	5-36
5.4.15	High-stage Bearing Head and Main Bearings .....	5-37
5.4.15.1	Disassembly .....	5-37
5.4.16	Low-stage Bearing Head and Main Bearings .....	5-38
<b>5.5</b>	<b>Reassembly .....</b>	<b>5-39</b>
5.5.1	Unloader Slide Valve and Guide Block .....	5-41
5.5.2	Bearing Head and Main Bearings .....	5-42
5.5.3	Bearing Head and Main Rotor Casing .....	5-43
5.5.4	Installing Rotors .....	5-44
5.5.5	Suction Cover and Side Bearings .....	5-45
5.5.6	Balance Piston Sleeve .....	5-46
5.5.7	Installing Suction Cover .....	5-47
5.5.8	Thrust Bearing Block .....	5-49
5.5.8.1	End Clearance Measurement .....	5-51
5.5.8.2	Procedure for End Clearance Adjustment .....	5-53
5.5.8.3	Tightening after Finishing the End Clearance Adjustment .....	5-52
5.5.9	Bearing Cover .....	5-54
5.5.10	Coupling High-stage and Low-stage Blocks .....	5-55
5.5.11	Balance Piston Cover and High-stage Unloader Cylinder .....	5-57
5.5.12	Low-stage Unloader Cylinder .....	5-59
5.5.13	Shaft Seal Block .....	5-61
5.5.13	Unloader Cover .....	5-64
5.5.15	Unloader Indicator .....	5-65
5.5.15.1	Potentiometer .....	5-65
5.5.15.2	Micro-switches and Micro-switch Cam .....	5-66
5.5.15.3	Reassembly .....	5-66

## Chapter 6 Troubleshooting

01: Compressor does not start up .....	6-1
02: Compressor stops immediately after startup.....	6-1
03: Unusually low pressure (decrease of suction pressure) .....	6-2
04: Low oil pressure (low lubricating oil supply pressure).....	6-2
05: Intermediate pressure is unusually high.....	6-3
06: Unusually high pressure (abnormal discharge pressure) .....	6-4
07: Discharge temperature is abnormally high.....	6-5
08: Leak from mechanical seal.....	6-6
09: Squeaking of mechanical seal.....	6-7
10: Capacity control position is indicated incorrectly.....	6-7
11: Capacity control malfunction .....	6-8
12: Compressor generates abnormal vibration and/or sound.....	6-9

## Chapter 7 Related Documents

<b>7.1 Development Views, Assembly Sectional Views .....</b>	<b>7-1</b>
<b>7.2 Parts Configuration Table .....</b>	<b>7-13</b>
<b>7.3 Tightening Torques for Bolts and Nuts .....</b>	<b>7-20</b>
<b>7.4 About the O-rings Used.....</b>	<b>7-22</b>
7.4.1 List of O-rings Used .....	7-22
7.4.2 O-ring Materials Used for Screw Compressor.....	7-22
<b>7.5 Tools for Disassembly.....</b>	<b>7-23</b>

## Contact Information

Sales Offices in Japan .....	Contact-1
Manufacturing Bases in Japan.....	Contact-1
Global Network.....	Contact-2
NORTH AMERICA .....	Contact-2
EUROPE and AFRICA.....	Contact-2
ASIA PACIFIC .....	Contact-3
LATIN AMERICA.....	Contact-5

# Chapter 1 Safety

## 1.1 Strict Requirements and Prohibitions

### 1.1.1 Strict Requirements (Do's)

#### 1.1.1.1 Do's on Operation

- Make sure to install safety and protective devices on the package unit.
- Regularly inspect the safety and protective devices if they function properly.
- If the safety or protective devices do not work properly or if this product operates abnormally, immediately stop the operation and report to the supervisor. Obtain his/her approval and direction before restarting this product.
- If this product stops for unknown reasons, immediately inform your supervisor of it. Obtain his/her approval before restarting the compressor.
- Some types of refrigerants emit bad smell or toxic gases when they leak. Make sure to ventilate the air during operation.
- For the properties of refrigerant and lubricating oil (corrosiveness, decomposability or toxicity), be sure to obtain the Safety Data Sheet (SDS) and follow the relevant information.
- When stopping the operation of this product, close the suction and discharge side shut-off valves and turn "OFF" the motor (main power), heater power, and control power.

#### 1.1.1.2 Do's on Maintenance

- Prepare work procedures based on a work schedule. Be sure to perform danger forecasting before starting the work.
- Before performing the work together with at least one other person, thoroughly confirm each other's work details and procedures to acknowledge the other worker's movement.
- When troubleshooting during operation or before performing setup, cleaning, maintenance, or inspection of this product, always turn OFF the main power to the motor and control power and other devices. Also, lock and tag out them to prevent the power from being supplied erroneously during operation.
- When troubleshooting during operation or before performing setup, cleaning, maintenance, or inspection of this product, confirm that the pressure inside this product and the package unit is at atmospheric pressure.
- Some refrigerants in use generate bad smell or toxic gases, or may cause deficiency of oxygen. Before starting work, measure oxygen concentration in the work area as necessary. Ventilate the area well. Be sure to keep the area well ventilated until the work is finished.
- For the properties of refrigerant and lubricating oil (corrosiveness, decomposability or toxicity), be sure to obtain the Safety Data Sheet (SDS) and follow the relevant information.
- After using tools always restore to designated place and never leave tools in the package unit.

#### 1.1.1.3 Do's on Lockout/Tagout after Shutting Off the Power

- Attach lockout/tagout mechanism to the main breakers of motor main power and control power. Lockout/tagout after power off is a very effective means to secure safety. It can prevent the power source from being turned on by accident by two or more workers which may cause injury to other worker(s).

- If there are any possibilities of danger during works (especially during cleaning, maintenance and inspection, and troubleshooting), turn "OFF" the motor main power and control power, and perform lockout/tagout.
- In the following situations, workers may neglect to perform power source shutoff or lockout/tagout. Clearly notify the workers of the necessity of lockout/tagout.
  - It is assumed that workers do not perform lockout/tagout before starting work because it is troublesome, and only turn "OFF" the main motor and control power.
  - It is assumed that workers only turn off the main motor and control power and do not lockout/tagout the main motor and control power, because they judge that there is no danger.

#### **1.1.1.4 Do's about Personal Protective Gear**

- Prepare and use protective gear complying with the safety standards of the regulations.
- Check the function of each protective gear before using.
- Wear designated clothes such as work outfits, with their cuffs tightly closed.
- Do not wear any neckties or jewelry as there is a risk of being entangled by a movable part or rotating part. Put on a helmet as your hair may get entangled.
- Do not have anything in your pocket to prevent objects from falling into the package unit..

#### **1.1.1.5 Do's about Handling of Hazardous and Toxic Substances**

- Obtain the Safety Data Sheet (SDS) from manufacturers of hazardous and toxic substances. Check the SDS and follow the handling instructions recommended by the manufacturers to handle and store those substances.

#### **1.1.1.6 Do's about Handling Emergency Situations**

- Formulate an emergency action plan complying with the regulations, and post it on a safe place.

#### **1.1.1.7 Do's about Waste Oil, Fluid, and Materials**

- Disposing of refrigerant and oil used for this product are subject to a number of regulations for the environmental protection purposes. Follow the local, state, federal acts and regulations and your company's rules when disposing of such waste oil, fluid and materials.

#### **1.1.1.8 Other Do's**

- Clean the floor around the entire package unit. Provide a safety passage.
- Walk only on the areas set up as a work floor. Also, do not leave tools and cleaning solutions in that area.
- If water or oil is spilled on this product or the floor, immediately wipe it off to prevent workers from slipping and getting injured.

### 1.1.2 Prohibitions (Don'ts)

- Do not remove or relocate any safety device, including electrical interfaces.
- Do not disable any safety device by short-circuiting or bypassing without any permission.
- Do not leave this product unsafe and unattended, by removing a safety cover or some other measures.
- Do not touch, clean or lubricate any part of this product which is moving.
- Do not touch relays or electric systems such as terminal block with bare hands when turning on the power.



## 1.2 Warnings

The warning messages described in this manual warn dangerous situations that may arise during work by using the following four categories.

Neglecting such warnings may cause accidents, resulting in personal injury or even death.

Also, this product or its auxiliary equipment may be heavily damaged. Therefore, be sure to always observe the instructions of the warnings.

**Table 1-1 Warning Symbols and their Meanings**

Symbol	Meaning
 <b>DANGER</b>	Indicates a hazardous situation which, if not avoided, could very likely cause serious injury or death.
 <b>WARNING</b>	Indicates a potentially hazardous situation which, if not avoided, may cause serious injury or death.
 <b>CAUTION</b>	Indicates a potentially hazardous situation which, if not avoided, may cause minor or moderate injury.
<b>CAUTION</b>	Indicates a potentially hazardous situation which, if not avoided, may result in property damage.

## 1.3 Residual Risks

The following information assumes that this product is operated or inspected/maintained while being used in general refrigerating/cold storage/gas compression package units.

Note that all hazardous sources cannot be predicted for the applications mentioned.

Devise appropriate countermeasures for hazardous sources in your systems.

**Table 1-2 Hazardous Sources**

	<b>Hazardous sources</b>	<b>Predicted hazard</b>	<b>Countermeasures in operation</b>	<b>Countermeasures in cleaning, inspection, and parts exchange</b>
A	Motor and compressor coupling Refer to Figure 1-1	<ul style="list-style-type: none"> <li>Caught in due to contact</li> </ul>	<ul style="list-style-type: none"> <li>Install coupling cover and prohibit opening.</li> <li>Keep away.</li> </ul>	<ul style="list-style-type: none"> <li>Turn off motor main power and control power, and conduct lockout/tagout.</li> </ul>
B	Motor terminals	<ul style="list-style-type: none"> <li>Electric shock caused by contact with live wires or electrical leakage</li> </ul>	<ul style="list-style-type: none"> <li>Keep away.</li> <li>Do not open terminal boxes.</li> <li>Do not touch terminal boxes.</li> </ul>	<ul style="list-style-type: none"> <li>Turn off motor main power and control power, and conduct lockout/tagout.</li> </ul>
C	Compressor low-stage side suction casing Refer to Figure 1-1	<ul style="list-style-type: none"> <li>Frostbite due to contact</li> <li>Contact with or inhalation of hazardous substances generated by leakage of refrigerant or the like</li> </ul>	<ul style="list-style-type: none"> <li>Keep away and do not touch.</li> <li>Wear protective gear.</li> <li>Detect gas leakage.</li> </ul>	<ul style="list-style-type: none"> <li>Wear protective gear.</li> <li>Work under room temperature.</li> </ul>
D	Compressor intermediate piping (low-stage discharge port to high stage suction port) Refer to Figure 1-1	<ul style="list-style-type: none"> <li>Burn injury due to contact</li> <li>Contact with or inhalation of hazardous substances generated by leakage or spout of refrigerant or the like</li> </ul>	<ul style="list-style-type: none"> <li>Keep away and do not touch</li> <li>Wear protective gear</li> <li>Gas leakage detection</li> </ul>	<ul style="list-style-type: none"> <li>Wear protective gear</li> <li>Work in temperatures below 40 °C</li> </ul>
E	Compressor high-stage side discharge casing and discharge piping Refer to Figure 1-1	<ul style="list-style-type: none"> <li>Burn injury due to contact</li> <li>Contact with or inhalation of hazardous substances generated by leakage or spout of refrigerant or the like</li> </ul>	<ul style="list-style-type: none"> <li>Keep away and do not touch.</li> <li>Wear protective gear.</li> <li>Detect gas leakage.</li> </ul>	<ul style="list-style-type: none"> <li>Wear protective gear.</li> <li>Work at a temperature of not higher than 40°C.</li> </ul>
F	Check valves/service valves and joints on each section of the package unit	<ul style="list-style-type: none"> <li>Contact with or inhalation of hazardous substances generated by mishandling or leakage</li> <li>Frostbite or burn due to contact</li> </ul>	<ul style="list-style-type: none"> <li>Sufficient ventilation</li> <li>Indicate valve open/close state.</li> <li>Keep away and do not touch.</li> <li>Wear protective gear.</li> </ul>	<ul style="list-style-type: none"> <li>Sufficient ventilation</li> <li>Wear protective gear.</li> <li>Tagout for controlled valve</li> </ul>
G	Solenoid valves/motor operated valves on each section of the package unit	<ul style="list-style-type: none"> <li>Electric shock caused by contact with live wires or electrical leakage</li> <li>Pinched due to contact with driving part</li> </ul>	<ul style="list-style-type: none"> <li>Install protective cover on terminals, and prohibit opening.</li> <li>Keep away and do not touch.</li> <li>Wear protective gear.</li> </ul>	<ul style="list-style-type: none"> <li>Turn off each breaker and the control power, and conduct lockout/tagout.</li> <li>Wear protective gear.</li> </ul>
H	Electric components in each section of the package unit (oil heater, protective switch, etc.)	<ul style="list-style-type: none"> <li>Electric shock caused by contact with live wires or electrical leakage</li> <li>Pinched due to contact with driving part</li> </ul>	<ul style="list-style-type: none"> <li>Install protective cover on terminals, and prohibit opening.</li> <li>Keep away and do not touch.</li> <li>Wear protective gear.</li> </ul>	<ul style="list-style-type: none"> <li>Turn off each breaker and the control power, and conduct lockout/tagout.</li> <li>Wear protective gear.</li> </ul>
I	Package unit oil drains	<ul style="list-style-type: none"> <li>Contact with hazardous substances generated by leakage or spout</li> <li>Burn caused by contact with high-temperature fluid</li> </ul>	<ul style="list-style-type: none"> <li>Sufficient ventilation</li> <li>Keep away and do not touch.</li> <li>Wear protective gear.</li> </ul>	<ul style="list-style-type: none"> <li>Sufficient ventilation</li> <li>Wear protective gear.</li> <li>Work at a temperature of not higher than 40°C.</li> </ul>
J	Noises	<ul style="list-style-type: none"> <li>Damage caused by noise</li> </ul>	<ul style="list-style-type: none"> <li>Wear protective gear.</li> </ul>	—

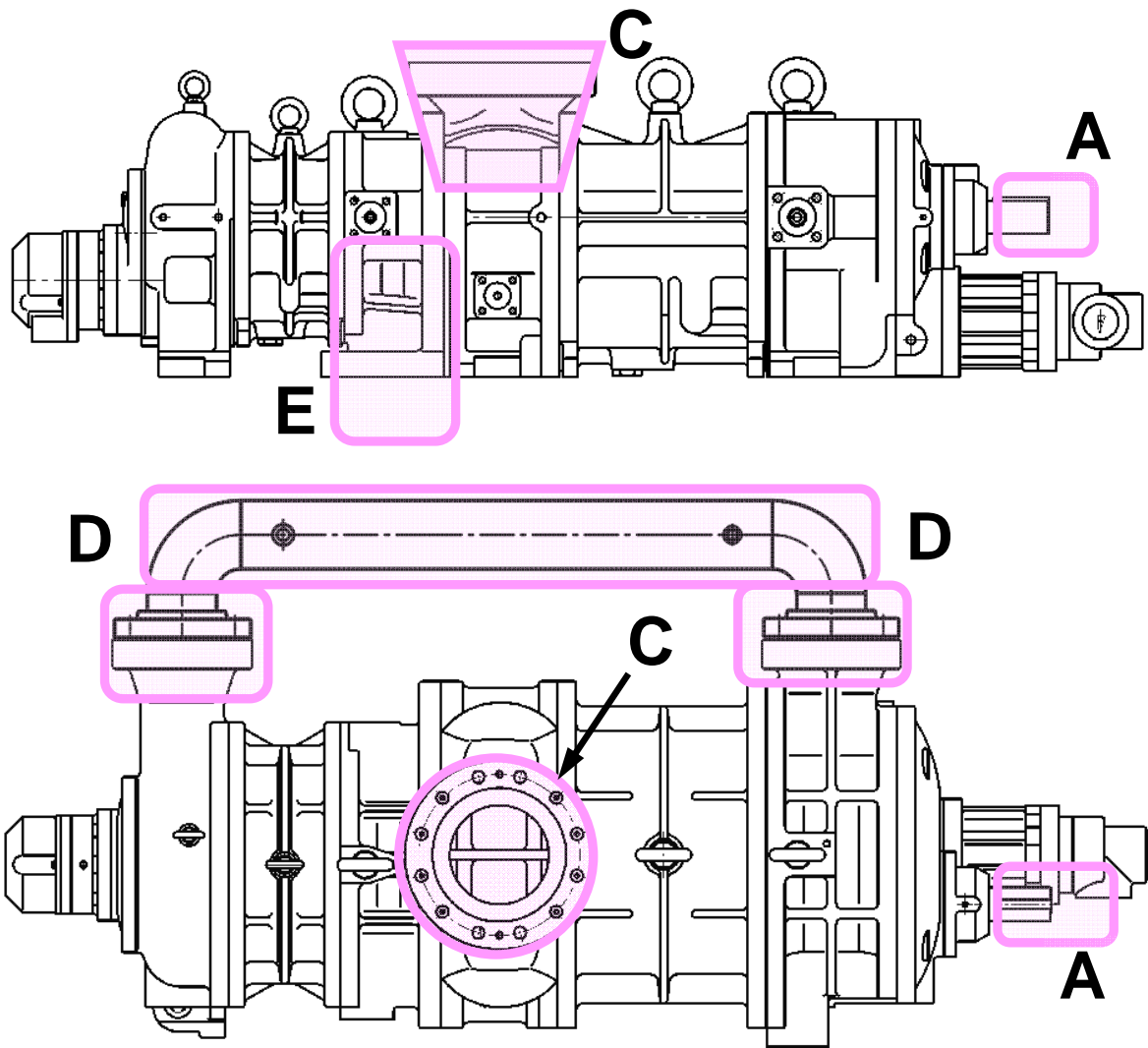

Figure 1-1 Locations of Hazardous Sources (compressor)

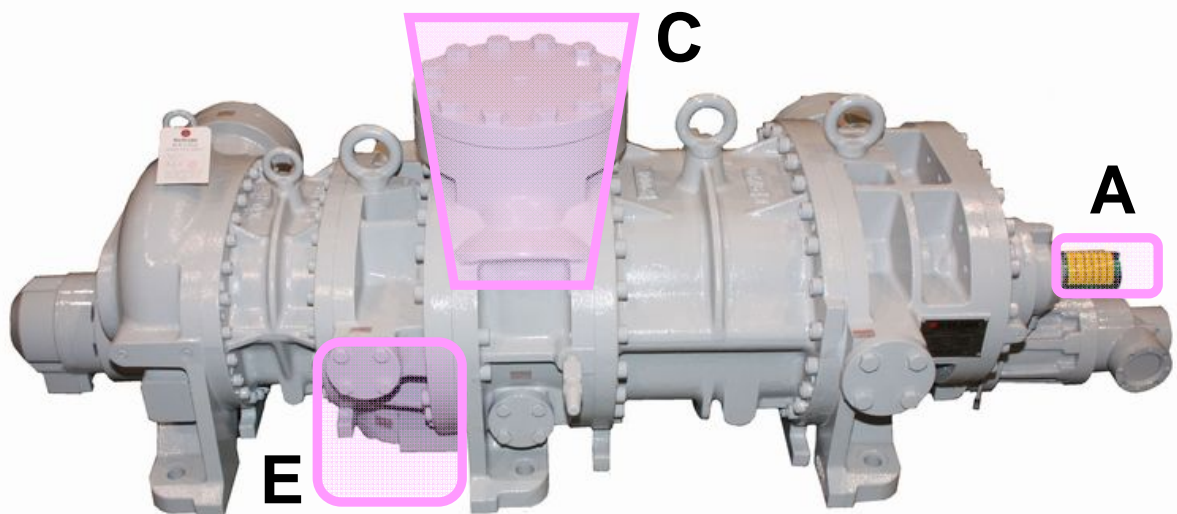

Photo 001 Locations of Hazardous Sources (Compressor)

## 1.4 Safety Devices

For safe use and protection of this product, make sure to attach safety devices to this product in accordance with the regulations and the following instructions.

Safety devices cannot be kept in normal condition unless inspected and maintained at regular intervals. Their maintenance and inspection need to be performed as an important part of the maintenance/inspection work project. Provide users of this product with necessary information on the safety devices, for example, types of the safety devices, installation position, function, and inspection method of safety related devices.



- **Check the safety devices after turning on the power and before operation of the compressor. If they do not operate normally, immediately take repair or replace safeties before starting compressor.**

### 1.4.1 Emergency Stop Button

#### ■ Overview/Function/Purpose

The emergency stop buttons are used to stop the compressor operation immediately if an emergency occurs in this product.

#### ■ Installation Positions

On the control board and in the operation control room

#### ■ Stop/Restoration Methods

The operating procedures for the emergency stop button, i.e., how to stop the operation and restore the normal operating condition, must be clearly defined and the information provided to the user of this product.

#### ■ Inspection Method/Cycle

The emergency stop buttons must be tested before commissioning and must also be periodically re-tested after that. The inspection procedures and the inspection interval for the emergency stop button must be clearly defined and the information provided to the user of this product.

### 1.4.2 Breakers of Motor Main Power and Control Power (with Lockout/Tagout Mechanism)

#### ■ Overview/Function/Purpose

Turn off the main motor and control power, and if there is any possibility of danger during work (especially during cleaning, maintenance, inspection, or troubleshooting), lockout/tagout devices must be used on the breakers of the main motor and control powers to prevent injuries to workers in case the power is turned on accidentally during work.

#### ■ Methods of Performing and Releasing Lockout/Tagout

Make sure to clearly notify methods of performing and releasing lockout/tagout referring to the regulations created by Occupational Safety & Health Administration (OSHA) or local governing body.

#### ■ Inspection Method/Cycle

The inspection procedures and the inspection interval for the lockout/tagout devices, must be clearly defined and the information provided to the user of this product.



### 1.4.3 Compressor Protective Devices



- **Be sure to adjust the set values and check operation of the protective devices at the commissioning.**

#### ■ Overview/Function/Purpose

These protective devices are used to protect this product.

- **Protecting from discharge temperature rise (DT)**

This device stops the compressor operation when the discharge temperature of the compressor exceeds the set value.

Install a temperature sensing port to the discharge pipe.

- **Protecting from oil temperature rise (OT)**

This device stops the compressor operation when the oil temperature of the compressor exceeds the set value.

Install a temperature sensing port to the package unit's oil supply pipe (after the oil cooler).

- **Protecting from high pressure (HP)**

This device stops the compressor operation when the discharge pressure abnormally rises due to mishandling of the compressor or stoppage of cooling water supply to the condenser.

This device prevents explosion of the equipment and components.

Install a pressure sensing port to the discharge pipe.

- **Protecting from intermediate pressure (IP)**

This device controls the compressor appropriately when the intermediate pressure exceeds the set value. In some cases, this device stops the compressor operation.

Install a pressure output port to the package unit's intermediate gas pipe (or compressor's intermediate gas pressure output port).

- **Protecting from suction pressure drop (LP)**

This device stops the compressor operation when the suction pressure becomes below the set value.

Install a pressure sensing port to the suction pipe.

- **Protecting from oil pressure (OP)**

This device stops the compressor operation when lubricating oil supply is not sufficient, the oil filter is clogged, the refrigerant is mixed into the lubricating oil, and oil supply pressure difference (from discharge pressure) becomes below the set value.

This device is to protect the compressor from wear and burnout.

Install a pressure sensing port to the package unit's oil supply pipe (after the oil pump) and the discharge pipe.

- **Protecting from motor overcurrent (OCR)**

This device controls the compressor appropriately when the current exceeds the set value. In some cases, this device stops the compressor operation.

This device is normally installed in the compressor operation controller.

### ■ Connection Positions and Settings

Specify the connection position and setting for each compressor protective device, and make sure to provide users of this product with them.

Make sure that the set values do not exceed the operating limits shown in Chapter 2, section 2.3.2 and Table 2-2 of this manual.

### ■ Inspection Method/Cycle

Compressor protective devices require operation tests and confirmation of the settings calibration before test run as well as at regular intervals.

Specify the inspection methods/intervals of the compressor protection devices, and make sure to provide users of this product with such information.

### CAUTION

- In the operation test, check that alarms and protective devices operate normally by using devices such as pressure tester. Do not operate the compressor with all the valves closed, or in any other dangerous conditions.
- If the protection from oil pressure (OP), high pressure (HP) activates, do not restart operation until the cause of activation is removed.

## Chapter 2 Compressor Specifications and Structure

### 2.1 Overview of the MYCOM 2016\*\*C

The 2016\*\*C model is the earliest model in the **MYCOM** compound 2-stage screw compressor C-series which started production in 1974 as well as 1612\*\*C model..

The 2-stage compression system, which has hitherto required two units of standard-type screw compressor for its embodiment, can now be realized by a single unit of compound 2-stage screw compressor.

Generally, screw compressors use oil injection to keep discharge temperature at a low level during operation without loss of volumetric efficiency even at high compression ratios. It can, therefore, be operated with a single-stage compression system even at evaporative temperatures near -40 °C.

However, for normal use at low temperatures, a 2-stage compression system is applied in order to improve kW/RT (ratio of power consumption versus cooling ability). If the 2-stage compression system is configured with standard-type screw compressors, at least two screw compressor units need to be installed, one on the high-stage and the other on the low-stage, which inevitably requires double installation of the entire system including machinery, motors, utilities, etc.

This 2-stage screw compressor is produced to solve this problem. It is a single unit that has two single-stage compressor units combined into one.

The 2016\*\*C model has a capacity control mechanism for startup load reduction on the high-stage, and a capacity control mechanism for coping with load change on the low-stage.

In addition, there are three specification types in rotor length for the low-stage and the high-stage each.

Moreover, customer is able to select each low-stage and high-stage volume ratio from two specifications. Employing these combinations of each specification, 2016\*\*C is providing a high versatility that can satisfy a wide range of operation conditions required by different applications at the load side.

### 2.2 Model Designation of the Compressor

This manual describes 2016\*\*C-\*B\*-51 and 2016\*\*C-\*B\*-61 models.

The meaning of the type designation, which is engraved on the MODEL column of the compressor nameplate, is as follows.

**\*2016\*\*C-\*B\*-51/61**

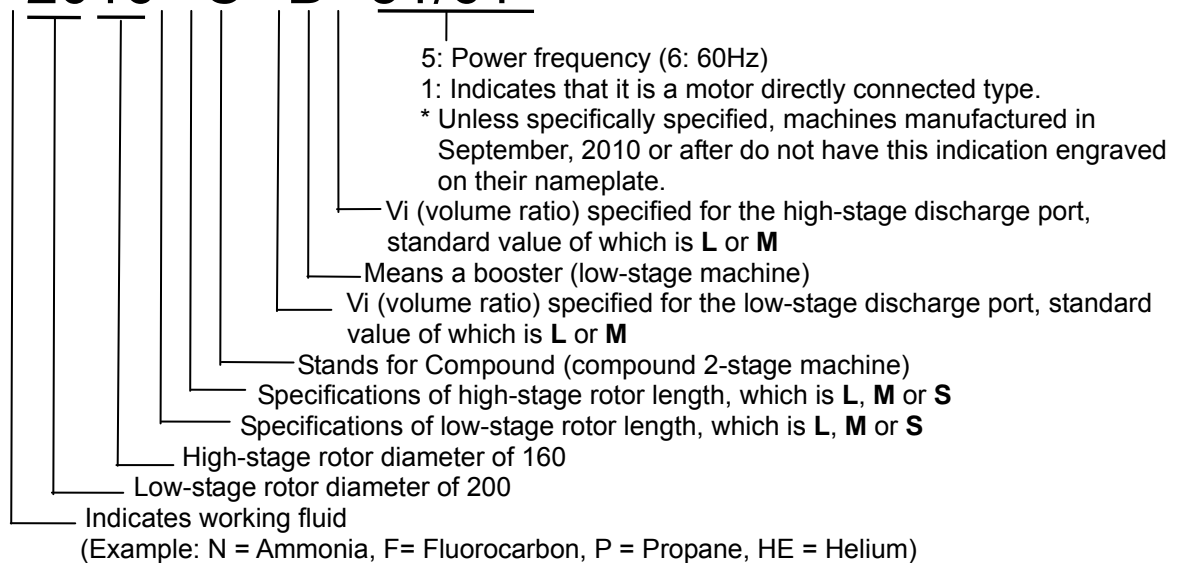

## 2.3 Compressor Specifications

### 2.3.1 Standard Specifications

Table 2-1 2016\*\*C Standard Specifications

Items		2016					
		LLC	LMC	LSC	MMC	MSC	SSC
Product mass	kg	1180	1140	1100	1090	1050	1000
Low-stage swept volume @3550 min <sup>-1</sup> /2950 min <sup>-1</sup>	m <sup>3</sup> /h	1460/1210	1460/1210	1460/1210	1220/1020	1220/1020	975/810
High-stage swept volume @3550 min <sup>-1</sup> /2950 min <sup>-1</sup>	m <sup>3</sup> /h	749/622	624/519	499/415	624/519	499/415	499/415
Refrigerant	-	Ammonia, Hydrofluorocarbon, etc.					
Design pressure	MPa	2.6					
Capacity control (Actual load)	%	10 to 100					
Rotation direction	-	Counterclockwise viewed from motor					
Connected pipe size	Low-stage suction flange	-	JIS 20K 150A (6")				
	Low-stage discharge flange	-	JIS 20K 100A (4")				
	High-stage suction flange	-	JIS 20K 100A (4")				
	High-stage discharge flange	-	JIS 20K 80A (3")				
	Journal lubrication (low-stage)	-	JIS 20K 25A (1")				
	Journal lubrication (high-stage)	-	JIS 20K 20A (3/4")				
	Oil injection lubrication	-	JIS 20K 15A (1/2")				
	Low-stage capacity control	-	Load: Rc1/4, Unload: Rc3/8				
	High-stage capacity control	-	Load: Rc3/8, Unload: Rc1/4				

- Unless otherwise noted, the pressure unit MPa represents the gauge pressure in this manual.
- For limits of working temperature and pressure, see "2.3.2 Operation Limits" in next Section

## 2.3.2 Operation Limits

Table 2-2 Operation Limits of 2016\*\*C

Items		Operation Limits
Maximum discharge pressure	MPa	1.96
Minimum suction pressure	MPa	-0.080
Maximum intermediate pressure	MPa	0.588
Minimum intermediate pressure	-	> Suction pressure
Oil supply pressure		
· Maximum journal lubrication pressure	MPa	Discharge pressure + 0.39
· Minimum journal lubrication pressure	MPa	Discharge pressure +0.049 and Suction pressure +0.49
· Minimum oil injection lubrication pressure	MPa	Suction pressure +0.49
Maximum Suction temperature	°C	85
Minimum suction temperature	°C	-60
Maximum low-stage discharge temperature	°C	90
Maximum high-stage discharge temperature	°C	100
Maximum oil supply temperature	°C	60
Minimum oil supply temperature	°C	30
Maximum male rotor rotation speed	min <sup>-1</sup>	3600
Minimum male rotor rotation speed	min <sup>-1</sup>	1450

Note : Unless otherwise noted, the pressure unit MPa represents the gauge pressure in this manual.

### CAUTION

- If operation at partial load, which is not greater than 30 % of the indicated load, is continued for a long time except when starting up the machine, abnormal noises or vibration may be generated. So avoid such operation.
- Repeated startup and stop in a short period is harmful not for the startup devices and electric machinery but also for the compressor itself. For information on the start/stop limitations, refer to each instruction manual. Wait at least 15 minutes after stopping the compressor before restarting it.

### 2.3.3 Outer Dimensions

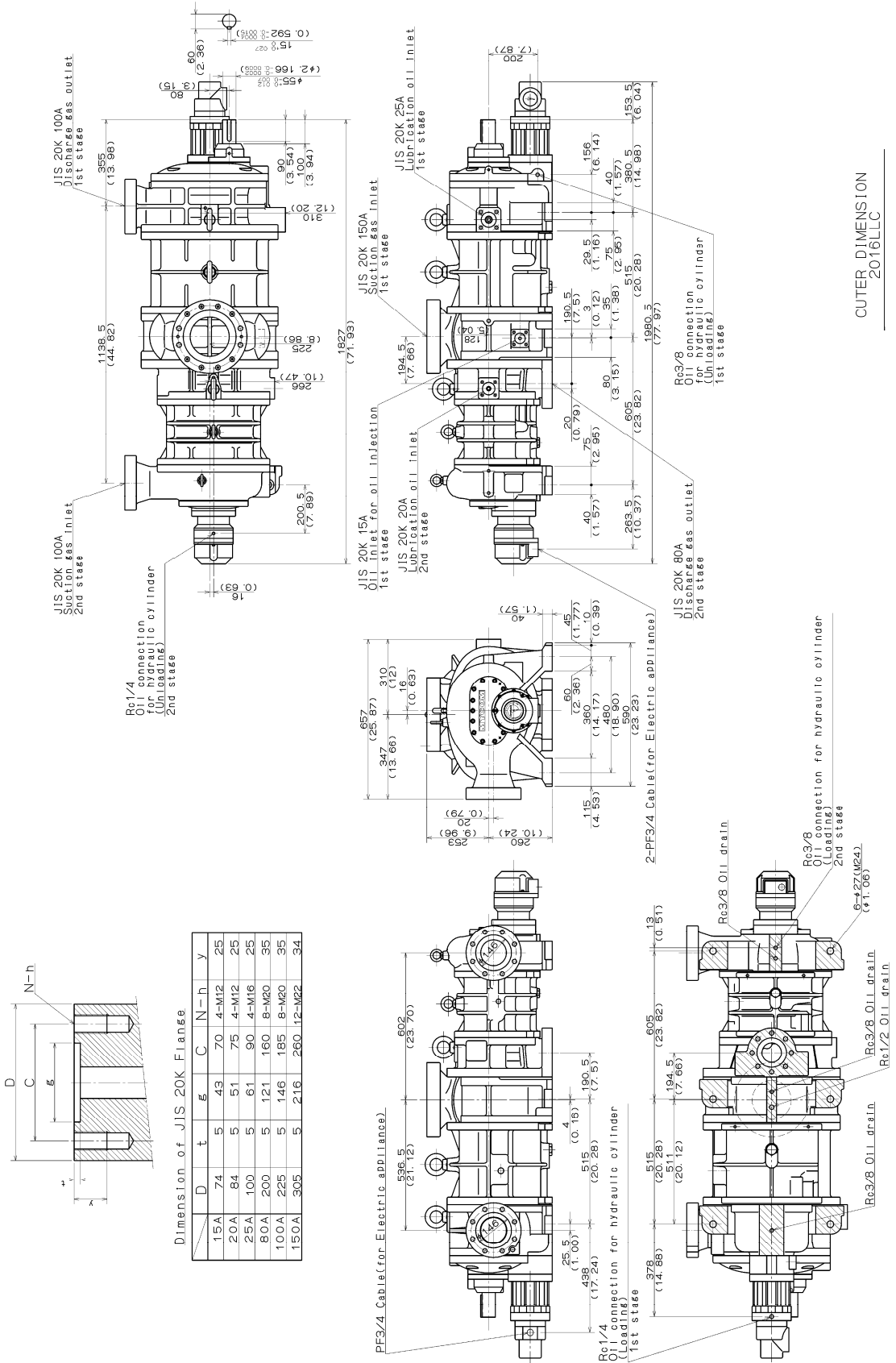

Figure 2-1 Outer Dimensions 2016LLC

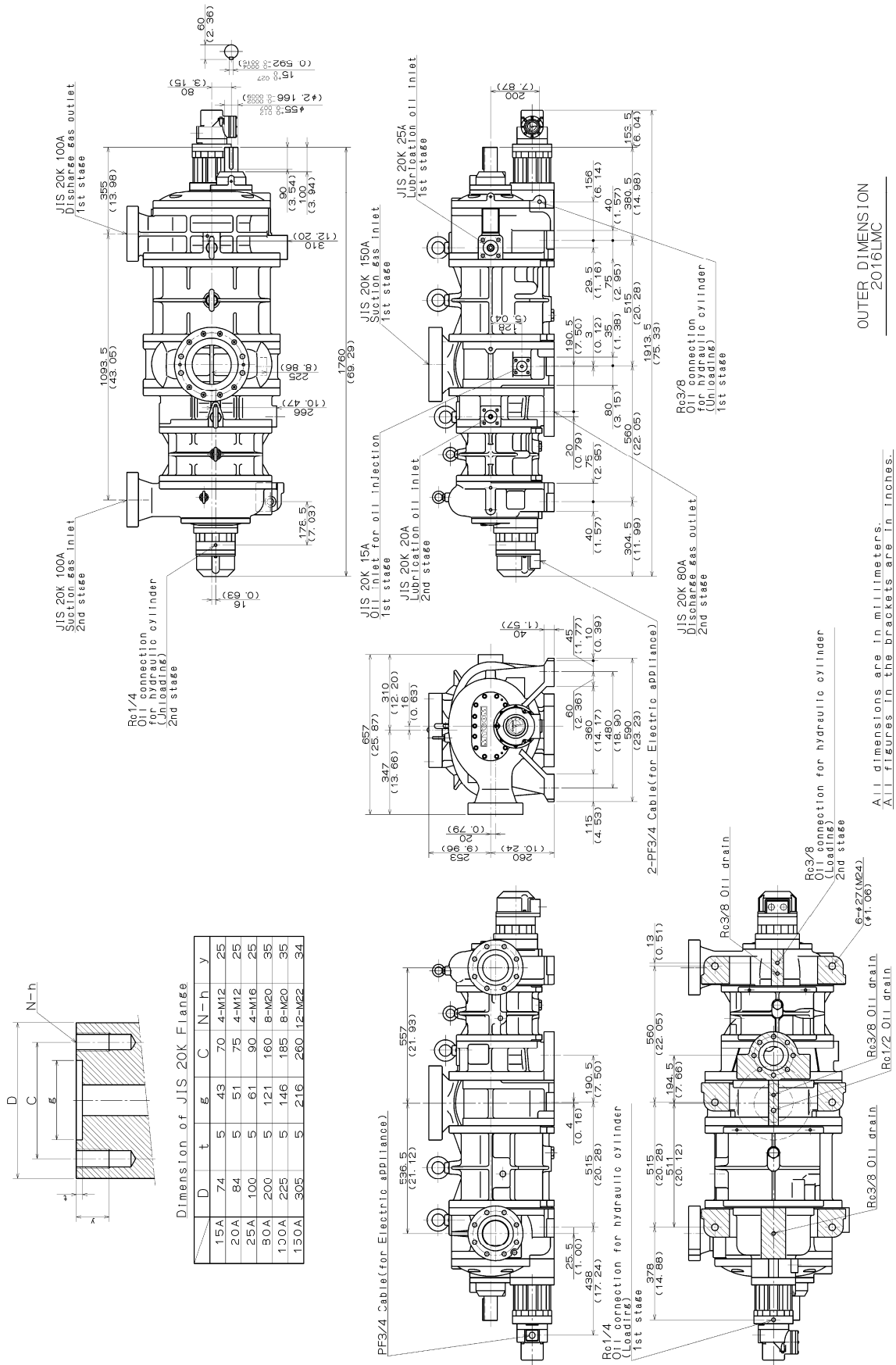

Figure 2-2 Outer Dimensions 2016LMC

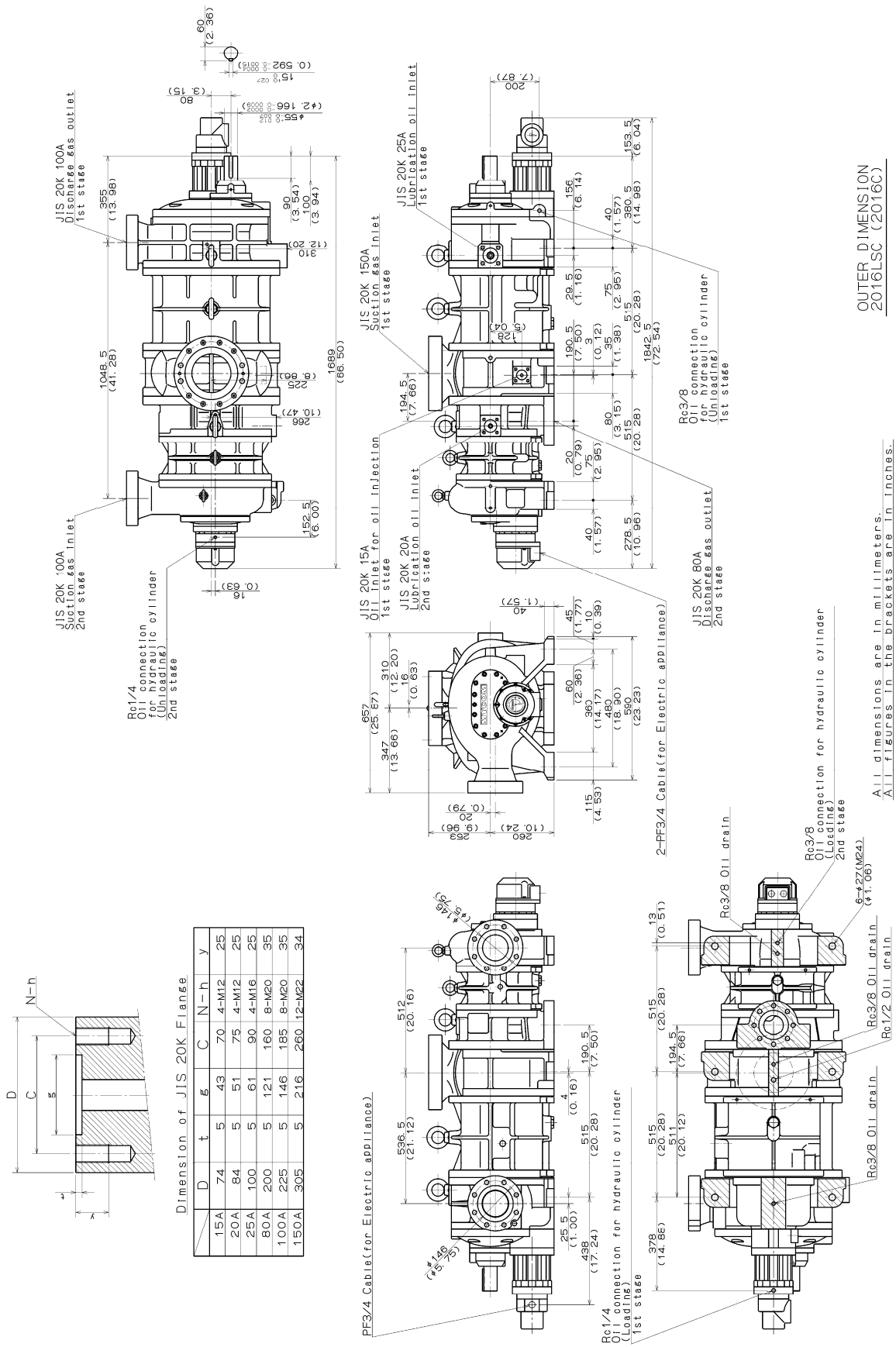

Figure 2-3 Outer Dimensions 2016LSC



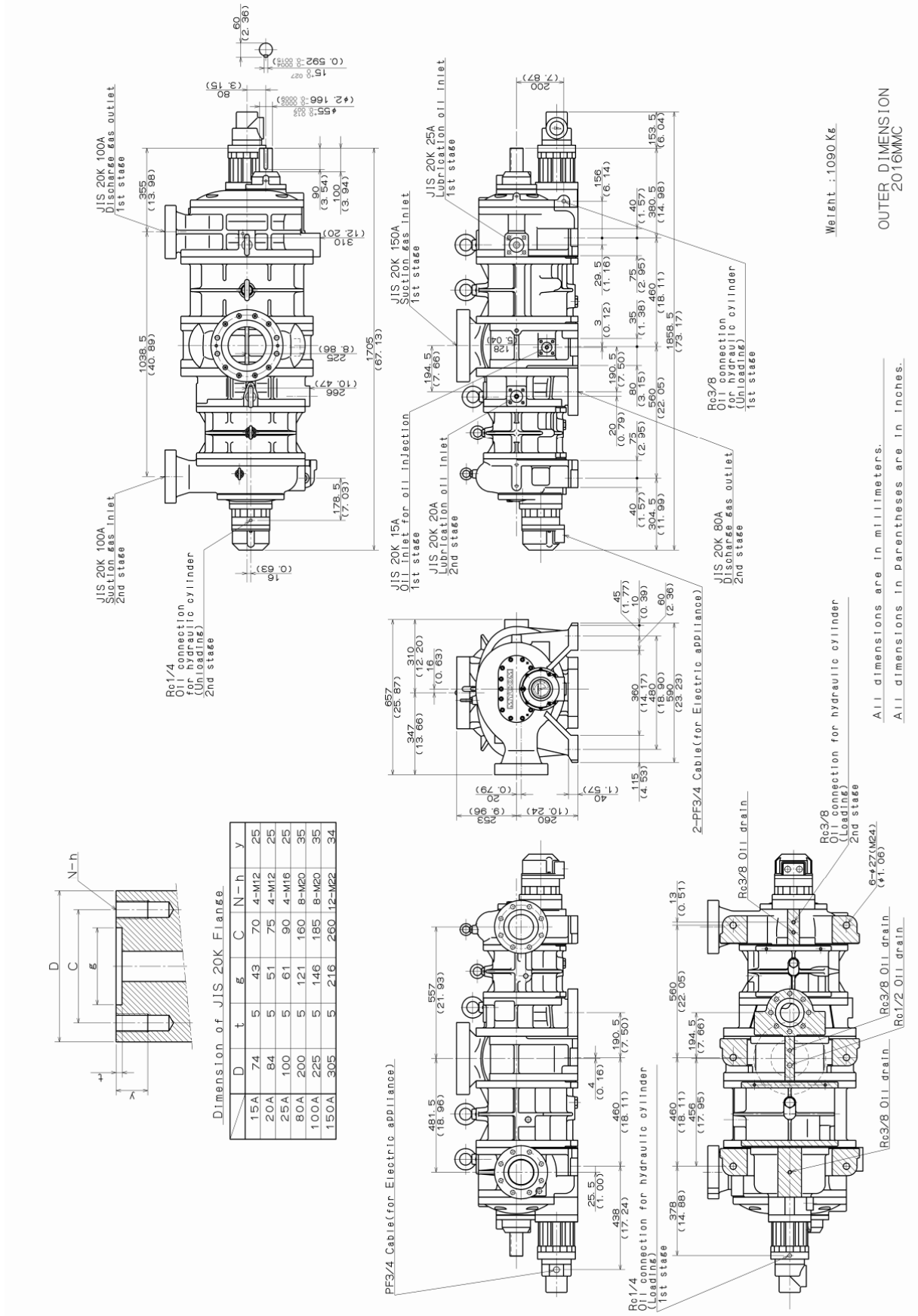

Figure 2-4 Outer Dimensions 2016MMC

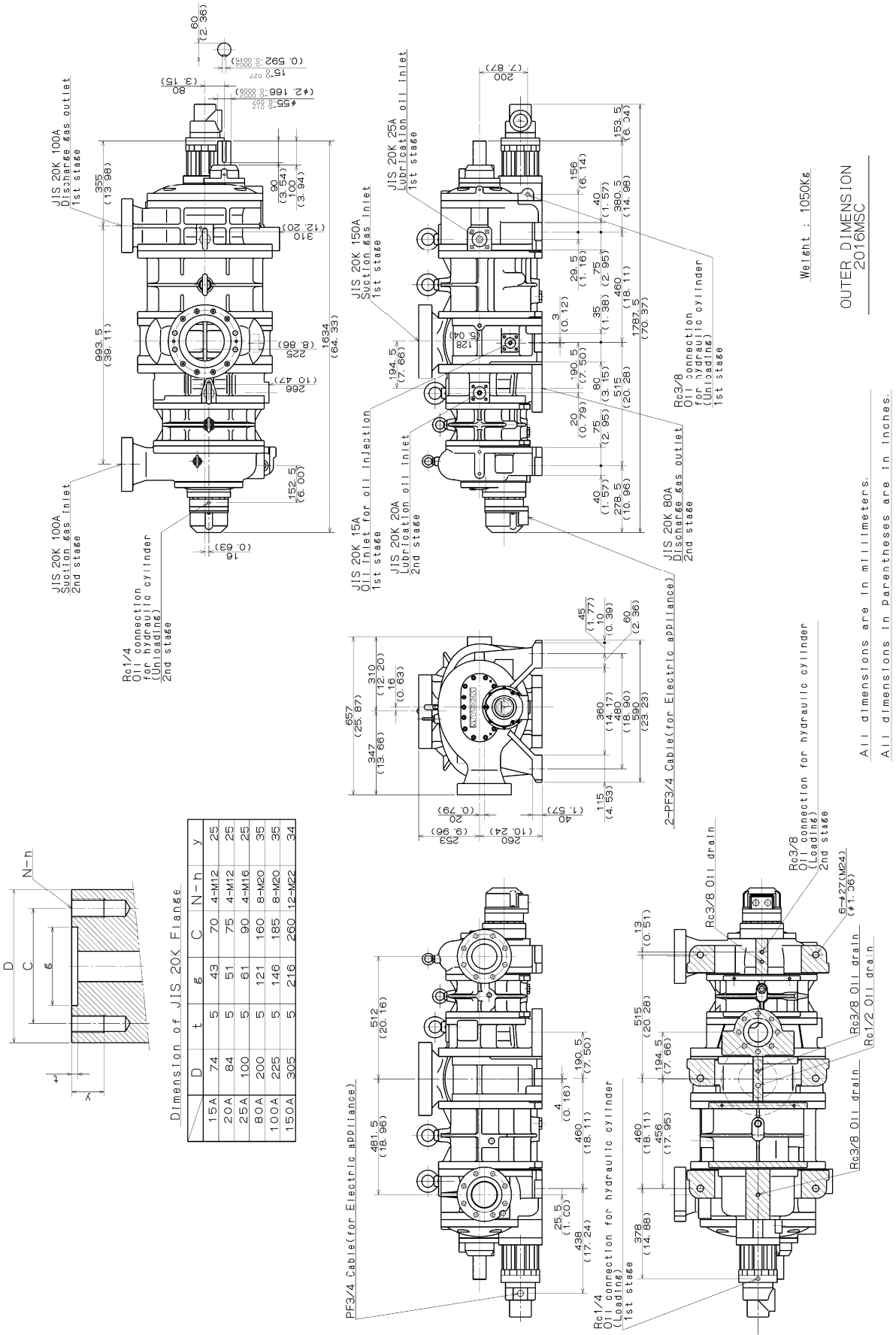

Figure 2-5 Outer Dimensions 2016MSC

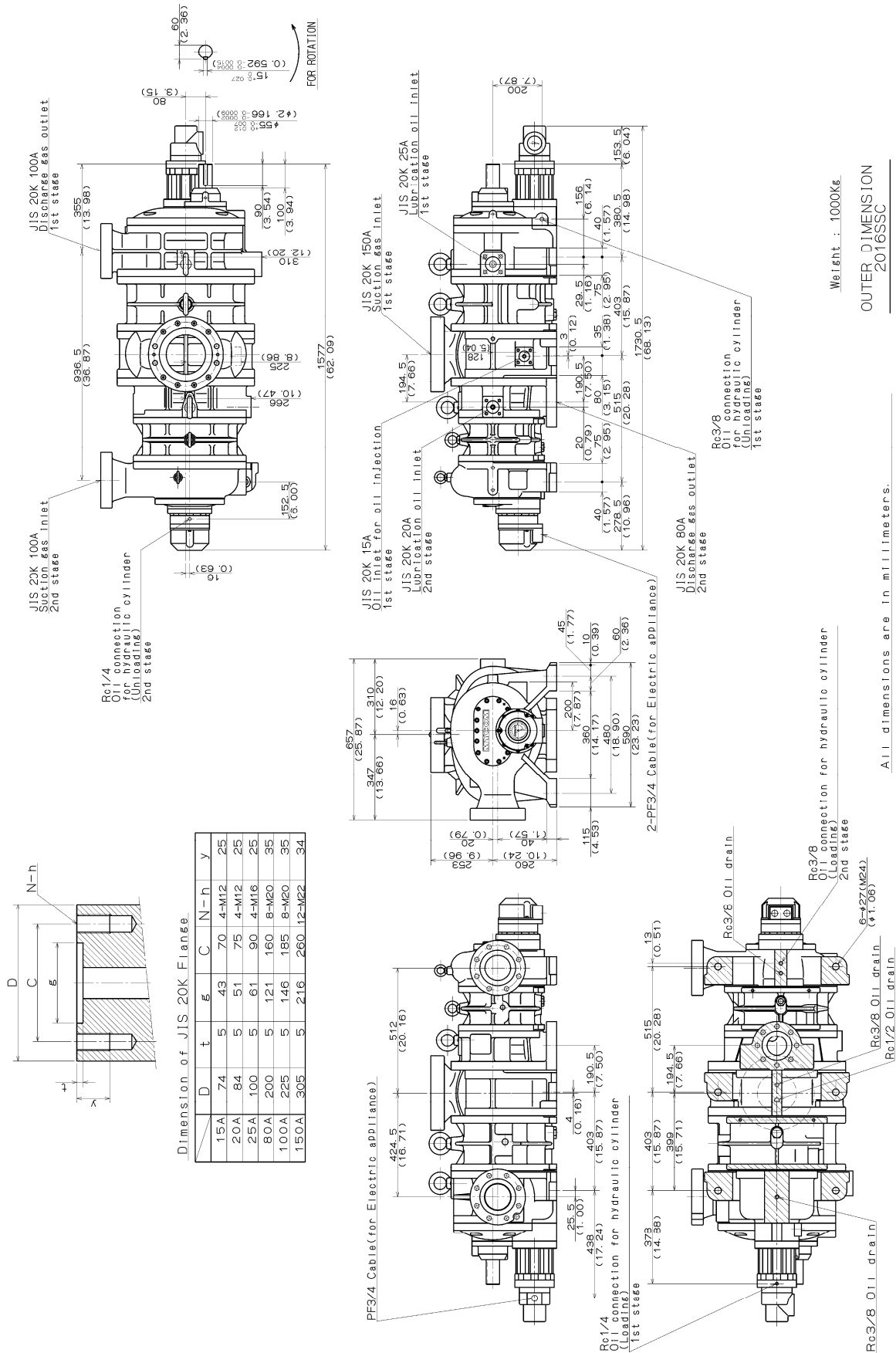

Figure 2-6 Outer Dimensions 2016SSC

## 2.4 Structure of Compressor

[POINT]

- For names of each part of the compressor, refer to Section 7.1 "Development Views, Assembly Sectional Views ", and Section 7.2 "Parts Configuration Table" in this manual.

### 2.4.1 Sectional View

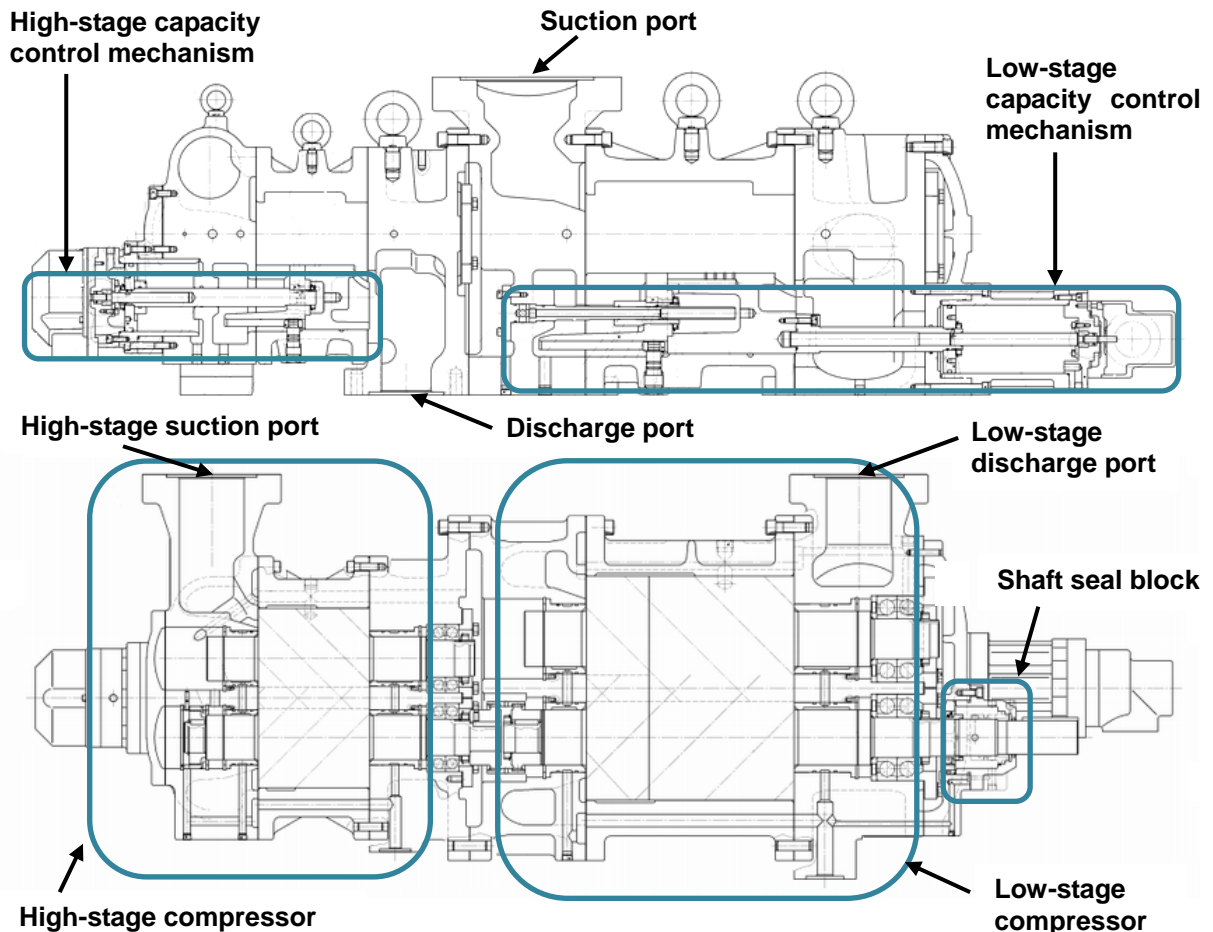

Figure 2-7 2016\*\*C Screw Compressor Sectional View

The 2016\*\*C model, a compound 2-stage compressor, consists of two compressors, (i) a low-stage compressor which suctions gas, working fluid, from the refrigerating unit and compresses (pressure-raises) the gas and (ii) a high-stage compressor which furthermore compresses the gas that has been pressure-raised by the low-stage compressor and sends the resulting gas to the refrigerating system side.

In each casing (low-stage, high-stage), two screw rotors are supported on both ends by bearings. They are meshed with each other in a joint assembly. These two screw rotors are a set of a male rotor having 4 protruding lobe profiles (M rotor) and a female rotor having 6 concave lobe profiles (F rotor). They conduct compressing according to the mechanism explained below.

The standard compressor's M rotor is driven by a 2-pole motor; it operates at  $3000 \text{ min}^{-1}$  (50 Hz) or  $3600 \text{ min}^{-1}$  (60 Hz). F rotor operates at  $2000 \text{ min}^{-1}$  (50 Hz) or  $2400 \text{ min}^{-1}$  (60 Hz), conforming to the operation of M rotor.

\* The actual speed of a motor is less than its calculated speed (synchronous speed). This difference is caused by slipping of the motor rotor.

The shaft of the low-stage compressor's M rotor which is linked with the motor has a shaft seal block that keeps gas and lubricating oil from escaping from inside the compressor.

For high efficient operation, the 2016\*\*C model has a capacity control mechanism for coping with load change on the low-stage, and a capacity control mechanism for reducing startup load on the high-stage.

## 2.5 Mechanisms

### 2.5.1 Basics of the Screw Compressor

The screw compressor is categorized as a positive displacement rotary compressor.

As shown in Figure 2-8, the refrigerant (gas) is continuously compressed by the 3-dimensional spaces that are formed by a pair of male and female screw rotors (with different sectional profiles) and the casing, as the spaces change continuously.

The rotor having 4 protruding lobe profiles is called a male or M rotor, and the rotor having 6 concave lobe profiles is called a female or F rotor. In this manual, they are referred to as M rotor and F rotor.

The compressor is driven by the motor connected to the shaft of the M rotor.

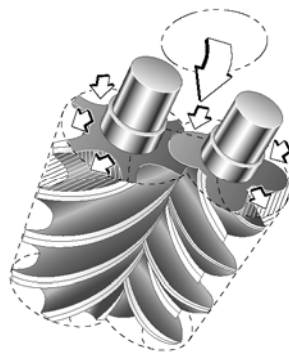

Figure 2-8 Compressor Mechanism

### 2.5.2 Suction Process

As shown in Figure 2-9, the rotors with different lobe profiles are engaged. As the rotors turn, the volume between the M and F rotor lobe profiles and the compressor casing gradually increases starting from the suction side.

As the rotation continues, at a certain point when the volume reaches its maximum, the rotors isolate the gas (volume), which is enclosed by the rotors and the compressor casing, from the suction port and then continues rotation.

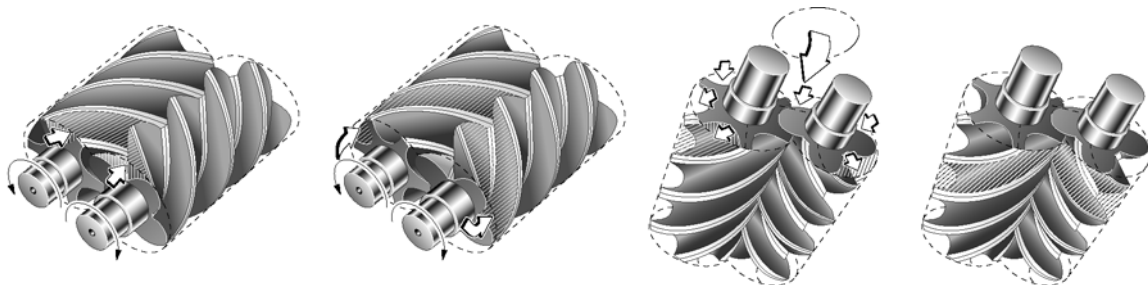

Figure 2-9 Suction Process

### 2.5.3 Compression Process

As the rotors rotate further, the volume between the rotor lobes decreases while the sealing line moves toward the discharge side, which compresses the trapped refrigerant gas.

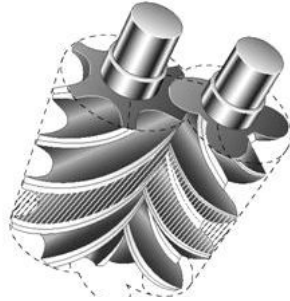

Figure 2-10 Compression Process

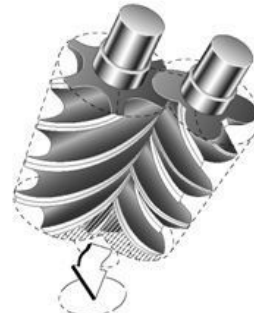

Figure 2-11 Discharge Process

### 2.5.4 Discharge Process

The volume between the rotor lobes decreases to a level predetermined by the discharge port. With the rotations of the rotors, the compressed refrigerant gas is pushed out to the discharge port.

### 2.5.5 About Volume Ratio (Vi)

Volume ratios (Vi) of **MYCOM** C-series screw compressors are indicated in performance tables or catalogs by using port symbols L and M.

The volume ratio represented by each symbol is as follows:

L=2.63, M=3.65.

$$V_i = \frac{\text{Volume of suctioned refrigerant gas immediately before the start of compression}}{\text{Volume of refrigerant gas just before pushed out to discharge port}}$$

Which volume ratio (L or M) should be used is decided according to operating conditions. If the compressor is used with a volume ratio that does not match operating conditions, operation will go inefficiently wasting the power.

The relationship between volume ratios and generally used compression ratios is as follows:

$$V_i = \left( \frac{P_d}{P_s} \right)^{\frac{1}{\kappa}} \quad \text{or} \quad V_i^{\kappa} = \frac{P_d}{P_s}$$

$(V_i)^{\kappa} = \pi_i = P_d/P_s$        $\kappa = C_p/C_v$  of refrigerant gas  
 $V_i = \text{Design volume ratio}$        $\pi_i = \text{Design compression ratio}$

As  $V_i$  is affected by the constant of the refrigerant gas, its value that corresponds to the compression ratio will change depending on the refrigerant gas.

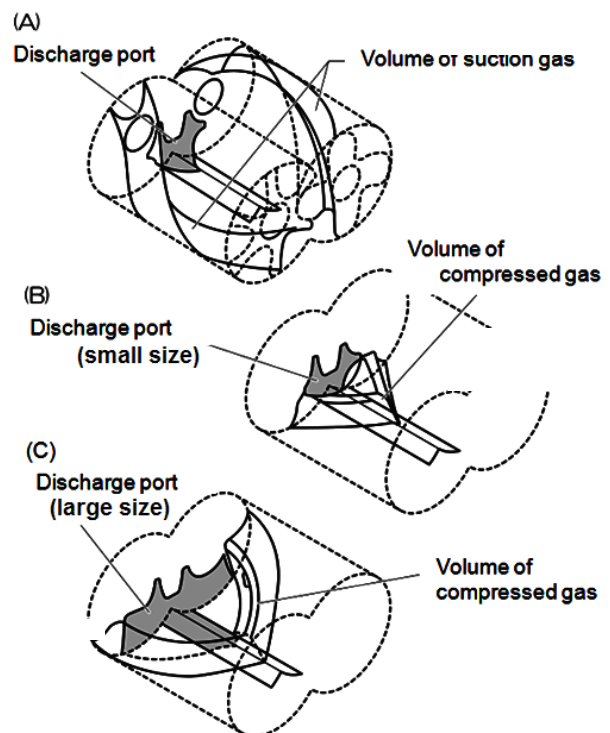
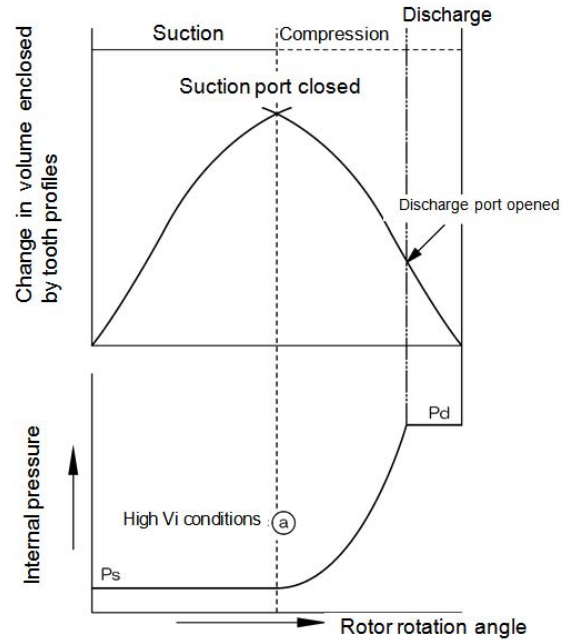
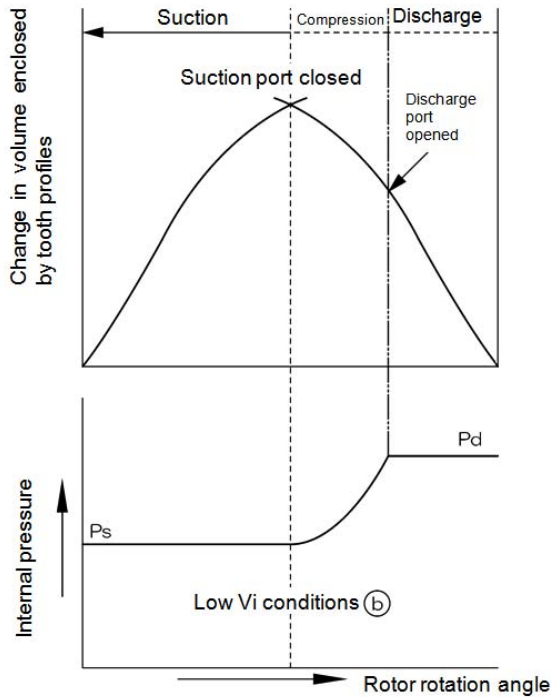

Figure 2-12 Volume Ratio

#### (A) Properly adapted $V_i$ to load condition

Both the required compression ratio and  $V_i$  are low.

Both the required compression ratio and  $V_i$  are high.



**(B) Improperly adapted  $V_i$  to load condition**

$V_i$  is too low compared to the required compression ratio.

$V_i$  is too high compared to the required compression ratio.

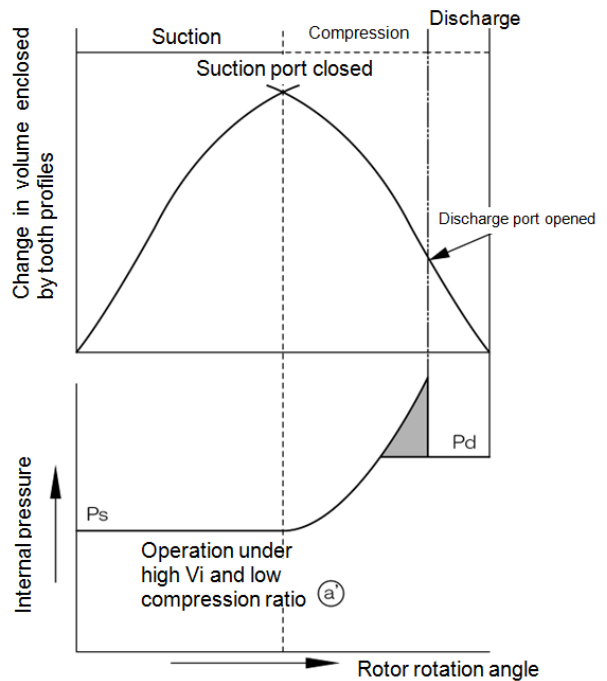
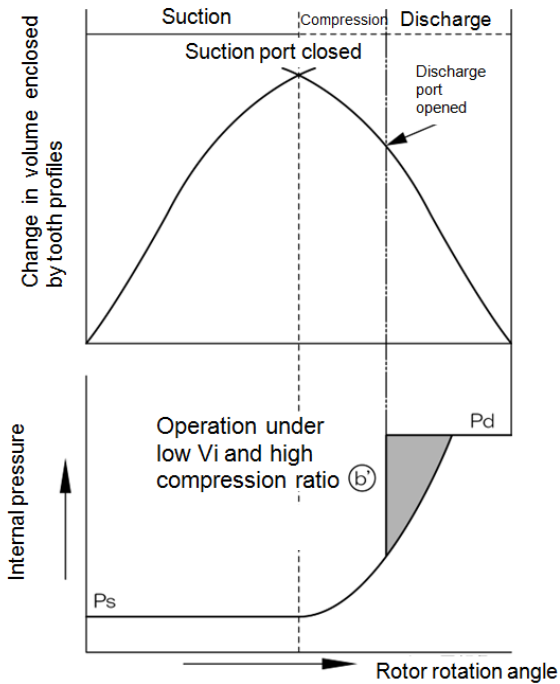

Figure 2-13 Relationship between Volume ratio ( $V_i$ ) and Operation Conditions

## 2.5.6 Capacity Control Mechanism

The capacity control mechanism, by moving a slide valve, lets suction gas (immediately before compressed) bypass and advance to the suction side, to help shorten the rotor portion used for compression. The slide valve is located at the bottom of the casing in which the rotors mesh together, and is constructed to move parallel to the rotor shaft. This movement is changed by a cam mechanism into rotation movement. Its position (namely, capacity control ratio) is indicated externally and, at the same time, fed back to the automatic control circuit by changing the electric resistance.

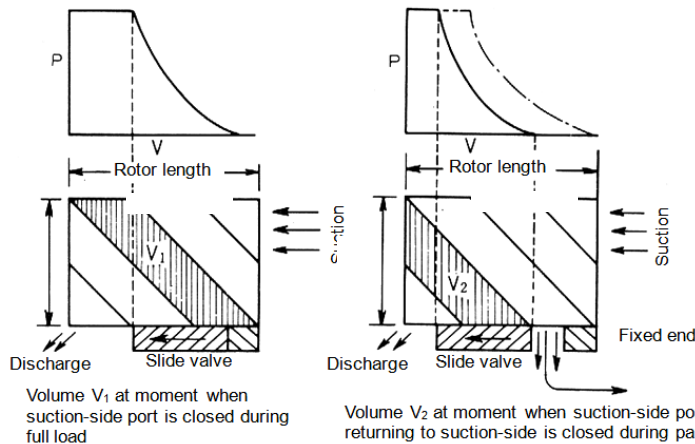

Figure 2-14 Capacity Control Mechanism

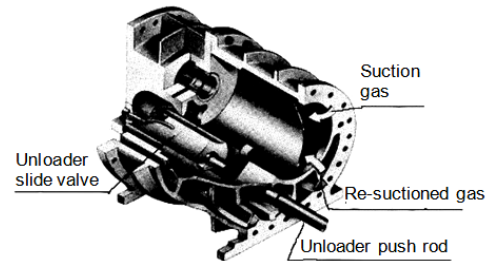

Figure 2-15 Slide Valve in the Main Rotor Casing

The 2016\*\*C model has a capacity control mechanism (indicated load: 20 % to 100 %) for startup load reduction on the high-stage unit, and another one (indicated load: 0 % to 100 %) for coping with load change on the low-stage.

## 2.5.7 Bearing and Balance Piston

For the load acting on the rotor perpendicular to the shaft, sleeve-type white metal-lined bearings are used. For the load acting along the shaft direction, face-to-face combination type of angular contact ball bearings are used.

Special care is taken to cope with the load acting along the shaft direction. Because the M rotor is a kind of helical gear and also because the thrust load produced by discharge pressure is larger than that for F rotor, the load applied onto the M rotor is reduced by using not only a thrust bearing but also a balance piston that applies pressure from the opposing direction.

## 2.5.8 Shaft Seal

To prevent refrigerant gas and oil leakage, a reliable mechanical seal assembly is used for the shaft seal of the M rotor.

Mechanical seal assembly is mainly composed of "rotating ring" installed on the rotor shaft and "stationary ring" installed in the seal cover. Rotating ring rotates with the shaft, and slides each other with the stationary ring while maintaining a micron class gap. The sliding each other place is called as the sliding surface.

For example, the BBSE (Balance Bellow Single Seal) which is currently used as standard seal, employs a stationary ring (mating ring) made of special cast iron, a rotating ring made from carbon, and O-rings for the packing.



## 2.6 Gas and Oil Flow

The compression process of the screw compressor is as described in the preceding paragraphs.

Gas of the compound 2-stage screw compressor 2016\*\*C is sent from the evaporator, and passes through the strainer and check valve. It is drawn in from the upper central area (1) of the compressor, compressed at the lower (2), and then discharged at (3). (3) and (4) are connected with a pipe.

At the mid point of the pipe, that gas is mixed with the gas from liquid cooler which was used for supercooling.

Lubricating oil injected at the low-stage is, while kept mixed with gas, suctioned from (4) into the high-stage.

After being compressed at (5), the gas mixed with lubricating oil is discharged from (6), and is sent from the oil separator to the condenser.

Even if without intermediate gas cooling, oil provides cooling effect.

So, the high-stage discharge temperature is maintained at a temperature not higher than 90 °C.

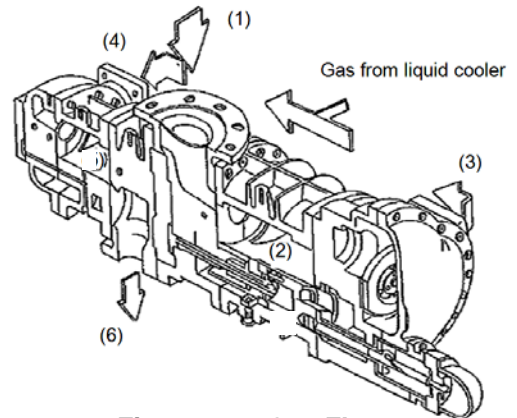

Figure 2-16 Gas Flow

### Oil Supply Route

As shown in Figure 2-17, lubricant is split into five flows. After completing each role, the oil is mixed with discharge gas and leaves the compressor. In standard configuration, oil injection is not performed at the high-stage.

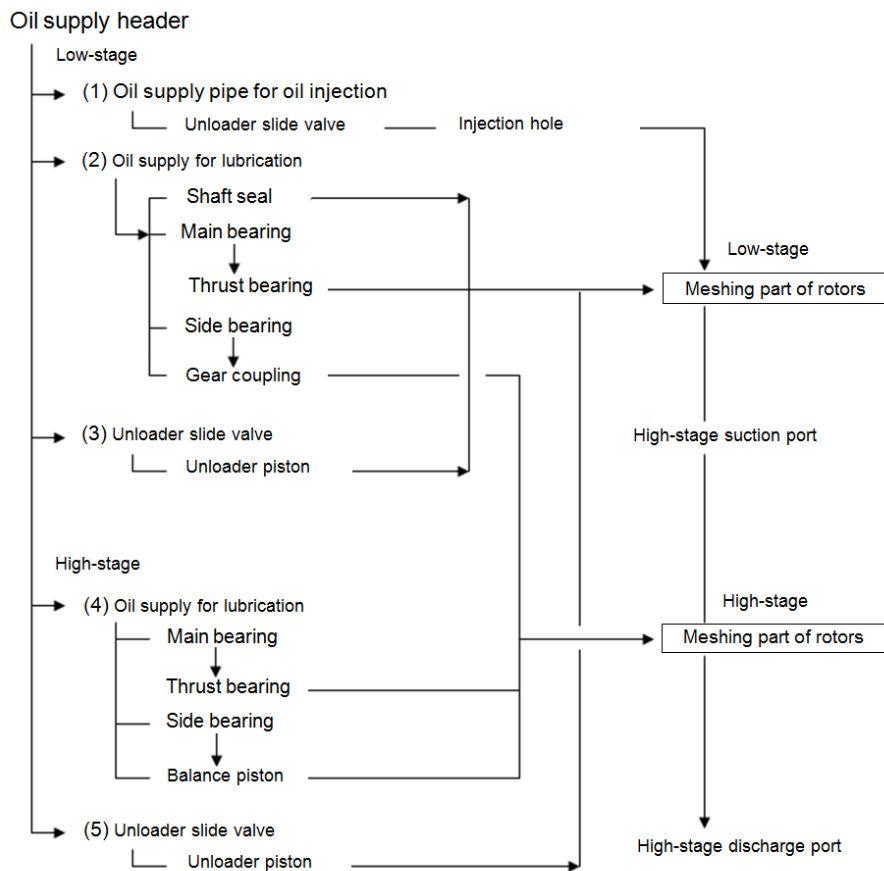

Figure 2-17 2016\*\*C Oil Supply Route

## Chapter 3 Installation

### 3.1 General Precautions for Installation

**【POINT】**

- This chapter (Installation) assumes that the compressor is installed to a standard refrigeration / cold storage/gas compression package unit.  
If the package unit you are actually using is not the standard type refrigeration/cold storage/gas compression package unit, prepare a proper installation manual by referring to the description in this chapter and paying due consideration to safety, before installing the compressor.  
If there are any questions, please contact our local sales offices or service centers.
- In some cases, it may be required that installation is performed by qualified personnel. Make sure that the work is performed by qualified personnel in compliance with local laws, ordinances and other regulations/requirements.
- Before installing the compressor, please read this chapter and related documents attentively and fully understand their contents.
- Electrical works should be performed only by electrical engineers.

### 3.2 Installation Works

#### 3.2.1 Unpacking

Check that there are no abnormalities such as damage on the compressor.

**【POINT】**

- If there are abnormalities or deficient parts on the compressor, please contact our sales offices or service centers immediately.
- Unnecessary packing materials should be discarded according to the laws and ordinances, or your company's rules.

#### 3.2.2 Storage

If you need to store the compressor before installation, perform the followings:

- Store it indoors.
- Infuse nitrogen gas into the compressor and seal it. (Pressure: Approximately 0.15 Mpa )

#### 3.2.3 Transportation



- **Dropping of the lifted compressor may cause death or serious injury to the worker. Do not stand under the lifted compressor.**

1. For lifting the compressor within the safety limit, use lifting equipment and tools appropriate for the mass of compressor.
2. Secure sufficient space for safe lifting.

3. Always check the wire ropes before using them. Thoroughly check the wire ropes for problems such as kinks, knots and broken strands. Do not perform lifting before checking the wire ropes. If you cannot make a correct evaluation or judgment, entrust an expert to check.
4. To lift the compressor, attach the wire ropes to the appended eye bolts by using appropriate shackles and hooks. Use the eye bolts only for lifting the compressor. Refer to Figure 3-1 and Photo 002 in next page.  
Do not use the eye bolts when lifting the compressor together with additive equipment.

### CAUTION

- **The compressor eye bolts must not be used for lifting the package unit. To lift the package unit, use the lifting chains provided around the base or other lifting means provided on the base.**

5. Check path of compressor installation to make sure it is free of obstacles in consideration of the compressor size.
6. Before lifting, check that the hook is located above the gravity center of the compressor.
7. Direct all the workers to stay clear of the work site before lifting.
8. Before lifting the compressor, alert all workers in area of dangers during lifting process by signal (such as calling at the beginning of the work or making a signal by hand). Do not lift the compressor unless the signals (such as calling out or hand signals) are completely understood by the workers at site.
9. Slowly reel up the wire ropes until immediately before the compressor leaves the ground.
10. Then, reel up the wire ropes a little further until the compressor is slightly up away from the ground. Check that the compressor is not tilted. If the compressor is tilted, return the compressor to the ground and correct the tilt by adjusting the wire ropes. After that, restart the lifting operation.
11. Be sure to lift up the compressor slowly. If it is lifted rapidly, it may damage the lifting tools such as wire ropes or a part of the compressor.
12. When the lifting work starts, observe to see if wire ropes and lifting tools are normal. Be sure that the compressor is not tilted.
13. When moving the lifted compressor, always use guiding ropes.
14. When moving the compressor, turn away workers from the movement direction and check safety.
15. Do not lift the compressor above the safety passage unless absolutely necessary.
16. Do not lower the compressor on the safety passage. Always keep the safety passage free of obstacles.
17. Remove any obstacles before lowering the compressor onto the ground. The compressor should not be tilted or unstable.
18. Before lowering the compressor, announce to the workers around the working area in advance.
19. When lowering the compressor onto two or more blocks, align the tops of blocks so that the compressor becomes stable horizontally on them.
20. Slowly lower the lifted compressor so that it is not damaged by shock.

■ Outer Dimensions, Mass and Lifting Position

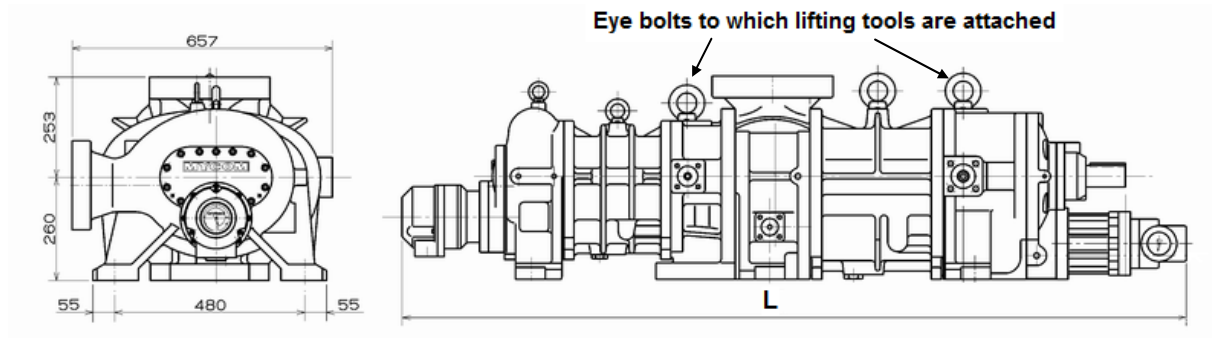

	2016LLC	2016LMC	2016LSC	2016MMC	2016MSC	2016SSC
Product mass (kg)	1180	1140	1100	1090	1050	1000
L (mm)	1980.5	1913.5	1842.5	1858.5	1787.5	1730.5

Figure 3-1 Outer Dimensions, Mass and Lifting Position of Compressor



Photo 002 Lifting Position

### 3.2.4 Preparation for Installation

■ **Installation Space**

Secure sufficient working space for easy operation, cleaning, maintenance, and inspection.

■ **Illumination**

Prepare illumination devices which allow easy operation, cleaning, maintenance, and inspection.

■ **Ventilation**

If natural ventilation is insufficient, install ventilation fans according to the relevant regulations.

■ **Piping**

**Table 3-1 List of Connecting Pipes (Compressor)**

Item	Dimensions	Remarks
Suction gas inlet	JIS 20K 150A (6")	See Figure 3-2.
Low-stage gas outlet	JIS 20K 100A (4")	See Figure 3-2.
High-stage gas inlet	JIS 20K 100A (4")	See Figure 3-2.
High-stage discharge gas outlet	JIS 20K 80A (3")	See Figure 3-2.
Lubrication oil supply port for low-stage bearing (journal)	JIS 20K 25A (1")	
Lubrication oil supply port for low-stage capacity control (load)	Rc1/4	
Lubrication oil supply port for low-stage capacity control (unload)	Rc3/8	
Oil supply port for oil injection	JIS 20K 15A (1/2")	
Lubrication oil supply port for high-stage bearing (journal)	JIS 20K 20A (3/4")	
Lubrication oil supply port for high-stage capacity control (load)	Rc3/8	
Lubrication oil supply port for high-stage capacity control (unload)	Rc1/4	

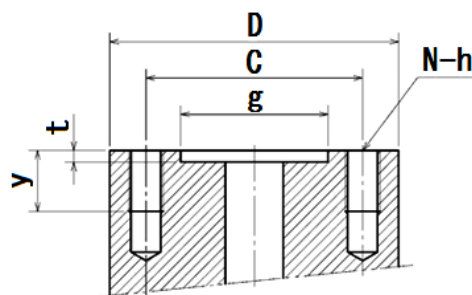

	D	t	g	C	N-h	y
15A	□ 74	5	43	70	4-M12 × P1.75	25
20A	□ 84	5	51	75	4-M12 × P1.75	25
25A	□100	5	61	90	4-M16 × P2	25
80A	200	5	121	160	8-M20 × P2.5	35
100A	225	5	146	185	8-M20 × P2.5	35
150A	305	5	216	260	12-M22 × P2.5	34

**Figure 3-2 JIS 20K Flange Dimensions of Compressor (mm)**

## 3.2.5 Installation

### 3.2.5.1 Installation

Check that the surface of the package unit, where the compressor is to be installed, is even and horizontal. If it is uneven and non-horizontal, tightening the bolts may lead to compressor deformation, which may prevent normal operation.

### 3.2.5.2 Shaft Alignment between Compressor and Driving Machine

**! DANGER**

- Turn off the main power and control power of the driving machine before shaft alignment work between the compressor and the driving machine. Be careful so that the power of instruments does not turn on during shaft alignment work. If the power turns on during shaft alignment work, the driving machine starts moving and there is a risk of being entangled with the rotating shaft.
- At the time of turning ON/OFF each electric power breaker, make sure to prevent electric shock.

**! CAUTION**

- For shaft alignment work between the compressor and driving machine, use designated tools in normal condition. If a worn or damaged tool or a tool unsuitable for the work is used, there is a risk of being injured.

In the case shaft alignment between the compressor and the driving machine, be sure that the deviations within the range shown in the Table 3-2. However, if alignment tolerance of the driving machine side is more stringent than Table 3-2, please adjust to the request within the allowable value of the driving machine side.

Table 3-2 Tolerance of Misalignment

	Tolerance
Offset	6/100 mm
Angularity	3/100 mm (reference: $\Phi 100$ mm)

The Figure 3-3 and 3-4 show how to measure offset and angularity when performing the centering of the shafts of the driving machine and this product using a dedicated hub, a dial gauge and a magnet stand.

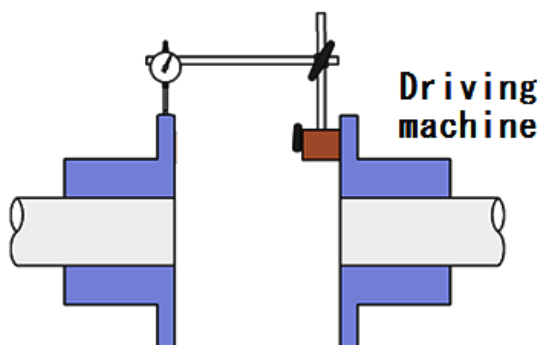

Figure 3-3 Measurement of Offset

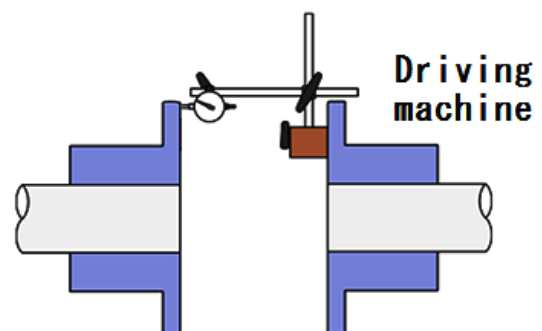

Figure 3-4 Measurement of Angularity

### 3.2.5.3 Piping Connection

#### ■ Refrigerant Piping

Observe the following when connecting the refrigerant piping to the compressor.

- The compressor is one of the few devices installed within the package unit that have moving components. These moving components are adversely affected by foreign substances within the system (scale, dust, spatter, etc.). Therefore, when connecting the piping, do not allow any of such foreign substances to enter inside.
- Some compressors (mainly those for export) are charged with nitrogen gas to prevent rust. Be sure to release the pressure before starting piping work.
- Be sure not to allow moisture to enter the piping. There is a high probability that it will cause trouble after the start of operation. Be sure to assemble piping when it is dry.
- Cover flanges are attached to the compressor's low-stage gas outlet and high-stage gas inlet. After installation, be sure to attach piping (intermediate piping) that links the both connection ports.
- Improper piping may cause operating problems such as oil not returning to the compressor or liquid flow-backs.
- When connecting the piping to the compressor, use piping that is the same size as the compressor connection port. If the pipe size of the piping is smaller than the compressor connection port, the flow of lubricating oil or refrigerant will be obstructed leading to problems.
- Do not let the mass of the piping connected to the compressor applied onto flanges or joints. Be sure to prepare proper supports for piping.

### 3.2.5.4 Equipment and Devices for Protection of the Compressor

#### ■ Oil Filter

According to the requirements of the use of the package unit or the standard to apply, install an oil filter of appropriate filtration precision in the lubrication system of the compressor.

In the case of general applications such as closed-cycle refrigeration systems, we recommend to use an oil filter with beta ratio in the range of  $\beta_{20} \geq 150$  that conforms to requirements of NAS 1638 class 8 or ISO 4406 17/15/13.

When the package unit requires API 619 4th/5th edition conformity, use an oil filter with beta ratio in the range of  $\beta_{10} \geq 200$ .

The oil filter may be clogged just after commissioning. We recommend installing two oil filters in parallel. This will enable replacement of either filter during operation.

#### ■ Oil Heater for Oil Separator

To preserve the temperature of the lubricating oil before starting the compressor, install an oil heater on the oil separator. Make sure to install a protection function (thermostat, etc.) to prevent overheating.

#### ■ Suction Strainer

When compatible (inter-soluble) oil is used, the mesh size of suction strainer should be not less than 200 meshes. When incompatible (non-inter-soluble) oil is used, it should be not less than 100 meshes.

For details about compatible and incompatible oils, refer to Section 4.1 "Lubricating Oil (Refrigerant Oil)" in this manual Chapter 4.

During commissioning, small particles and scale may come from the system. We recommend to install a finer filter temporarily.

### ■ Compressor Protective Devices (Safety Devices)

To protect the compressor, install the protective devices as indicated in Section 1.4.3 "Compressor Protective Devices" in this manual Chapter 1.

### 3.2.6 Airtightness Test

Perform an airtightness test on the package unit before starting commissioning. To prevent water entry in the package unit, use nitrogen gas or dry air for the airtightness test.

### 3.2.7 Lubricating Oil Charge

#### CAUTION

- TO select the lubricating oil to be used, refer to Section 4.1 "Lubricating Oil (Refrigerant Oil)" in this manual.
- When refilling lubricating oil, ensure that it is clean and does not contain foreign matters.
- Be careful that air and water are not mixed in when refilling.
- To ensure that the lubricating oil does not absorb air moisture, keep it indoors in an airtight container until use.

#### 3.2.7.1 Initial Charge of Lubricating Oil

Depending on the package unit configuration and operating condition, specify the procedure, method and amount of the initial charge of lubricating oil, and make sure to provide users of this product with such information.

In determining the procedure and work procedure of the initial charge of lubricating oil, please care oil is to be filled in the oil filter and oil cooler always.

#### 3.2.7.2 Additional Charge of Lubricating Oil

Specify the procedure of the additional filling of lubricating oil based on the configuration of the package unit, and make sure to provide users of this product with the information.

### 3.2.8 Charge of Refrigerant

Depending on the use working fluid and equipment configuration of your package unit, specify the work procedure that considered safety enough, and conduct the refrigerant initial filling work accordingly.

In addition, specify the procedure of the additional filling of refrigerant, make sure to provide users of this product with the information.

### 3.2.9 Check after Installation

Depending on the package unit to which this product is installed, formulate the necessary confirmation items and methods for package unit after installation and conduct them accordingly before the commissioning. In addition, make sure to record and keep the results of your confirmation.



## Chapter 4 Compressor and Package Unit Operation

### 4.1 Lubricating Oil (Refrigerant Oil)

Lubrication management is very significant to keep the compressor in a good operating condition. Take the following notes when managing lubricating oil.

#### 4.1.1 Precautions for Selecting the Lubricating Oil

- Selection of the lubricating oil should depend on the type of the refrigerant, the type of the evaporator used with the compressor, and the conditions under which the compressor is operated. Also to be considered when selecting lubricating oil are the properties of the oil that include not only the viscosity but also such characteristics as compatibility in refrigerant, separability from refrigerant, low temperature fluidity, high temperature thermal stability, etc.  
We therefore recommend contacting our sales offices or service centers for choice of a specified brand for your system.
- Lubricating oil used for compressors must have a viscosity appropriate for lubricating the bearings and other components in the compressors. The viscosity to be considered in this case should be the viscosity the oil shows at the oil inlet of the compressor. The viscosity of the lubricating oil significantly changes depending on the type of the refrigerant used in combination with the lubricating oil. If the refrigerant dissolves in the lubricating oil (or the lubricating oil and refrigerant are compatible), the viscosity of the lubricating oil drops to a level remarkably below the level required for operation of the compressor under some operating conditions. On the contrary, if the refrigerant does not dissolve in the lubricating oil (or the lubricating oil and refrigerant are incompatible), the viscosity may become too high when the supply oil temperature is low. For this reason, the lubricating oil must be selected such that it is supplied to the compressor with an appropriate viscosity (kinematic viscosity of 13 to 40 mm<sup>2</sup>/s) in the operating state.
- The circulation of the lubricating oil for the entire system must be considered. After lubricating and cooling each part of the compressor, the lubricating oil is discharged with refrigerant gas. Most of the oil which is discharged from this compressor is trapped by the oil separator and is cycled to the compressor. A small quantity of refrigerant oil goes to the condenser and the evaporator. The lubricating oil is required to have sufficient fluidity and stability inside each part in the refrigerating cycle where temperatures differ.
- Note that some lubricating oils cannot be used depending on the combination with the refrigerant. The following caution is an example case that is required especially attention.

#### CAUTION

- Be careful since polyolester synthetic oil (POE) must not be used with ammonia refrigerant.

#### 4.1.2 Recommended Lubricating Oils

When selecting lubricating oil, not only compatibility with refrigerant but also effects on O-rings must be considered. To prevent compressor malfunctions, we recommend the lubricating oil described below.

##### 4.1.2.1 Recommended Lubricating Oils for Ammonia Refrigerant

###### ■ Polyalkylene Glycols (PAG) Based Synthetic Oil (compatible oil)

Brand	Kinematic viscosity (40°C) mm <sup>2</sup> /s	Manufacturer	Type
JOMO Freol PN46	46	JX Nippon Oil and Energy Corporation	PAG

■ **Mineral oils (incompatible oils)**

Brand	Kinematic viscosity (40°C) mm <sup>2</sup> /s	Manufacturer	Type
SUNISO 3GS	30	Sun Oil	Naphthene base
SUNISO 4GS	55	Sun Oil	
REFOIL NS 3GS	30	Nippon Oil	
GARGOYLE ARCTIC C HEAVY	46	Exxon Mobil	
GARGOYLE ARCTIC 300	68	Exxon Mobil	
CAPELLA WF46	46	Texaco	
CAPELLA WF68	64	Texaco	
CP-1009-32	34	CPI	Hydrotreated paraffinic base
CP-1009-68	69	CPI	
REFLO 46A	46	Petro Canada	
REFLO 68A	58	Petro Canada	
CAPELLA PREMIUM	67	Texaco	
RHT-68	68	Kluber	
REFLO XL	59	Petro Canada	

■ **Synthetic oils (incompatible oils)**

Brand	Kinematic viscosity (40°C) mm <sup>2</sup> /s	Manufacturer	Type
Acemire 300	59	Acemire	AB
Mycold AB68	53	BVA	
ZERICE S46	46	Exxon Mobil	
ZERICE S68	68	Exxon Mobil	
BERREL FREEZE 46S	46	Matsumura Oil Co., Ltd.	
CP-4700-32	31	CPI	
CP-4700-68	56	CPI	
Gold-Cold 300	53	Golden West	
GARGOYLE ARCTIC NH68	64	Exxon Mobil	PAO+AB
REFLO SYNTHETIC 68A	62	Petro Canada	
Gargoyle arctic SHC 224 <b>Note</b>	30	Exxon Mobil	PAO
Gargoyle arctic SHC 226(E) <b>Note</b>	68	Exxon Mobil	

**Note:** Use only a seal of the standard BBSE type.

#### 4.1.2.2 Oils for systems using Hydrofluorocarbon (HFC) refrigerants

■ **Polyolester synthetic oil (POE) for R404A, R507A and R410A (compatible synthetic oil)**

Brand	Kinematic viscosity (40°C) mm <sup>2</sup> /s	Manufacturer	Type
SUNISO SL-68S	67	Sun Oil	POE
EMKARATE RL68H	72	Lubrizol	

■ Polyolester Synthetic Oil (POE) for R134a (Incompatible synthetic oil)

Brand	Kinematic viscosity (40°C) mm <sup>2</sup> /s	Manufacturer	Type
JOMO Freol α100	107	JX Nippon Oil and Energy Corporation	POE

**CAUTION**

- When using lubricating oil of a brand not described in this section, or when using lubricating oil along with refrigerants or gases not described in this section, please contact us.

### 4.1.3 Change of Lubricating oil Brand

When changing the lubricating oil brand in currently use for some reason, attention must be paid to the following points.

**CAUTION**

- The change of lubricating oil brand may cause problems in operating conditions and the compressor. When changing the lubricating oil brand in use, make sure to contact us because appropriate steps must be surely followed.
- Package unit composition differs depending on the characteristics of lubricating oil (compatible/incompatible with refrigerant). As a general rule, changing compatible oil to incompatible oil or vice versa is not allowed.

- Lubricating oil contains various additives to fulfill necessary lubricating conditions. Types of additives and their mixing ratio depend on each oil brand. We, therefore, recommend to avoid mixed use of different brands of lubricating oil. If mixed brands of lubricating oil are used, the different additives in the lubricating oil may react with each other and produce foreign substances like slurry.
- If it is necessary to change the brand of lubricating oil, collect as much as oil as possible from the compressor as well as from the condenser, evaporator, and all other refrigerating unit components before charging the new lubricating oil. After 100 to 200 hours of operation, replace the oil again.
- If lubricating oil manufacturers differ, contact both of them and inquire whether the changing is appropriate. The same confirmation is required for changing the brand even if it is of the same manufacturer.
- There is no problem in changing the viscosity level within the same brand. However, make sure that the viscosity grade will not cause problems during operation (Example : SUNISO 3GS→SUNISO 4GS).

#### 4.1.4 Precautions for Handling lubricating oil

- When refilling lubricating oil, ensure that it is clean and does not contain foreign matters.
- Be careful that air and water are not mixed in when refilling.
- To ensure that the lubricating oil does not absorb air moisture, keep it indoors in an airtight container until use.

##### 4.1.4.1 Precautions for Handling Polyalkylene Glycol (PAG)

PAG oil is much more hygroscopic than mineral oils and any moisture mixed in the oil may lead to rust, corrosion and wear within the package. When handling PAG oil, pay special attention to the following points.

- Do not perform oil charging in rainy weather or at a place with high humidity to prevent absorbing moisture.
- Before charging, remove as much moisture as possible from the system by exhausting it with a vacuum pump for a sufficient length of time and leaving the system in vacuum condition overnight.
- Do not open the lid of pail (oil container) until just before charging. Once the can is opened, finish the oil charge as quickly as possible. (Finish the charge of a single can of oil within 15 minutes.)
- Cover any gaps between the pail opening and the charge hose so that foreign substances or moisture cannot enter. A more effective way is to substitute any space inside the pail with nitrogen gas .
- Always charge all oil from the pail. Even if some oil remains, do not use it subsequently.
- If any oil drops on a painted surface, wipe it away as soon as possible. Otherwise the paint may come off.

##### 4.1.4.2 Precautions for Handling Polyolester (POE) Oil

This type of oil has high hygroscopicity as polyalkylene glycol, and also exhibits hydrolyzability under high temperature environments. Moisture entry must be avoided. Therefore, special attention must be paid as with PAG when handling POE.

- Finish the charging in as short a time as possible after opening the pail to minimize exposure to air.
- Make sure that all oil in a pail is used in a single charging. Any remaining oil must be stored indoors with the can lid closed tightly. Do not attempt to store it for a long time.
- Because POE can hydrolyze, make sure to perform an oil analysis regularly in the package to see if any abnormal conditions are present.

## 4.1.5 Lubricating Oil Management Criteria

Lubricating oils that are managed by the criteria are classified into the following categories:

- (1) Synthetic oils: Polyalkylene glycols (PAG)
- (2) Mineral oils: Naphthenic base oils and paraffinic base oils
- (3) Synthetic oils: Alkylbenzene (AB) and Polyalphaolefine (PAO)
- (4) Synthetic oils: Polyolesters (POE)

- **Oil sampling and analysis is recommended every six months.**
- **If the following control criteria are not satisfied, replace the oil.**
  - ◆ Note that the water content of PAG shall be excluded from the above oil replacement criteria. Refer to the Note \*1 in the following table.

The analysis items and the criteria are shown in the following tables. Please note that these management criteria may be changed without notice.

●Table 4-1 Synthetic Oil (PAG)

Item	Criteria
(a) Color phase	ASTM color scale: 4.0 or less
(b) Total acid number (TAN)	0.1 mg KOH/g or less
(c) Kinematic viscosity	Within $\pm 10$ % from that of fresh oil
(d) Water content	2000 mass ppm or less <b>Note1</b>
(e) Degree of contamination	Degree of contamination measured by mass method (Millipore value) shall be 15 mg/100 mL or less

●Table 4-2 Mineral Oil and Synthetic Oil (AB, PAO)

Item	Criteria
(a) Color phase	ASTM color scale: 6.0 or less
(b) Total acid number (TAN)	0.3 mg KOH/g or less
(c) Kinematic viscosity	Within $\pm 15$ % from that of fresh oil
(d) Water content	100 mass ppm or less
(e) Degree of contamination	Degree of contamination measured by mass method (Millipore value) shall be 15 mg/100 mL or less

●Table 4-3 Synthetic Oil (POE)

Item	Criteria
(a) Color phase	ASTM color scale: 4.0 or less
(b) Total acid number (TAN)	0.2 mg KOH/g or less
(c) Kinematic viscosity	Within $\pm 10$ % from that of fresh oil
(d) Water content	200 mass ppm or less
(e) Degree of contamination	Degree of contamination measured by mass method (Millipore value) shall be 15 mg/100 mL or less

Note 1: Synthetic oils (compatible with ammonia) are so highly hygroscopic that they can absorb moisture at the time of sampling. In addition, the ammonia content they have absorbed may be detected as the water content at the time of the analysis, making it difficult to precisely measure the water content. Thus, use the criterion value only as a reference.

## **4.1.6 Lubricating Oil Replacement Timing**

### **4.1.6.1 After Starting the Initial Operation**

As the oil can easily be contaminated and degraded relatively quickly during the initial operation due to scales and deposits remaining in piping and vessels, be sure to sample and analyze the oil after 500 hours of operation.

If it is found as a result of the analysis that the criteria given in Tables 4-1 to 4-3 are not satisfied, the oil must be replaced.

### **4.1.6.2 During Normal Operation**

Lubricating oils will degrade gradually as the system is operated over time.

The rate of degradation depends on the operating condition, type of oil and amount of foreign matters and moisture contained in the oil.

The lubricating oil must be sampled and analyzed every six months. If it is found as a result of the analysis that the control criteria given in Tables 4-1 to 4-3 are not satisfied, the oil must be replaced.

If the oil filters are frequently clogged or the oil color quickly becomes darker and unclear, replace the oil after removing the cause of the problem.

## 4.2 Precautions for Operation

If the package unit is used in the refrigeration cycle, please keep in mind the contents of this section in particular.

### 4.2.1 Prevention of Liquid Flow-back

Liquid flow-back is a phenomenon where refrigerant that did not completely evaporate with the gas reaches the compressor. Liquid flow-back may cause insufficient lubrication of the compressor, abnormal vibrations and noises, and abnormal foaming of lubricating oil (too much oil loss). To prevent liquid flow-back, properly adjust the expansion valve of each liquid cooler. For details, refer to Chapter 6 "Troubleshooting" in this manual.

### 4.2.2 Purging of Non-Condensable Gases



- **Some types of refrigerants emit bad smells or toxic gases. Make sure to ventilate the air during work.**

If there is a leak on the low-pressure side of the refrigeration cycle, air may enter the package unit.

If non-condensable gas like air enters the package unit, the condensing pressure rises and the energy consumption increases. This leads to uneconomical operation.

Follow the procedure below to check for non-condensable gases.

1. When the compressor is stopped, allow the cooling water to flow to the condenser for at least 15 minutes. Check the condensing pressure by using the pressure gauge of the compressor.
2. Check the cooling water temperature.
3. Compare the condensing pressure checked in step 1 above with the refrigerant saturation pressure that depends on the cooling water temperature (as shown in the table below).

**Table 4-1 Typical Refrigerant Temperature and Saturation Pressure**

Temperature °C	Pressure MPa				
	Ammonia	R404A	R507A	R410A	R134a
0	0.328	0.509	0.523	0.699	0.192
4	0.396	0.590	0.606	0.807	0.237
8	0.472	0.678	0.696	0.924	0.287
12	0.557	0.775	0.795	1.053	0.342
16	0.652	0.881	0.903	1.193	0.403
20	0.756	0.996	1.021	1.346	0.471
24	0.871	1.121	1.148	1.513	0.545
28	0.998	1.256	1.286	1.693	0.626
32	1.137	1.401	1.435	1.887	0.714
36	1.289	1.559	1.595	2.098	0.811
40	1.454	1.728	1.768	2.324	0.916

■ Unless otherwise noted, the pressure unit MPa represents the gauge pressure in this manual.

4. When the pressure inside the condenser and the refrigerant saturation pressure that depends on the cooling water temperature are approximately equivalent, non-condensable gases do not exist. When the pressure inside the condenser is 0.05 MPa or more higher than the refrigerant saturation pressure that depends on the cooling water temperature, there is a possibility of non-condensable gases entering the unit. In that case, purge the non-condensable gases from the condenser.

## 4.3 When Stopping the Compressor for a Long Time

When stopping the compressor for a long period of time, make sure to perform the following steps.

- Turn off the motor main power.
- Turn off the heater power and control panel power.
- Close the suction and discharge side shut-off valves.

If the operation stop period is 1 month or longer, perform the following checks.

- Operate the oil pump for 10 seconds per week.  
After that, rotate the compressor shaft (10 rotations or more).
- Measure the package unit pressure once per month.
- Check for refrigerant leakage once per month.

When restarting the compressor after an operation stop period of 1 year or longer, check the system for refrigerant leak and analyze the lubricating oil.

If it is found as a result of the analysis that the control criteria given in this Chapter, Section 4.1.5 Tables 4-1 to 4-3 are not satisfied, the oil must be replaced.

Also check the motor insulation resistance.

Supply power to the oil heater at least 1 day before operation start.

Before starting the operation, confirm that the refrigerant is not condensed in the package unit by checking the package temperature and pressure.



## Chapter 5 Maintenance and Inspection

### 5.1 Precautions for Maintenance and Inspection

When reading this Section, also refer to Section 1.1 in this manual Chapter 1.

#### DANGER

- When entering the machine room for maintenance services, ensure that sufficient ventilation has been started and measure the oxygen concentration so that there is no risk of oxygen deficiency. The ventilation must be continued steadily until the work is completed.
- For performing the inspection work, be sure to prepare safety shoes, protective glasses, gas mask and other proper protective equipment and do not fail to use them whenever they are required.
- After stopping the machine and before working on a regular inspection or overhaul, be sure to shut off the main motor power, control power, and other power to each equipment and valve. After they are shut off, be sure to make the switches inoperable by others. Also, be sure to attach notification tags to prohibit operation (lock-out/tag-out).
- When any manual stop valve has been closed, be sure to make the valve inoperable by others and put a notification tag to prohibit the operation (tag-out).
- When the compressor is to be overhauled, check that the internal pressure of this product is at the atmospheric pressure before starting the work.
- When using lifting devices, e.g. a crane, etc. and/or lifting tools, ensure that they can sufficiently withstand the load.
- When lifting a heavy load object, do not allow anyone's body to put under it.
- The work to turn each power supply ON/OFF or operate a lifting unit must be exclusively performed by qualified personnel.
- When using electric tools, ensure that they are properly managed in accordance with each instruction manual. Especially before using and while using, be sure to follow the care instructions on the safety of each instruction manual.

#### WARNING

- Be sure to use only **MYCOM** genuine parts for replacement. Using parts that are not genuine can cause damage to this product or other devices during operation.
- Do not convert or modify this product or its components without prior permission from MAYEKAWA. Otherwise, it can lead to an unexpected accident.
- Exercise sufficient care for handling a heavy load, and use such a lifting device as a crane or work with an adequate number of personnel commensurate with the magnitude of the weight. Also, be sure to use stud bolts (safety retention bolts) and other support tools for the work. Neglecting the above warning can lead to low back pain of the worker or injury due to dropping of the parts.
- If two or more people are to work together, be sure to clearly define the work procedures to
- share a common understanding among all workers before performing the work.
- Not only the work to turn each power supply ON/OFF or operate a lifting device, but also any type of work requiring qualification must be exclusively performed by qualified personnel.

 CAUTION

- When checking the operation data of units and executing other daily maintenance services, pay particular attention to avoid touching the area heated to a high temperature causing skin burns or inadvertently moving the handle of a valve leading to an erroneous operation.
- In the disassembly/inspection workplace, secure a sufficient space for temporary storage of the removed parts and tools, replacement parts, and for the disassembling work as well as safety passages, and then put up necessary off-limit signs.
- In the workplace, secure a sufficient space and refrain from putting tools directly on the floor or from haphazardly laying wires.
- Keep the floor clean all the time. Leaving the floor smeared with oil and the like causes it to be slippery and may result in the fall and injury of personnel. Thus, do not leave it but wipe it off right away.
- Make sure that the temperature of the high temperature sections such as head covers and discharge lines has been cooled down to normal ambient temperature, before working on them.
- When disassembling and reassembling the compressor, use the specified tools properly. Before starting to use those tools, gain the full understanding of their characteristics and the method for use.
- During the maintenance service, keep the tools clean all the time. Using those tools smeared with oil increases the risk of slip and fall, leading to an injury. Also during the service, there is a risk of foreign matters intruding inside the compressor to cause its damage.
- Parts are slippery with oil. Fully watch out for the risk of any object falling down. Pay attention to any parts falling down, which could lead to personal injury.

CAUTION

- Before disassembly, inspections, and handling of the compressor, sufficiently understand the disassembly and assembly procedures. This manual is not intended to provide complete disassembly and assembly procedures for the compressor. Instead, it describes only the important points in relation to the maintenance service of the compressor.
- If complete disassembly and assembly of the compressor are required, please contact your nearest sales office or service center of MAYEKAWA.
- When removing a part, be careful not to damage it.
- Place the removed parts on a clean workbench in an orderly manner.
- For cleaning parts, use kerosene and/or machine parts cleaner.
- Washed parts shall be dried by compressed air or wiped up using clean cloth. Do not use synthetic textiles or woolen textiles to prevent fibers from attaching the parts.
- When separating the assembled compressor casings, sometimes it is difficult to separate them due to the gasket stuck. In such a case, never hammer in a screw driver or flat chisel into the gap. Screw jack bolts using the screw holes to separate the casing each other. When some gap is observed between them, use a scraper to remove one side of the gasket from the surface.
- Removed bolts from each part should be classified into each used section to prevent confusion.

## 5.2 Maintenance and Inspection List

### 5.2.1 Daily Management

As daily management, check the items listed in Table 5-1 "Daily Inspection Items" and record the results.

Logging these operation data on a daily basis aid in finding out any abnormal conditions of the compressor. This is significantly effective in preventing compressor failures.

It is particularly important to check whether the temperature/pressure correlations related to the refrigerant evaporation and condensation is proper. This makes it possible to quickly find out problems in the compressor or the system.

If a failure or accident should occur in the compressor or the system, the operation logbook will help determine the cause and take prompt and proper actions.

Table 5-1 Daily Inspection Items

Inspection Items		Inspection Contents		Check Points and Actions
Compressor	Operating hours	hr	Total operating hours	<ul style="list-style-type: none"> <li>Judgment of periodic maintenance timing</li> </ul>
	Suction pressure	MPa Note 1	Difference from the set value of evaporation temperature equivalent pressure	<ul style="list-style-type: none"> <li>Contamination on the cooling pipe surface</li> <li>Temperature, flow rate, etc. of the object to be cooled</li> </ul>
	Intermediate pressure	MPa	Pressure difference from rated operation (normal value)	<ul style="list-style-type: none"> <li>If it is too high, check high-stage. If it is too low, check low-stage.</li> </ul>
	Discharge pressure	Mpa	Difference from cooling water temperature equivalent condensing pressure	<ul style="list-style-type: none"> <li>Contamination on condenser cooling pipes</li> <li>Non-condensable gases mixed into the system</li> <li>Quantity, temperature, etc. of cooling water</li> </ul>
	Oil supply pressure	MPa	Difference from discharge pressure	<ul style="list-style-type: none"> <li>Whether differential pressure is decreasing</li> <li>Operation with liquid flow-back</li> <li>Whether compressor parts are worn</li> </ul>
	Oil filter pressure loss	MPa	Pressure difference between oil filter inlet and outlet	<ul style="list-style-type: none"> <li>Contamination of lubricating oil</li> <li>Clogging of oil filter element</li> </ul>
	Suction temperature	°C	Whether within upper and lower limits	<ul style="list-style-type: none"> <li>Temperature, flow rate, etc. of the object to be cooled</li> </ul>
	Degree of superheat for suction	°C	Whether degree of superheat is proper	<ul style="list-style-type: none"> <li>Adjust expansion valve</li> <li>Insufficient refrigerant flow</li> </ul>
	Intermediate temperature	°C	Whether within upper and lower limits	<ul style="list-style-type: none"> <li>Adjust intermediate expansion valve</li> </ul>
	Discharge temperature	°C	Whether within upper limit	<ul style="list-style-type: none"> <li>Non-condensable gases mixed into the system</li> <li>Oil supply temperature, insufficient oil supply</li> <li>Compressor failure</li> </ul>

Inspection Items		Inspection Contents		Check Points and Actions
Compressor	Oil supply temperature	°C	Whether within upper and lower limits	• Contamination on cooling pipes of oil cooler
	Capacity control Indicated load	%	Whether operation is normal	• Damage to solenoid valve coil • Improper adjustment of manual control valve of electromagnetic assembly
	Leak from mechanical seal	ml	Leak per hour	• Mechanical seal failure
	Noise and vibration		Abnormal noise/vibration	• Compressor failure
Others	Motor current	A	Whether it is higher than the current at test run	• Compressor/Motor failure
	Oil level of oil separator	-	Oil level	• Oil loss • Replenish oil
	Fluid level in the receiver	-	Fluid level	• Replenish refrigerant
	Check for refrigerant leak	-	leak or not	• Inside the machine room and in the facility on the load side

**Note 1 :** Unless otherwise noted, the pressure unit MPa represents the gauge pressure in this manual.

### ■ Daily Maintenance Items

1. Lubricating oil level  
When the oil level in the oil separator reaches the lower limit, charge lubricating oil.
2. Replacing oil filter element  
When the differential pressure between the inlet and outlet ports of the oil filter exceeds 0.1 MPa, replace the filter element. During the period of initial operation, the pressure difference between the inlet and outlet ports of the oil filter can quickly become large
3. Cleaning of suction strainer  
When the compressor operating hours exceeds 500, check the suction strainer. If a temporary filter is installed for the initial stage of operation, remove it.  
At the beginning of the operation or after periodical check, the differential pressure between the front and back of the suction strainer may increase quickly. If the differential pressure becomes large, check and clean the suction strainer.
4. Lubricating oil leak rate from mechanical seal  
If much oil leaks from the mechanical seal, determine the leak rate per hour. The following table shows guidelines for allowable leak rate and the rate at which inspection must be done.  
If any problem (damage, etc.) is found in mechanical seal, replace the mechanical seal.

**Table 5-2 Guideline for Leak from Mechanical Seal**

	2016**C
Allowable leak rate	≤ 3 ml/hr
Rate at which inspection must be done	≥ 9 ml/hr

Note: The specifications above are just guidelines. They are not guaranteed values.

5. Contamination on the cooling water side of the cooling pipes of condenser and oil cooler  
Clogging and contamination of the cooling pipe is largely affected by the quality of cooling water. When the oil temperature and discharge pressure gradually rise during the initial stage of operation, inspect and clean the cooling water side of oil cooler and condenser even when the time has not yet come at which inspection must be done.

## 5.2.2 Periodic Inspection

Conduct inspection for the following items according to the specified intervals.

In addition, observe relevant laws and regulations on the inspections and recording of the results that are provided for other related items such as any safety devices (e.g. gas leak detectors), or other utility (gas/electricity) protection devices that constitute the cooling package unit together with the compressor.

**Table 5-3 Periodical Inspection Items**

Item	Inspection interval and Content	Remarks
Pressure gauges/ pressure sensors	Yearly inspection	
Thermometers/ temperature sensors	Yearly inspection	
Protection devices and safety valves	Yearly inspection	
Suction strainer	Inspect after 500 hours from the start of operation. Yearly inspection and cleaning	If the differential pressure between the front and back of the suction strainer increases, check and clean the suction strainer.
Lubricating oil	Analyze lubricating oil after 500 hours from the start of operation. Analyze oil every 6 months.	Replace the oil if the analysis result does not satisfy the control criteria given in Section 4.1.5 "Lubricating oil Management Criteria".
Oil filter element	Yearly replacement	Replace the filter element if the differential pressure between the inlet and outlet ports of the oil filter exceeds 0.1 MPa.
Cooling water side of oil cooler	Yearly inspection	Clean if excessively contaminated.
Cooling water side of condenser	Yearly inspection	Clean if excessively contaminated.
Mechanical seal	Inspection every year or every 8000 hours of operation <b>Note*</b>	To be replaced if any abnormality is found If it is difficult to stop equipment except for scheduled inspections, replace the part at each inspection.
Coupling	Inspection every year or every 8000 hours of operation <b>Note*</b>	

**Note\*:** The inspection shall be performed according to the operating period or operating hours, whichever comes first.

### 5.2.3 Guidelines for the Timing of Compressor Overhaul

The compressor overhaul interval is largely affected by the compressor operating conditions, type and status of refrigerant and oil, and the system/equipment in which the compressor is operated.

The table below shows the recommended interval of overhaul, as a guideline.

**Table 5-4 Guidelines for the Timing of Overhaul Based on the Conditions of Use  
(standard package)**

Category of operating condition	Application example	Guideline for the overhaul timing
Relatively stable operating condition	Cold storage and refrigeration	Every 5 years or 40,000 operating hours
Relatively variable operating condition	Ice maker/chiller	Every 4 years or 30,000 operating hours
Frequently started/stopped, and relatively variable operating conditions	Heat pump	Every 3 years or 20,000 operating hours

Note 1: The above guidelines are only applicable when the compressor is operated within the operation limits specified separately.

(Refer to Section 2.3.2 "Operation Limits" in this manual.)

Note 2: The above guidelines are only applicable when the compressor undergoes daily and periodical inspections specified separately.

(Refer to Section 5.2.1 "Daily Management" in this manual.)

Note 3: Inspect the compressor at the intervals of specified period or operating hours, whichever comes first.

Note 4: The above guidelines do not constitute any warranty.

## 5.3 Compressor Disassembly Preparation

Although screw compressors are very reliable machines it is still necessary to disassemble and inspect parts after a certain period of operation.

This chapter 5 describes the essential points of disassembly methods, where to inspect on parts, and reassembly procedure of the compound 2-stage screw compressor 2016\*\*C.

In principle, overhauling of the screw compressor that require complete disassembly should be performed in the maintenance factory.

If you must do the overhaul work at the installation site due to unavoidable reasons, use the methods described in the following paragraphs.

However, please note that regular overhaul work requires removal of the compressor from the base frame. And then, the compressor should be placed on a work bench which has properly size area to disassembling the compressor.

When moving the compressor from the unit base to the workbench, be sure to follow the instructions given in Chapter 3, Section 3.1 "General Installation Precautions" and Section 3.2.3 "Transportation" in this manual.

Note that some parts name given in the text of this manual is followed by a number enclosed in square brackets [ ], which indicates the part identification number given in assembly sectional views and/or parts configuration table.

### 5.3.1 Disassembly Tools and Work Place

Prepare necessary disassembly tools for the compressor by referring to Section 7.5 "Disassembly Tools" in this manual Chapter 7.

In addition, prepare other necessary tools and materials including general hand tools, GC (green carbonite) grinding stones, sandpapers of #80 to #100, about #400 to #800 sandpapers, parts cleaner, lubricating oil, oilcan, empty can to receive drain oil, waste, etc.

If the overhaul work is to be done with the compressor removed from the installation base, prepare the work bench whose size is at least around 1.5 times the length and the width of the compressor..

In addition, a special stand for the compressor is required in order to safely perform the removal/fastening of bolts and plugs on the bottom side of the compressor. Refer to Section 5.3.5 of this chapter.

To the extent possible, choose a dry and clean workplace free from sand or dust. Note that a sufficient space is required around the compressor. In addition, it is necessary a temporary storage place for disassembled parts .

### 5.3.2 Replacement Parts

Prepare **MYCOM** genuine replacement parts.

Parts listed in Table 5-5, we recommend to be replaced on the occasion of each compressor overhaul.

When ordering any part, inform its (a) model name, (b) serial number, (c) part name, (d) code No. and (e) quantity required to our sales offices or service centers. Especially when the (b) serial number of the compressor is not identified, it will be difficult to decide the required parts because we can not specify the design and manufacturing specifications. So, make sure to inform the (b) serial number to us.

Table 5-5 Replacement Parts of 2016\*\*C Overhauling

P/N	Part Name	Code No.	Remarks	Q'ty.
6-1	Gasket, Suction Cover (1)	CS00600-200N		1
6-2	Gasket, Suction Cover (2)	CS00600-160N		1
9	O-ring JIS B 2401 P30	PA11-030		1
12-1	Gasket, Bearing Head (1)	CS01200-200N		1
12-2	Gasket, Bearing Head (2)	CS01200-160N		1
17-1	Gasket, Bearing Cover (1)	CS01700-2016C1N		1
17-2	Gasket, Bearing Cover (2)	CS01700-2016C2N		1
23	Gasket, Balance Piston Cover	CS02300-160N		1
27-1	Main Bearing (1) with O-ring	CS0270-ERT		2
27-2	Main Bearing (2) with O-ring	CS0270-DRT		2
28-1	Side Bearing (1) with O-ring	CS0280-ERT		2
28-2	Side Bearing (2) with O-ring	CS0280-DRT		2
30	Balance Piston	CS03000-160	To be replaced if any abnormality is found.	1
33	Balance Piston Sleeve	CS03300-160		1
35	O-ring JIS B 2401 G95	PA12-095		1
38-1	Thrust Bearing (1)	CS03800-200P		2
38-2	Thrust Bearing (2)	CS03800-160P		2
39-1	Lock Nut (1) AN13	NG31-013	To be replaced if any abnormality is found.	2
39-2	Lock Nut (2) AN12	NG31-012		2
40-1	Lock Washer (1) AW13	NG32-013		2
40-2	Lock Washer (2) AW12	NG32-012		2
49	O-ring JIS B 2401 G115	PA12-115		1
50	Oil Seal	CS05010-200VD		1
52	Gasket, Seal Cover	CS05200-200N		1
59	O-ring JIS B 2401 P20	PA11-020		1
63	O-ring JIS B 2401 G125	PA12-125		2
65	O-ring JIS B 2401 P100	PA11-100		2
66	Cap Seal BE-100	CS06600-160		2
68-1	Guide Pin (1)	NE2505-012	To be replaced if any abnormality is found.	1
68-2	Guide Pin (2)	NE2503-008		1
69-1	Lock Nut (1) AN07	NG31-007	To be replaced if any abnormality is found.	1
69-2	Lock Nut (2) AN05	NG31-005		1
70-1	Lock Washer (1) AW07	NG32-007		1
70-2	Lock Washer (2) AW05	NG32-005		1
73-1	O-ring JIS B 2401 G30	PA12-030		1
73-2	O-ring JIS B 2401 P21	PA11-021		1
75	O-ring JIS B 2401 G110	PA12-110		2
78	Ball Bearing, Indicator Cam #6000	CS07800-200		2
79	Snap ring C type External S10	NG12-010		2
82	V-ring, Indicator Cam VH10 NBR	CS08200-200B		2
86	O-ring JIS B 2401 P21	PA11-021		1
89-1	O-ring JIS B 2401 P20	PA11-020		2



P/N	Part Name	Code No.	Remarks	Q'ty.
89-2	O-ring, Guide Block Stem (1)	PA11-016	JIS B 2401 P16	2
93-1	Gasket, Suction Flange (1)	CS71200-150N	JIS 20K 150A(6")	1
93-2	Gasket, Suction Flange (2)	CS71200-100N	JIS 20K 100A(4")	1
96-1	Gasket, Discharge Flange (1)	CS71200-100N	JIS 20K 100A(4")	1
96-2	Gasket, Discharge Flange (2)	CS71200-080N	JIS 20K 80A(3")	1
100	Mechanical Seal Assembly BBS-E	CS10002-200EBS		1
125-1	Micro-switch Set(1)	CS1259-C	To be replaced if any abnormality is found.	1
125-2	Micro-switch (2)	CS12500-200		2
129	Potentiometer (1) 1612K with Wire	CS1299-J	To be replaced if any abnormality is found.	1
129	Potentiometer (2) 200-1k with Wire	CS1299-E10		1
	Gear Coupling Assembly (Current Type)	CS1519-K	To be replaced if any abnormality is found.	1
159	Knurled Cup Point Socket Set Screw	NA83608-015	To be replaced if any abnormality is found.	1
160	Lock Nut AN10, Drive Hub	NG31-010	To be replaced if any abnormality is found.	1
161	Lock Washer AW10	NG32-010		1
163	O-ring JIS B 2401 G25	PA12-025		1
165	O-ring JIS B 2401 G25	PA12-025		1
197	O-ring JIS B 2401 P40	PA11-040		1
202	Bevel Gear (2) 1612LSC(φ6)	CS20100-1612C6	To be replaced if any abnormality is found.	2
216-1	Gasket, Lubricating Oil Inlet Flange (1)	CS71200-025N	JIS 20K 25A (1")	1
216-2	Gasket, Lubricating Oil Inlet Flange (2)	CS71200-020N	JIS 20K 20A (3/4")	1
219	Gasket, Oil Injection Inlet Flange	CS71200-015N	JIS 20K 15A (1/2")	1
237-1	Torsional Slip Washer (1)	CS23700-200		2
237-2	Torsional Slip Washer (2)	CS23700-160		2
421	O-ring JIS B 2401 G30	PA12-030		1(*SC)
421	O-ring JIS B 2401 P30	PA11-030		2(LLC,LMC) 1(MMC)
432-1	O-ring (Old JIS W 1516 G22)	PA62-022	AS568A-244	4
432-2	O-ring JIS B 2401 G85	PA12-085		4
433-1	O-ring (Old JIS W 1516 G22)	PA62-022	AS568A-244	4
433-2	O-ring JIS B 2401 G85	PA12-085		4
528	Oil Seal Sleeve with O-ring	CS52809-200VD		1
702	O-ring JIS B 2401 G100	PA12-100		1(MMC,MSC)
744	O-ring JIS B 2401 G60	PA12-060		1

**【POINT】**

In case of replacing the main/side bearings of No.27 and No.28, it is not necessary to prepare the O-rings of No.432 and No.433 because the main/side bearings have the O-rings.

**CAUTION**

- The part code of the O-ring is the one assigned to NBR which is standard material. When the material of the O-ring is other than NBR, a different part code is used for each material.  
If you are using O-rings made from other than the standard material, please contact us when placing an order.

### 5.3.3 Refrigerant Gas Recovery

At the time the compressor operation is stopped, the pressure inside the compressor is still high. As such, it is necessary to lower the pressure down to the atmospheric pressure before starting the disassembly process. To do this, there are the following methods for example. Perform your recovery work in an appropriate manner considering site conditions, requirements of regulatory laws and regulations.

- By using the bypass valve, release the high pressure gas in the package unit to the low pressure side.
- If there is another compressor unit to which a permanent bypass line is connected, operate the other compressor and lower the pressure through the bypass line.
- Operate the refrigerating system, and close the fluid supply master valve to turn the gas into liquid, and recover the liquid at the receiver.
- By using a refrigerant recovery machine, recover the liquefied refrigerant in the receiver.

In using either method, prepare a working flow sheet of the system beforehand. Check the valves to be controlled during the recovery work, according to the method to be used, by comparing them with the ones in the flow sheet, and clearly note the valves to be operated, other connected devices, and tubes on the flow sheet.

Two flow sheets must be prepared: one at the foreman and the other for posting in the workplace.

In addition, prepare a work procedure document for the refrigerant recovery work to reflect the actual conditions of the workplace, and sufficiently share the work details among all the coworkers through checking and confirmation before actually starting the work.

The gas mask and other protective gears required at each stage of refrigerant recovery work must be prepared before starting the work.

#### WARNING

- Before the work, be sure to check and communicate the work details and procedure among all coworkers, and carry out hazard prediction activities based on the information shared. Neglecting to do this will increase the risk of on-the-job accidents and injuries to a considerable level.
- After closing (opening) a valve for work, conduct lockout/tagout to prevent it from being handled accidentally during work.

### 5.3.4 Removing Parts Connected to the Unit



- **If refrigerant gas or a mixture of refrigerant and oil remains in the compressor, refrigerant gas may blow off when the closed circuit is opened. This may result in injury such as frostbite or loss of vision. Be sure to confirm that there is no residual pressure before opening any pipe connections.**

When removing the compressor from the mounting base frame, the following parts must be disconnected beforehand:

- (1) Coupling that is connecting the compressor and driving machine;
- (2) Compressor's suction pipe flange and discharge pipe flange (if the suction strainer is connected directly with the compressor, remove the strainer, too), and the intermediate pipe connecting low-stage discharge port and high-stage suction port;
- (3) Compressor's lubrication piping  
(journal lubrication (2 sets), oil injection (1 set) and capacity control loading/unloading (2 sets for each));
- (4) Electric wiring for operating capacity control  
(Depending on the situation of the workplace, unloader indicator assembly may be removed, with the wiring left as it is. Refer to Section 5.4.2. and Section 5.5.15 in this chapter);
- (5) Bolts for mounting the compressor (leg bolts); and

---

#### 【POINT】

When removing oil lines from the compressor, there is possibility of gas and oil blowing out caused by residual pressure. And any residual oil in the pipe will flow out. To be prepared for this, either check the amount of oil outflow by slightly loosening the pipe joint or drain the oil from the oil temperature gauge at the supply header before removing the pipe.

Work carefully in particular when disassembling the unloader cylinder block since there is residual pressure and oil fills in the unloader cylinder. Moreover, prepare a larger volume container than the unloader cylinder volume to receive oil flowing out.

For easy reconnection, disconnected electric wires should be properly marked for identification. Any wrong reconnection may result in a startup failure or inability to operate the capacity control mechanism.

---

### 5.3.5 Compressor Removing and Lifting



- The work to lift up or move the compressor must be performed by a qualified operator.
- Make sure that the lifting equipment and wires have sufficient load capacity for the compressor before starting the compressor lifting work.
- Never try to perform disassembly or assembly while the compressor is lifted in the air.

#### 【POINT】

As the suction pipe is located immediately above the compressor, lift up or partially remove the pipe such that it will not interfere with the lifting device.

For the lifting positions of the compressor, refer to Photo 002 or Figure 3-1 in page 3-3 of Chapter 3 in this manual, and/or Photo 003 shown below.

If the planned overhaul work includes separation between low-stage and high-stage blocks of the compressor, place the compressor on a special stand as shown in Photo 004 and then remove eight or more hexagon head cap screws around the bottom flange part. **Never try to remove these bolts while the compressor is lifted in the air.** Note that these bolts cannot be removed once the compressor is placed on the work bench.



Photo 003 Lifting the Compressor



Photo 004 Lower-side Bolts for  
Fastening Rotor Casing

### 5.3.6 Removing Oil from Inside the Compressor

Remove oil in advance, since a large quantity of oil remains inside the compressor.

There is plug [10] under suction covers [5-1] [5-2] and plug [15] under bearing head [11-1].

Most of the oil will flow out of these plug holes. Remove the remaining oil as it appears, while disassembling the compressor on the work bench.

Oil mainly resides inside a) unloader cylinders [60-1] [60-2], b) balance piston cover [22], c) seal cover [51] and d) suction covers [5-1] [5-2].

Prepare a receiving tray and waste cloth for oil that will spill during disassembly.

## 5.4 Disassembly and Inspection

Generally compressors are disassembled in the order shown in Figure 5-1 Illustrated Disassembly Sequence but the order in the figure is just an example and the actual order may differ according to individual situations.

For instance when overhauling it is no problem to start separation of high-stage part from low-stage part after removing the compressor from the unit frame and putting it on the work bench prepared beforehand.

In addition it is often the case that the disassembly of unloader cover/unloader cylinder part from mechanical seal part is performed in the reverse order of shown in the Figure 5-1.

Shown in the steps in the Figure 5-1, ① through ⑤, ⑩ and ⑪, you can disassemble the compressor with the compressor attached on its frame.

When conducting steps ⑦ through ⑳, perform each step after removing the compressor and placing it on the work bench.

When conducting steps ⑦ through ⑳, the compressor should be removed from its frame and placed on a work bench prepared in advance.

When disassembling high-stage or low-stage side only, start from step ⑦ and disassemble necessary parts only.

Parts which have no problem should be left as they are. Do not disassemble such parts unless during periodical inspection.

Since it is difficult to completely eliminate the risks of performing inaccurate work at the field, disassemble the minimum required parts only.

**Table 5-6 Disassembly Sequence of 2016\*\*C (example)**

Part to Be Disassembled		Disassembly Sequence (Refer to Figure 5-1)
(1)	Shaft seal block	①—②
(2)	Unloader indicator	③
(3)	Unloader cylinder cover	③—④
(4)	Unloader piston and unloader cylinder	④
(5)	Bearing cover	⑤
(7)	Separating high-stage and low-stage.	⑦
<u>High-stage parts</u>		
(8)	Gear coupling	⑦—⑧
(9)	Thrust bearing	⑦—⑧—⑨
(10)	Balance piston cover	⑩—⑪
(11)	Balance piston	⑩—⑪
(12)	Suction cover and side bearings	⑩—⑪—⑫
(13)	Rotors and main rotor casing	⑬—⑭
(14)	Bearing head and main bearing	⑭
<u>Low-stage parts</u>		
(15)	Bearing head, thrust bearings, etc.	⑮
(16)	Gear coupling	⑯
(17)	Suction cover and side bearings	⑰
(18)	Rotors and main rotor casing	⑱—⑲
(19)	Bearing head and main bearings	⑲
(20)	Unloader slide valve and guide block	⑲

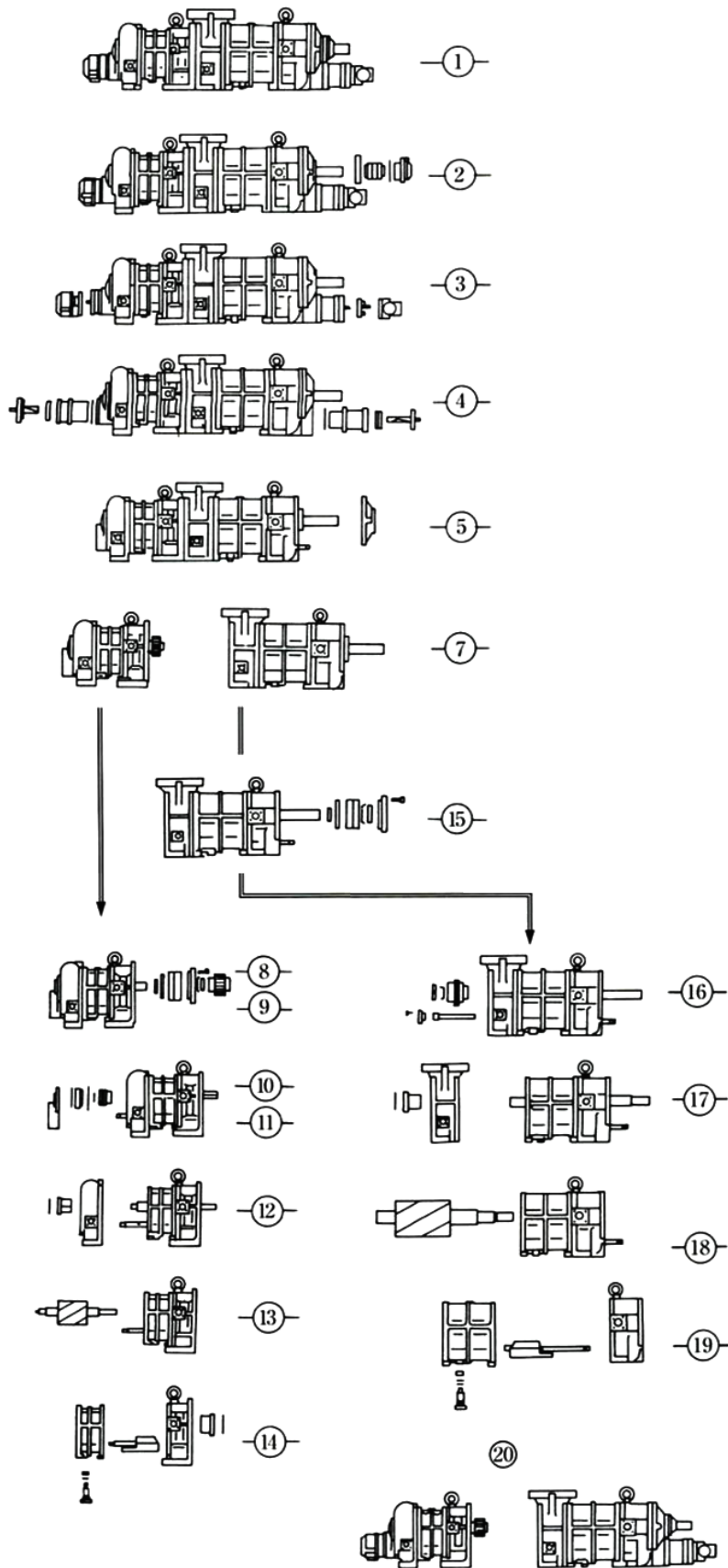

Figure 5-1 Illustrated Disassembly Sequence (example)

## 5.4.1 Shaft Seal Block

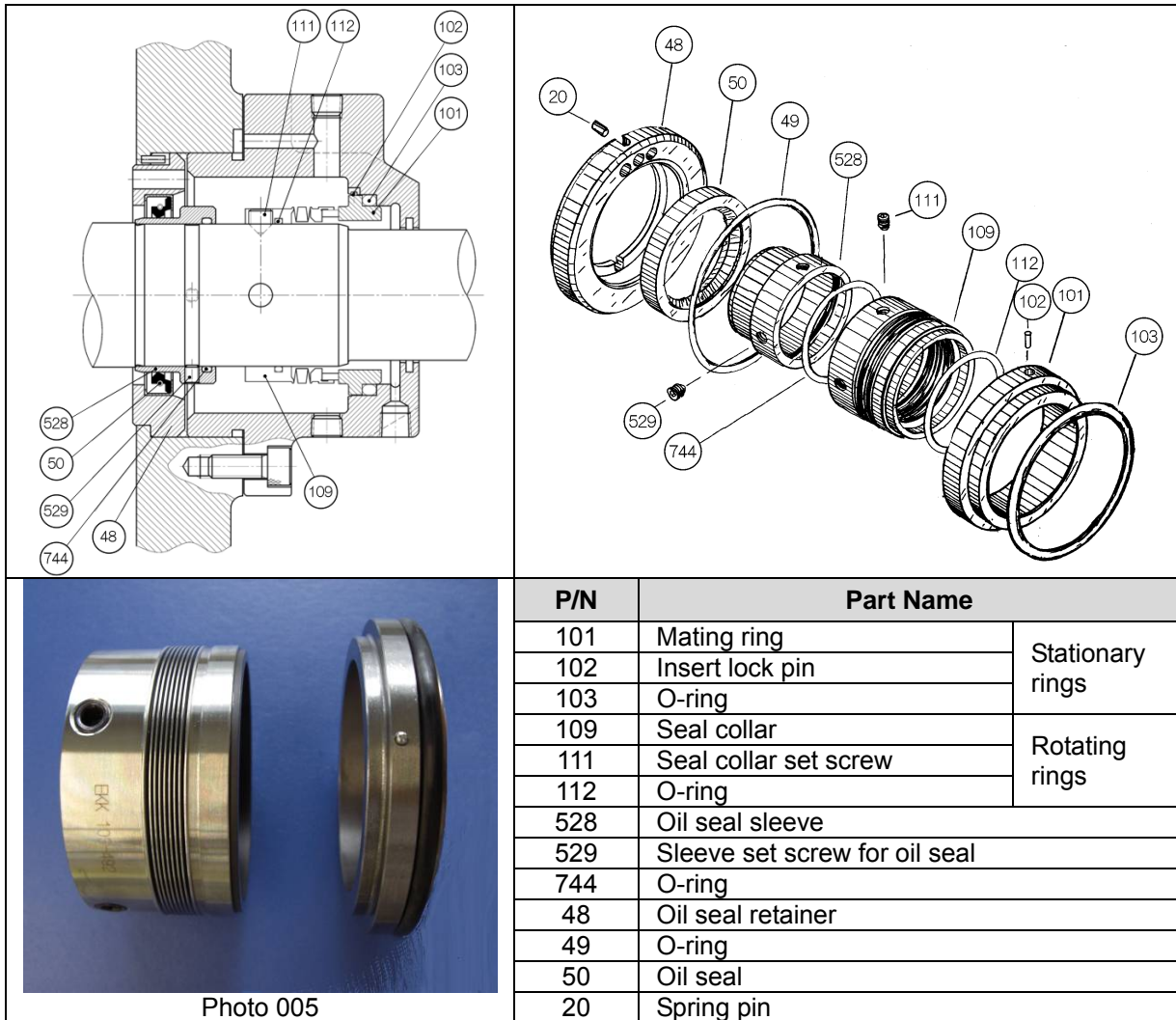

Figure 5-2 Details of BBSE Type Mechanical Seal Assembly and Related Parts

### 5.4.1.1 Disassembly

- Of the eight hexagon socket head cap screws [53] securing the seal cover [51], remove six screws leaving two diagonally opposite screws.
- Loosen the remaining two screws alternately and evenly, a little at a time. After loosened to some extent, the seal cover of the mechanical seal will be raised slightly by the force of the inside spring, creating a gap under the cover. The gap will not be created if the gasket is sticking to both surfaces. In this case, free the cover by screwing the M8 eye bolts into the jacking screw holes in the seal cover to separate it.
- Use a container to catch the oil that will flow out through the gap.
- Pull out the seal cover, while keeping it parallel with the shaft (rotor shaft). The mating ring is attached inside the seal cover by using an O-ring. Be careful not to let the mating ring and the shaft damaged by contact.
- Remove the O-ring [49] from between the seal cover and oil seal retainer [48].

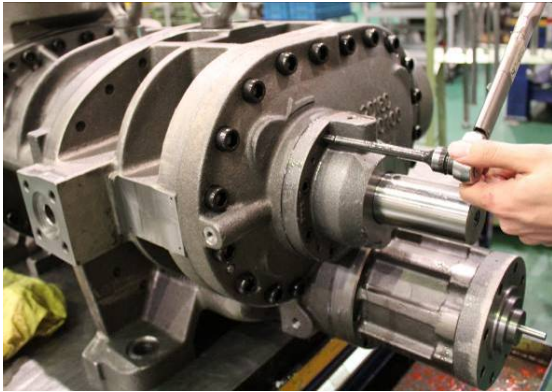

Photo 006 Removing Seal Cover

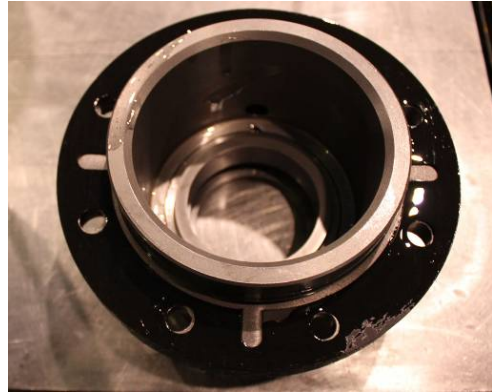

Photo 007 Seal Cover and Mating Ring

- f) After removing the seal cover, wipe clean and inspect the shaft surface. If there are scratches, use fine sandpaper to smooth them over. This is done to prevent damage to the internal O-ring when pulling out the mechanical seal.
- g) Loosen the set screws [111] securing the seal collar [109] by turning them approximately three times (Photo 008).  
Do not remove the set screws completely, but leave them so that their ends are below the surface of the seal collar. These screws are located in two places 90 degrees apart from each other.

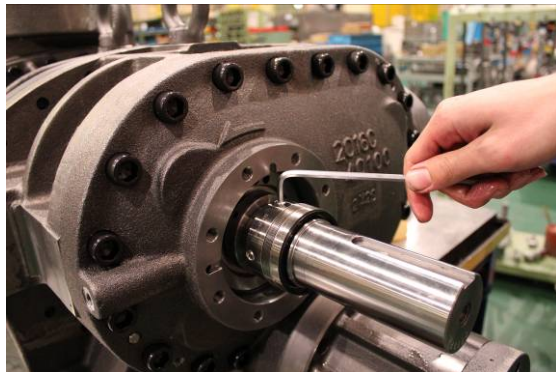

Photo 008 Loosening the Seal Collar Set Screws



Photo 009 Oil Seal Retainer

- h) Pull out the seal collar with your fingers. While pulling out, make sure that the ends of the set screws do not touch the shaft surface. Axial-direction scratches on the shaft can cause leaks.
- i) By removing the two set screws [529], pull out the oil seal sleeve [528].
- j) Screw two M8 eye bolts into the screw holes in the oil seal retainer [48] and pull out the oil seal retainer while keeping it at a right angle against the shaft.
- k) Remove the oil seal [50] that is attached into the oil seal retainer.

### 5.4.1.2 Inspection

- a) Mechanical seal should be replaced if any defect is found during inspection. Actually, however, it is sometimes difficult to find out defects on the sliding surface only through visual inspection. In such circumstances, MAYEKAWA recommends to replace it with a new one in the same manner as with O-rings or gaskets.

Also, if it is difficult to stop the compressor operation except for scheduled inspections, we recommend to replace the mechanical seal assembly with a new one at every inspection of this block.



The contact between the sliding surfaces of the mating ring and seal collar must be checked even when replacing the seal. If there are obvious traces of uneven contact or damage, find out the cause (degradation over time, problems such as heating operation, etc.) and take necessary actions.

- b) Replace the O-rings every time the mechanical seal assembly is inspected because they normally swell and deform over time.

A total of four O-rings are used for the sealing section. They are located between the seal cover and oil seal retainer [49]; between the mating ring and seal cover [103]; between the seal collar and shaft [112]; and between the shaft and oil seal sleeve [744].

- c) Inspect the oil seal sleeve for wear in its section rubbing against the oil seal lip.

If wear is evident, replace both the oil seal [50] and oil seal sleeve [528] with new parts. Since the oil seal is made of a special material, only a genuine oil seal must be used for replacement.

<About the O-rings attached to oil seal sleeve [744]>

In the design modification applied in March, 2010, O-ring [744] is attached to the inner diameter of the oil seal sleeve.

- d) Replace the seal cover gasket with a new one.



Photo 010 Oil Seal Retainer and Oil Seal Sleeve attached with O-ring

## 5.4.2 Unloader Indicator

As the 2016\*\*C model has a capacity control mechanism also on the high-stage, it has two separately-placed indicators. Normally, the low-stage capacity control only is used during operation. The high-stage capacity control mechanism is used to reduce the startup load.

As various control methods are employed depending on the system, refer to the separate electrical control schematic diagram (provided for each plant).

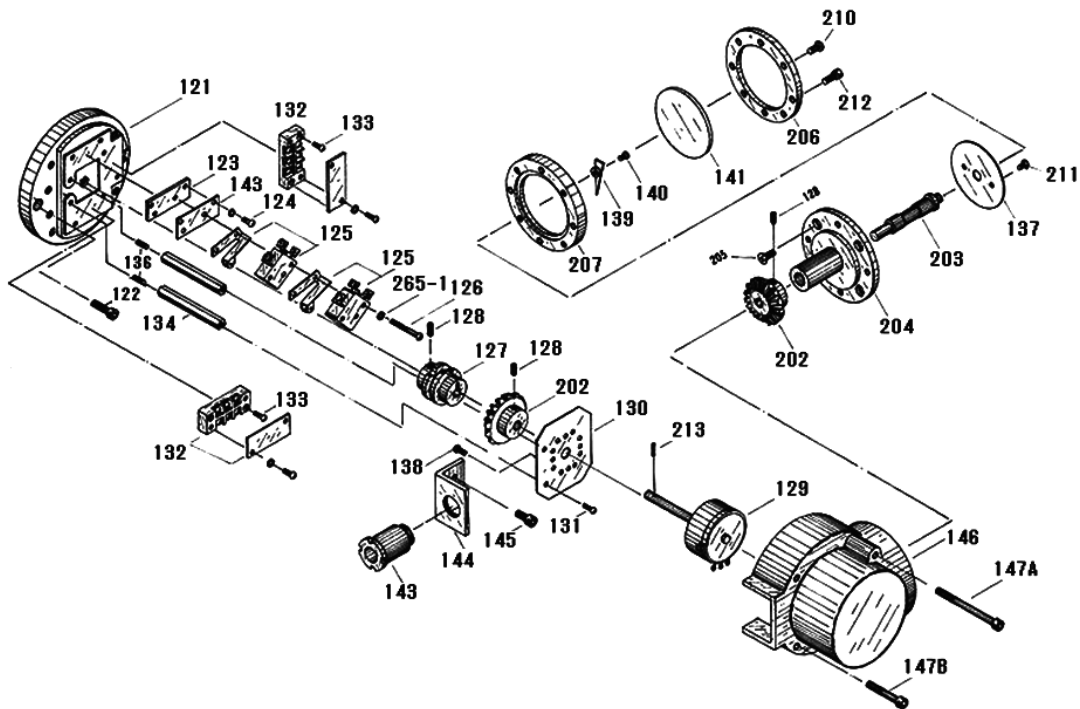

Figure 5-3 2016\*\*C Low-stage Unloader Indicator Block (same as 1612C Low-stage)

### 5.4.2.1 Disassembly

#### ■ When removing wiring only

When removing the compressor, the wiring of the unloader indicator has to be pulled out. As the indicator has a terminal board for wiring, remove the cover from the indicator. Follow the procedure below. After the wiring is removed, attach the cover again for protection.

#### [Low-stage]

- Loosen the hexagon socket head cap screws [212] fastening the indicator glass [141]. Do not by mistake loosen the crosshead screw [210] on the same surface. Remove assemblies [141], [202 to 207], [210] and [211].
- Remove hexagon socket head cap screws [147A] [147B] (two each) that fasten the indicator cover [146]. Then the cover gets removable.
- There is a terminal block. Remove the plastic plate on the surface, and loosen the screws.

#### [High-stage]

- Remove three hexagon socket head cap screws [147] that fasten the indicator cover [146]. Then the cover gets removable.
- The indicator cover comes off with glass [141] and indicator glass spacer [142] attached. The glass and the spacer are pasted together, however, take care not to drop them as they may come apart.
- Remove the wiring.

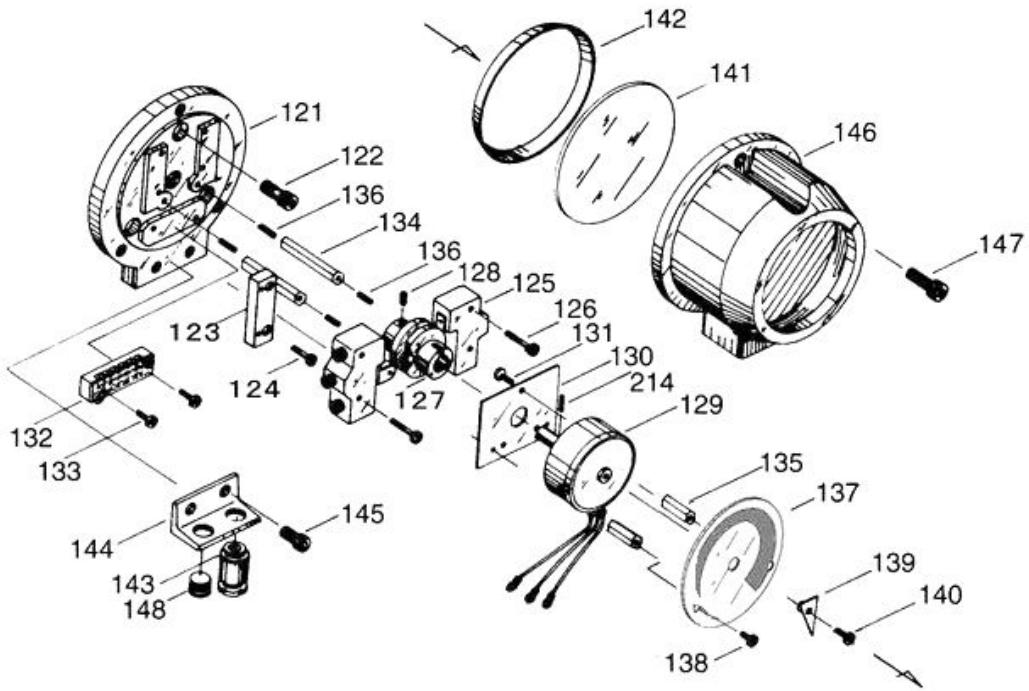

Figure 5-4 2016\*\*C High-stage Unloader Indicator (Standard type, High-stage Dial Plate)

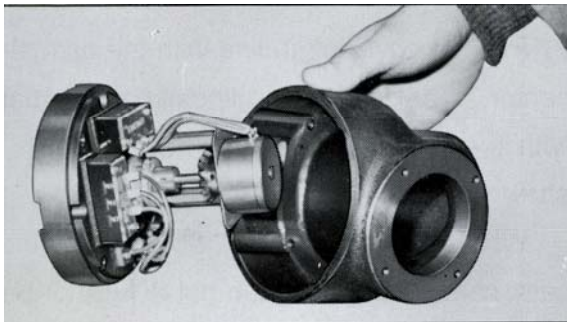

Photo 011 Removing Low-stage Indicator Cover

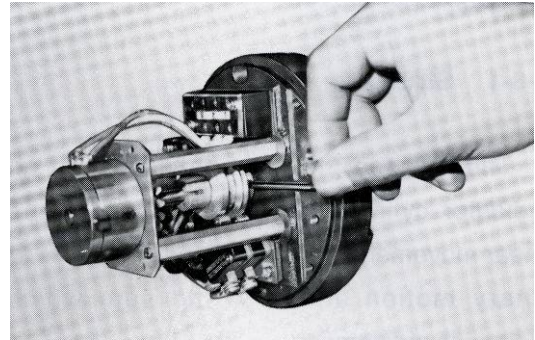

Photo 012 Loosening Low-stage Micro-switch Cam Set Screw

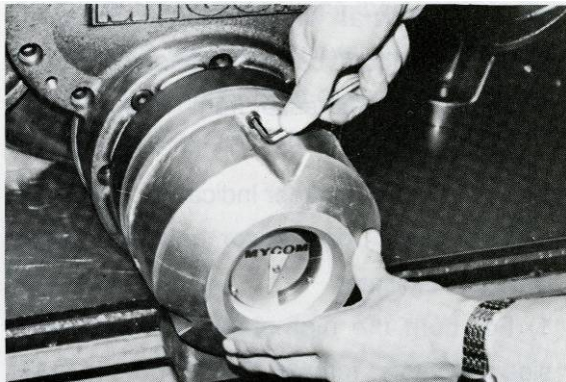

Photo 013 Removing High-stage Indicator Cover

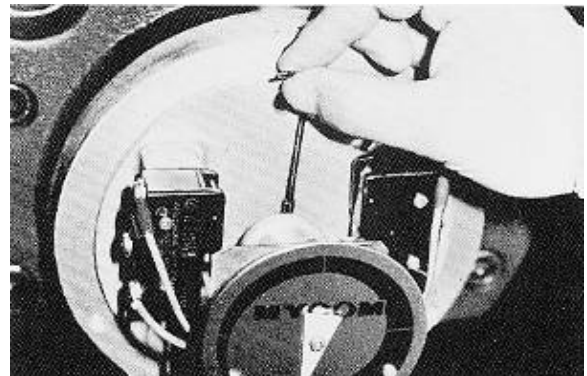

Photo 014 Loosening High-stage Micro-switch Cam Set Screw

■ **When removing entire unloader indicator assembly, with the wiring left as it is**

The indicator is an assembly. Unless it needs to be disassembled, remove it as a assembly unit and do not disassemble it into smaller parts.

**[High-stage/Low-stage]**

- a) As a result of the disassembly process conducted above, (i) the internal potentiometer, (ii) micro-switch and (iii) micro-switch base plate [121] attached with micro-switch cam get removable.
- b) Remove hexagon socket head cap screws [122].
- c) Loosen the micro-switch cam set screw [128].
- d) Now, the assembly can be pulled out as it is if pulled out in the axial direction.

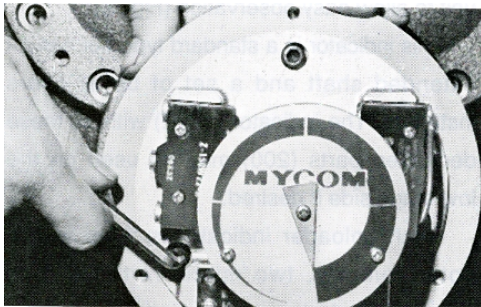

Photo 015 Loosening the Screws Securing High-stage

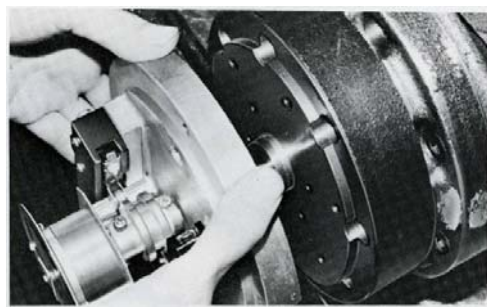

Photo 016 Removing High-stage Indicator Micro-switch Base Plate

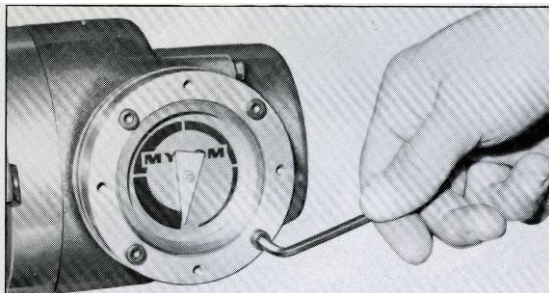

Photo 017 Removing Low-stage Indicator

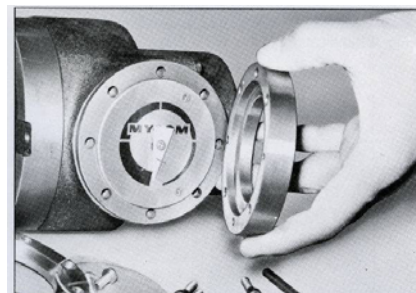

Photo 018 Removing Low-stage Indicator Cover

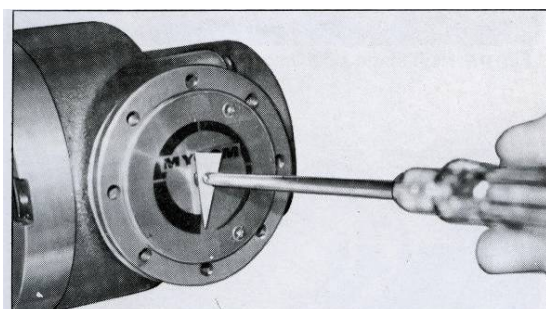

Photo 019 Removing Low-stage Indicator Pointer

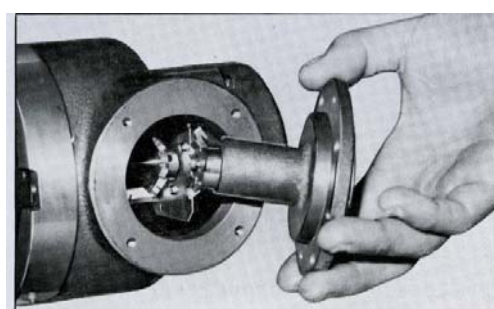

Photo 020 Low-stage Indicator Inside

### 5.4.2.2 Inspection

Inspection and adjustment of the unloader indicator is often done after its removal as part of indicator assembly. The inspection and adjustment is done after the compressor, which was disassembled and inspected, is reassembled and restored to the package unit frame. So, for information on inspection, refer to Section 5.5.14 "Unloader Indicator" in this chapter.

## 5.4.3 Unloader Cover

The unloader cover [74-1] [74-2] is mounted with the indicator cam [77-1] [77-2], which converts the Indicator Cam , and their mounting parts.

### 5.4.3.1 Disassembly



Photo 021 Loosening Bolts of Unloader Cover



Photo 022 Removing Unloader Cover

- a) Remove the hexagon socket head cap screws [76] used to attach the unloader cover.
- b) The indicator cam [77], which is attached to the unloader cover, is fit to the inner side of the unloader push rod [67] which is inside the unloader cylinder. The guide pin [68] at the tip end of the push rod is engaged with the spiral groove of the indicator cam. So the unloader cover can be pulled out straight as it is (Photo 022).  
If the unloader cover should be bent obliquely, the shaft of the indicator cam will also be bent. So take care.

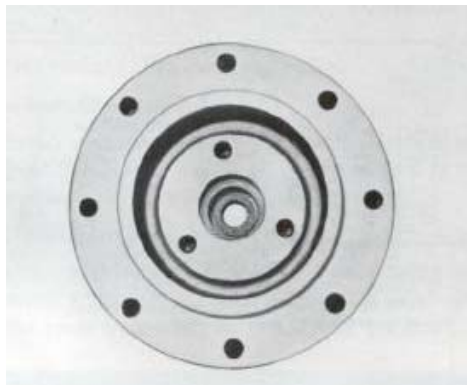

Photo 023 Main Body of Unloader Cover



Photo 024 Sealed Portion of Indicator Cam

- c) If the indicator cam does not move properly, check the spiral groove of the indicator cam, bearing and guide pin. Disassembly sequence is as shown below.
  - c-1) The bearing gland [80] that holds the indicator cam is secured to the cylinder side of the unloader cover. Remove the three hexagon socket head cap screws [81] that are securing the bearing gland.
  - c-2) Now, the indicator cam can be pulled out as it is, together (attached to its shaft) with its ball bearing [78] and external snap ring [79] securing the bearing.
  - c-3) The spring retainer [84], spring [83] and V-rings [82] are attached, in this order, to the inside of the unloader cylinder cover.  
The outer diameter of the Teflon V-rings is attached tightly to the holes of the unloader cover. These V-rings, once removed, cannot be reused because their tongue portion gets damaged. So be careful.



Photo 025 V-ring (Black part is NBR/FKM.)

### 5.4.3.2 Inspection

- Check the packing portion of the indicator cam shaft for any flaw. If the refrigerant leaks without any flaw observed in this part, it should be due to a defect of the V-ring or installing the V-ring without sufficient oil. In this case, replace the V-ring.
- Check the spiral groove of the indicator cam. If defect such as damage or wear is found, replace it with a new one.

## 5.4.4 Unloader Piston and Unloader Cylinder

### 5.4.4.1 Disassembly

- Pull out the unloader piston [64] to the utmost front position.
- Then, unbend the rotation stopper tooth of the lock washer [70] and loosen the lock nut [69].
- As the unloader piston has two screw holes, screw in two M8 eye bolts and pull out the piston with the eye bolts.
- The low-stage unloader cylinder [60-1] is, together with the bearing cover [16], attached to the low-stage bearing head [11-1] by using eight long bolts [62-1]. Remove those bolts [62-1], and pull out the unloader cylinder.



Photo 026 Unbending the Lock Washer Tooth



Photo 027 Removing Lock Nut

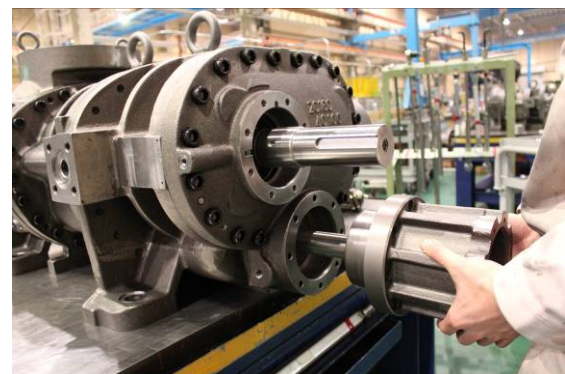

Photo 028 Removing Low-stage Unloader Cylinder

- e) The high-stage unloader cylinder [60-2] is, fastened by using two hexagon socket head cap screws [61] and six hexagon socket head cap screws [62-2]. Pull out the unloader cylinder in the same way as described in b) above. If, after disassembly of the cylinder portion, further process of disassembly has to be done, leave the two screws [61] fastened as they are and remove the bolts [62-2] and bolts [24] that fasten the balance piston cover, so that the unloader cylinder can be removed as a unit, combined with the balance piston cover. At this moment, there is oil accumulated at the balance piston and side bearings. So pay attention to the oil that will flow out when removing the balance piston cover. When the gasket [23] is stuck, remove it by tapping the balance piston cover with a hammer.



Photo 029 Removing High-stage Unloader Cylinder

#### 5.4.4.2 Inspection

- a) Be sure to replace the cap seal [66], which is attached to the outer circumference of the unloader piston [64], as well as the O-ring [65].
- b) The unloader cylinder often has damage or oil refuse stuck to its inner surface. Clean it thoroughly, and smoothen its surface by using fine sandpaper (#400 or finer).



Photo 030 Removing the Cap Seal of the Unloader Piston

## 5.4.5 Bearing Cover

The bearing cover [16] should be removed when pulling out the low-stage thrust bearings or rotors for inspection.

### 5.4.5.1 Disassembly

- a) Remove all the hexagon socket head cap screws [18-1]. The bearing cover remains attached to the bearing head [11-1] with alignment pins [19-1].
- b) Screw holes are provided in symmetric positions. Screw the two bolts that have been removed [18-1] into the right and left holes. This will cause the bearing cover to separate from the bearing head. When a small gap is created, peel up one side of the gasket [17-1] by using a scraper
- c) Screw the bolts further, until the cover comes off the alignment pins.

#### CAUTION

- **At this time, be sure to support the bearing cover. Otherwise, it may fall over or fall down, causing the shaft (rotor shaft) to get damaged. Protect in advance the shaft with a cloth, or the like.**



Photo 031 Removing Bearing Cover



Photo 032 After the Bearing Cover is Removed



## 5.4.6 Separating High-stage and Low-stage

Separate the high-stage and low-stage when pulling out the high-stage thrust bearings or rotors of each stage. Structurally, they can be separated at the initial step of disassembly.

### 5.4.6.1 Disassembly

- a) As explained in Section 5.3.5 of this chapter, put the compressor on a special table and remove the bolts from the lower side. Then, remove the remaining hexagon socket head cap screws [18-2].  
At this moment, the high-stage of the compressor is spaced apart the work bench. Brace the high-stage with a rectangular piece of wood or the like to prevent it from falling when disassembled. As the screws [18-2] of the 2016\*\*C model are 5 mm longer than other screws, they cannot be used for other purposes. Distinguish these from others.
- b) Drive alignment pins [19-2] into suction cover [5-1].
- c) The bearing head [11-2] and suction cover are stuck together by gasket [17-2]. Screw in screws [18-2] (which have been removed) into the holes on the bearing head, to separate the suction cover evenly by pushing.  
Do not drive a screwdriver or chisel into the gap.
- d) The power transmission gear couplings [151 to 161] are attached to the inside of M rotor shaft. Move the main body in parallel with the shaft to separate the drive side and the driven side in the direction of the shaft.

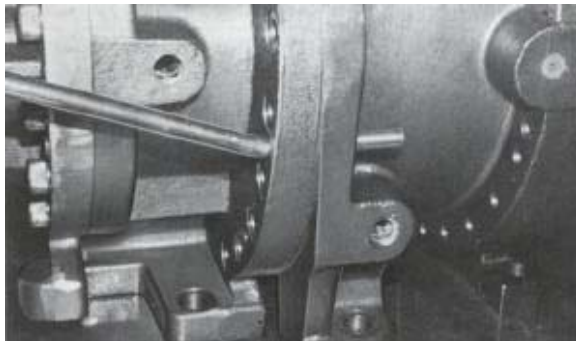

Photo 033 Separating High-stage and Low-stage



Photo 034 Low-stage After Separation

## 5.4.7 Gear Coupling

The gear coupling, which is used as a power transmission means, is divided into the high-stage and the low-stage blocks, with each block attached to the corresponding M rotor shaft, and these two blocks are directly connected by a drive sleeve.

### Gear coupling mechanism of 2016\*\*C models

In March 1982, the coupling method was changed from the initial type (coupling hub is directly connected using hexagon head screws) to the method using coupling hub and sleeve. This method was used for a long time.

However, the anti-falling method of the drive sleeve was modified in October 2010 as the design modification. While the old couplings have stoppers on both outer ends of the drive sleeve, the stoppers are placed on the inside of the drive sleeve after the design modification (compatible with the old type).

After this design modification, the drive sleeve stopper [154] and snap ring [155] are no more used.

\* Date on which design was changed: The new method was applied first to assembly in Oct. 19. 2010.  
"Model: N2016SSC-LBM Serial number: 2023130".

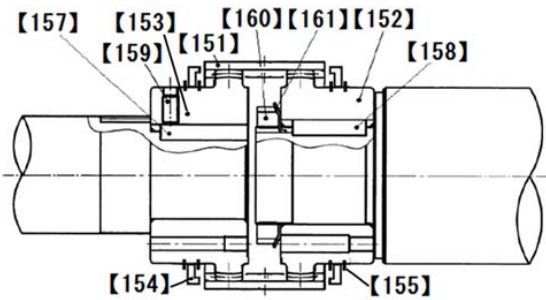

Gear coupling assembly comprising 151, 152, 153, 154\*2, 155\*2 and 159.

**Figure 5-5 Former Method**  
(Used Until Design Change in Oct. 2010)

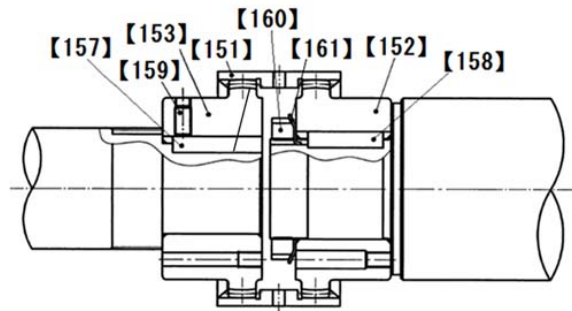

Gear coupling assembly comprising 151, 152, 153 and 159.

**Figure 5-6 New Method**  
(Used After Design Change in Oct. 2010)

#### 5.4.7.1 Disassembly

- Drive sleeve [151] can be removed with hands when the high-stage and low-stage are separated.
- On the high-stage (driven) side, loosen the set screw [159] of the key [157] attached on the driven hub [153], and then remove the driven hub. As it is clearance-fitted, it can be removed easily.
- On the low-stage side, unbend the lock washer tooth [161] and loosen the lock nut [160] to remove the drive hub [152].
- Two screw holes are provided on the drive hub. Screw in M8 eye bolts, and pull out the drive hub. As it is clearance-fitted, it can be removed easily.

#### **[POINT]**

For the set screw [159], MAYEKAWA recommends a knurled cup point locking screw with an anti-loosening coating on the screw.



Photo 035 Removing the Driven Hub



Photo 036 Current Parts of Gear Coupling

#### 5.4.7.2 Inspection

Check the hub and sleeve for possible deformation of the gear teeth and wear on each tooth flank. If any defect is found, replace the whole gear coupling assembly. Also, investigate cause(s) of the defect.

## 5.4.8 Balance Piston Cover

Disassemble this part when pulling out the rotor or when inspecting the side bearing [28-2] or balance piston.

The balance piston cover [22] is removed, combined together with the unloader cylinder [60-2]. If the unloader cylinder is pulled out and disassembled further, follow the procedure below.

- a) Loosen all of the hexagon socket head cap screws [24] by turning them three or four times, and tap the side face of the cover with a soft hammer, to release the balance piston cover gasket [23] that is stuck.
- b) In this state, drain the oil from the balance piston and side bearing block inside the suction cover. When the oil has been drained, remove all the screws except for the one on the upper side. While holding down the balance piston cover, remove the remaining screw and remove the balance piston cover.

## 5.4.9 Balance Piston

When the screw compressor is operated, the thrust load applied to the M rotor is large and the M rotor rotates very fast compared with the F rotor. Therefore, the life of thrust bearing on the M rotor would normally be much shorter than that of those attached on the F rotor.

To reduce the thrust bearing load on the M rotor, a hydraulic piston is installed at the end of the high-stage M rotor shaft in order to cancel the thrust load.

\* Note that balance piston is not used on the low-stage, because the low pressure conditions is lower than high-stage, the service life difference of the bearings is not so significant compared to the high-stage.



Photo 037 Balance Piston and Snap ring

### 5.4.9.1 Disassembly

- a) By using external snap ring pliers, remove the snap ring [32] which retains the balance piston [30] on the shaft. Screw in two M8 eye bolts, and pull out the balance piston. It is not necessary to remove the balance piston key [31] fitted in the rotor shaft.

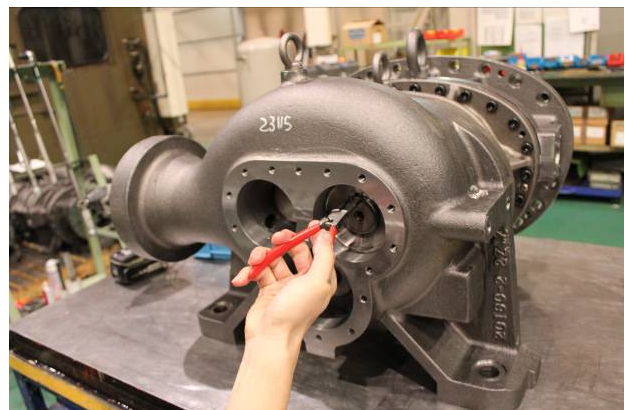

Photo 038 Removing Snap ring



Photo 039 Pulling Out Balance Piston

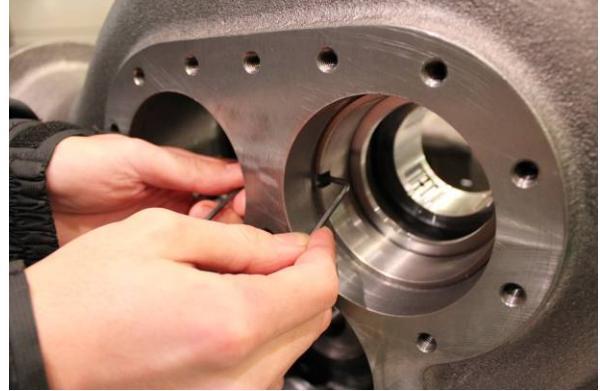

Photo 040 Loosening Set Screws Used for Stopping Rotation of Balance Piston Sleeve

- b) Then, retract the hexagon socket head cap set screws [34] which are used for locking rotation of the balance piston sleeve [33].  
Two set screws are used. Loosen the F rotor-side set screw, and get the balance piston-side set screw under the suction cover.
- c) By using internal snap ring pliers, remove the snap ring [37] which retains the balance piston sleeve. As the snap ring is pushed out by the force of the inner O-ring [35], it can be removed easily by pushing in lightly.
- d) Pull out the balance piston sleeve. As the outer diameter of the sleeve is clearance-fitted with the suction cover, it can be pulled out easily.  
Remove the balance piston sleeve, O-ring and O-ring spacer [36].
- e) The snap ring [29] attached inside the O-ring spacer need not be removed, except when removing the side bearing [28].

### 5.4.9.2 Inspection

Although there are signs of wear on the inner surface of the balance piston sleeve, this is not a problem. They result from the fact that the gap between the balance piston and the piston sleeve is smaller than the gap between the rotor shaft and the bearings.

These wears will not develop further, because a large gap is created around the outer circumference of the balance piston sleeve in order to prevent the bearing load from being applied to the balance piston. However, you should still carefully check the condition because when the side bearing is significantly worn, the balance piston may also be worn.

## 5.4.10 High-stage Suction Cover and Side Bearings

If the work sequence is such that the thrust bearing block is disassembled first and then the suction cover is removed, there is a risk that, when the suction cover is separated from the main rotor casing, the rotor may also be pulled out and dropped. As such, in the procedure described in this manual, the suction cover is removed first, and then the thrust bearing is disassembled.

### CAUTION

- **In this procedure to remove the suction cover before disassembling the thrust bearing block, it is necessary to sufficiently loosen the lock nut that are securing the thrust bearing while the rotor is supported by both the main and side bearings, in order not to damage the rotor during the disassembly process.**

### 5.4.10.1 Disassembly

- Remove the hexagon head bolts [45-2] and the conical spring washers [46-2] that are used to fasten the thrust bearing gland [43-2], and then remove the gland.  
In case of a former model which uses a rotation stopper fitting instead of a conical spring washer, extend the claw bent plate of the rotation stopper and remove it from the hexagon head bolt [46-2], and then remove the hexagon head bolt and the thrust bearing gland.
- Unbend the rotation stopper tooth of the lock washer [40-2] holding the lock nut [39-2] which retains the inner race of thrust bearing [38-2] on the rotor shaft and loosen the lock nut using a lock nut wrench.
- As the height of the high-stage main rotor casing is low, the casing is installed like a bridge to connect between the suction cover and the bearing head. As such, the main rotor casing will be supported only by one side (i.e., overhang) when the suction cover is removed. To avoid this, either place squared timbers or use a lifting device to properly support the main rotor casing.
- Loosen and remove the hexagon socket head cap screws [2-2] that fasten the high-stage suction cover [5-2] and high-stage main rotor casing [1-2].
- The suction cover gasket [6-2] is stuck to the flange surface. Screw two hexagon socket head cap screws [2-2] (which have been removed) into the threaded holes on the main rotor casing flange, to push the suction cover evenly.  
When a small gap is created, peel up one side of the gasket by using a scraper (Do not drive a screwdriver or chisel into the gap).
- At the position where the alignment pins can be disengaged, pull out the suction cover all at once in parallel with the rotor axis.



Photo 041 Pulling Out Suction Cover

- The side bearing [28-2] is press fit from the balance piston cover side of the suction cover. Release the snap ring [29-2], and push it out from the rotor side.

### 5.4.10.2 Inspection

- a) Check the oil inlet path to the balance piston part of the suction cover by spraying air or the like.
- b) We recommend unconditional exchange of the side bearings on the occasion of the compressor overhaul, but for confirmation of the compressor condition and system operating condition, carefully check the sliding part metal surface of the side bearings.  
If the metal surface is turned gray or any foreign matter is embedded, also carefully check the wear of the rotor shaft.
- c) The inside surface of the main rotor casing should have no problems because sufficient clearance is provided. However, if any trace of scraping by the end of the rotor is found, it should be determined that the thrust bearing is defective. It is also necessary to check the operational condition, such as whether the system is operated for a long time with a high intermediate pressure.
- d) The high-stage suction cover of 2016\*\*C has a hole for the unloader push rod to pass through,. Check the O-ring [9] in there, and replace it.

## 5.4.11 Low-stage Suction Cover and Side Bearings

Similarly to the case of the high-stage, the lock nut fastening the thrust bearing should be loosened before removing the suction cover.

### 5.4.11.1 Disassembly

- a) Remove the hexagon head bolts [45-1] fastening the thrust bearing gland [43-1]. As conical spring washers [46-1] are used together, be careful not to lose them.
- b) Unbend the tooth of the lock washer [40-1] to preventing the lock nut rotation, and loosen the lock nut [39-1].
- c) The oil injection pipe [85] that supplies lubricating oil for injection to the unloader slide valve is located at the lower area of the low-stage suction cover. Since the oil injection pipe is retained by the oil injection pipe gland [164], unscrew four hexagon socket head cap screws [166] and remove the oil injection pipe gland.



Photo 042 Removal of Oil Injection Pipe Retainer

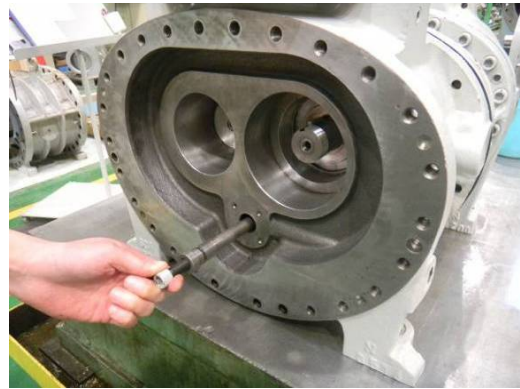

Photo 043 Pulling Out Oil Injection Pipe

- d) There are M16 threaded hole on the head of the oil injection pipe. Screw the bolts [2-1] which has been removed, and pull out the pipe.
- e) Remove all the hexagon socket head cap screws [2-1]. Then, drive alignment pins [3-1] into the main rotor casing [1-1].
- f) Screw hexagon socket head cap screws [2-1] into the two screw holes on the main rotor casing flange, to push the suction cover flange evenly.
- g) When some gap is observed between them, use a scraper to remove one side of the gasket [6-1] from the body.
- h) When a gap gets spread to a full length of the jacking screws, release the engagement of the rotor shaft and side bearing by sliding on the work bench parallel with the rotor axis.
- i) Remove the snap ring [29-1] and push out the side bearing [28-1] from the main rotor casing side.



Photo 044 Removing the Snap ring

### 5.4.11.2 Inspection

Inspect the suction cover and side bearings in the same way as for the high-stage.

## 5.4.12 Thrust Bearings Block

Thrust bearing is a face-to-face angular contact ball bearing. This bearing only receives thrust load and does not receive the radial load perpendicular to the shaft because there is a gap between the outer ring of the thrust bearing and the bearing head. Apart from receiving the thrust load, the bearing has the important role of securing the position of the gap between the rotor and the discharge side of the bearing head. This gap (end clearance) is significantly linked with performance.



Photo 045 Thrust Bearing

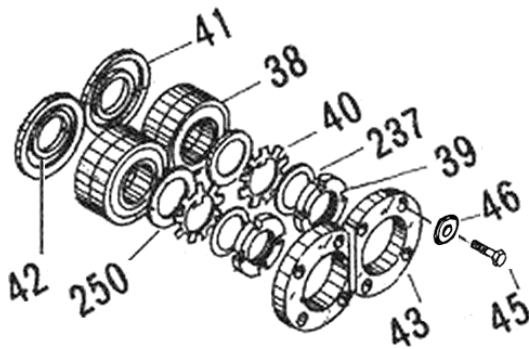

P/N	Part name	Qty.
38-2	Thrust bearing (2)	2
39-2	Lock nut (2)	2
40-2	Lock washer (2)	2
41-2	Thrust bearing outer race spacer (2)	2
42-2	Thrust bearing alignment spacer (2)	2
43-2	Thrust bearing gland (2)	2
45-2	Hexagon head bolt, M10×30	8
46-2	Conical spring washer for M10	8
237-2	Torsional slip washer for 160***	2
250-2	Thrust washer 160***	2

Figure 5-7 Thrust Bearing Block (High-stage / Low-stage)

### 5.4.12.1 Disassembly of High-stage Thrust Bearing Block

- Remove the lock nut [39-2] that has been loosened. Then, remove the torsional slip washer [237-2], lock washer [40-2], and thrust washer [250-2].
- The clearance fit is applied to two gaps between the outer race of the thrust bearing and the bearing head, between the inner race of the thrust bearing and the rotor shaft

Prepare a 1 or 2 mm diameter aluminum wire, make the tip of the wire flat by hammering, and slightly bend the tip to make a hook. Then, insert the tip of the wire between the outer race and the ball retainer of the thrust bearing [38-2] to hook and pull out the bearing. In this way, the bearing can be easily removed.

- The whole thrust bearing will be removed helped by the surface tension of the oil on the side face. If you have failed to remove the whole bearing at once, put the components in the order of the removal.
- Attached to the inside of the thrust bearing are; thrust bearing outer race spacer [41-2] for the bearing head-side outer ring, and the thrust bearing alignment spacer [42-2] for the rotor shaft side inner race. To identify where to set, the thrust bearing outer race spacers and thrust bearing alignment spacers have a stamped mark of "M" or "F" which means "for M rotor" or "for F rotor".

The bearing glands, thrust washers, thrust bearings, thrust bearing outer race spacers and thrust bearing alignment spacers, which have been removed, should be divided into two groups (M rotor group and F rotor group).

You must be very careful because if an assembly error is made to result in a wrong combination of parts after failing to neatly arranging and separating the parts, it can lead to performance degradation and/or dragging accident due to overheating caused by being too narrow end clearance, for example.





Photo 046 Pulling Out Thrust Bearing

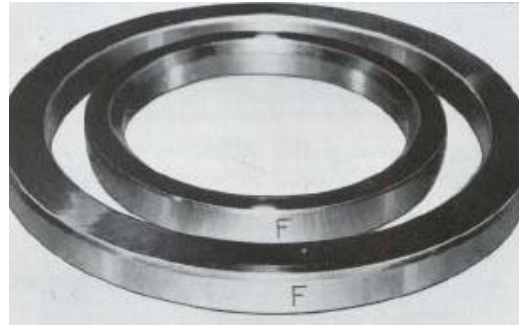

Photo 047 Stamp Marks on Outer race Spacer and Alignment Spacer

#### 5.4.12.2 Disassembly of Low-stage Thrust Bearing Block

- a) Remove the lock nut [39-1] that has been loosened. Then, remove the torsional slip washer [237-1], lock washer [40-1], and thrust washer [250-1].
- b) Similarly to the case of the high-stage, remove the thrust bearing [38-1], thrust bearing outer race spacer [41-1], and the thrust bearing alignment spacer [42-1].

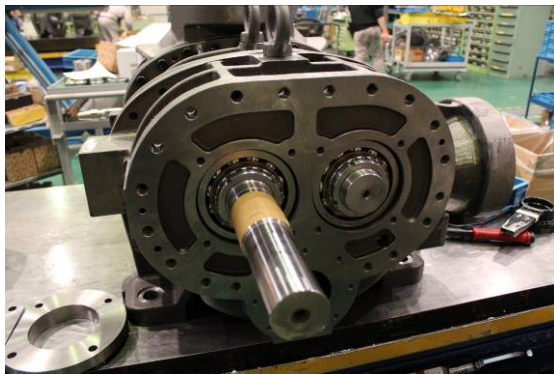

Photo 048 Thrust Bearing Glands are Just Removed



Photo 049 Bearings are Just Removed

#### 5.4.12.3 Inspection (High-stage and Low-stage)

- a) The thrust bearing is normal if the bearing balls are found fully glossy after the thrust bearing has been fully washed and cleaned. It is abnormal if the ball surface has tarnish streaky pattern.
- b) Support the inner race with your hand and rotate the outer race. If you feel abnormal vibration on the hand, the rolling contact surface of the inner or outer race or some balls may be in an abnormal condition. So, carefully check the conditions. You could feel some irregular click even with a small foreign matter that has entered during the removal process. In such a case, it should return to the normal condition when high pressure air is used to blow out the foreign matters after washing and cleaning the unit. If the bearing is determined to be defective, it must be replaced with new ones.
- c) If the inner race and outer race can be easily separated, the wear is considered excessive. If so, you cannot reuse the bearing.
- d) After washing the bearing, you should be able to hear a clattering sound when the bearing is rotated by hand. Such a sound is due to the motion of the ball within the backlash or play, or the gap between the retainer and the ball. Such a sound will not be heard if the bearing is held horizontal and turned. If some lubricating oil is applied after washing the bearing, the sound should not be heard when the bearing is turned. If you can still hear the sound, the bearing is abnormal.

- e) If any abnormality is seen in the thrust bearing in the above inspection, replace with new ones. In addition, carefully check the reason whether due to mere aging or any problem with the operating condition and/or lubricating mechanism.
- f) If the compressor has been operated for more than 20,000 hours without replacing the thrust bearing, it is recommended to replace the bearing with a new one for safely continuing the operation until the next overhaul, even if no abnormality is found in the above described inspection.

**CAUTION**

- Since a bearing is a combination of specifically designed parts, even if a bearing with the same number is found in a bearing manufacturer's catalog, the accuracy or material may not be identical. Replace the parts with **MYCOM** genuine parts. Parts other than genuine parts are not covered by the warranty.

## 5.4.13 High-stage Rotors and Main Rotor Casing

### 5.4.13.1 Disassembly

- a) Either the M rotor or F rotor may be removed first. However, as the M rotor is longer, it is easier to remove the M rotor first. When pulling out the M rotor (or F rotor) first, pull out about 2/3 of the full length of the rotor by holding the shaft upward and turning it in the CW (or CCW) direction. When approximately two thirds of the rotor has been pulled out, draw the rest out slowly while attaching the other hand to the outer circumference of the rotor.

#### CAUTION

- You should carefully note that the rotor must be rotated in the specified direction while pulling it out. If the M (F) rotor is not turned during the pulling out process, the F (M) rotor can also be pulled out together.

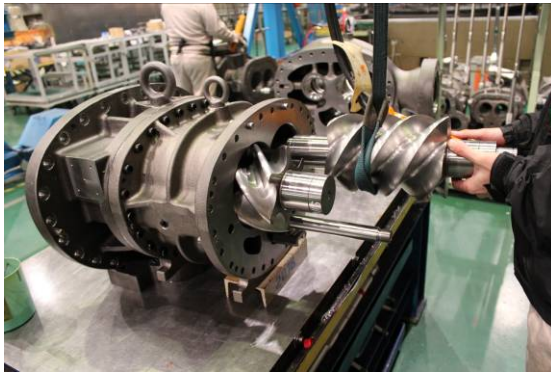

Photo 050 Pulling Out M Rotor

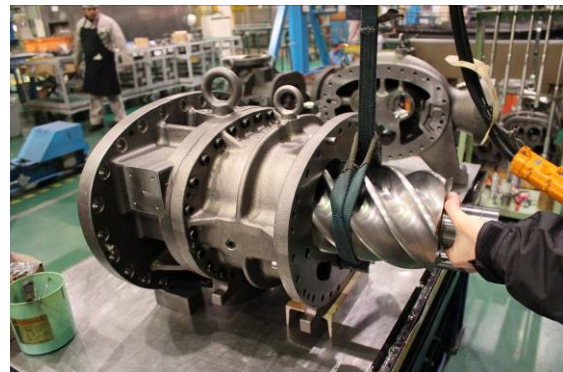

Photo 051 Pulling Out F Rotor

- b) Do not place the pulled-out rotor directly on the floor. Cover the floor with wooden pieces or the like as a cushion. Otherwise, use V-blocks to support the shaft to prevent blemishing of the outer surface.
- c) Pull out the F rotor in the same way. Take care not to get the main bearing damaged with the edge of rotor shaft during removal.

### 5.4.13.2 Inspection

- a) No abnormality should be observed on the surface of the rotor lobes under normal operations. Regarding the contact surface of the teeth, black luster should be seen on the root area of the M rotor lobes and on the tip area of the F rotor lobes. In other cases, when the suction gas or oil is contaminated by fine dust, there may be fine linear scratches on the shaft surface, in the direction perpendicular to the shaft axis. If any such flaw is found, use a fine sand paper or grindstone to smooth the surface.
- b) In case of ammonia refrigerant or gas compressor, the non-contact surface of the rotor may be discolored by rust or deposits. Use sand papers or others to finish the surface according to the degree of the problem.
- c) Then, check the bearing areas of the rotor shaft. Two types of finishing are used: one is the induction hardening (polish finishing) for the standard specification, and the other is the hard chrome plating (polish finishing), as a special specification. The most suitable finish is selected according to the type of refrigerant and operation conditions. Very little wear will be present unless the compressor is operated for a long time using dirty oil or any hard matter is buried in the metal of the inner circumference of the bearing.

- d) Check the portion of the shaft on which the thrust bearing is mounted for any trace to show that the inner race of the bearing has rotated.  
If the lock nut that fastens the inner race of the thrust bearing is loosened, or if the bearing is abnormally worn, the inner race will become rotate. If any trace of rotation is seen, correct the problem. Depending on the degree of the rotation trace, it might be necessary to replace the rotors with new ones.
- e) Check the inner surface of the main rotor casing.  
There is a narrow clearance between the periphery of the rotor and the main rotor casing. Any slight flaw present on the tip of the rotor teeth or on the inner surface of the main rotor casing, due to small foreign matters, will not be a problem.  
If there is any trace to show that the tips of the rotor teeth have hit the inner surface of the main rotor casing, it is an abnormal condition. In such a case, the possible cause is that the main bearing and/or side bearing is worn out. Take proper actions by finding the cause of the problem, such as contamination of the lubricating oil or entrance of foreign matters.

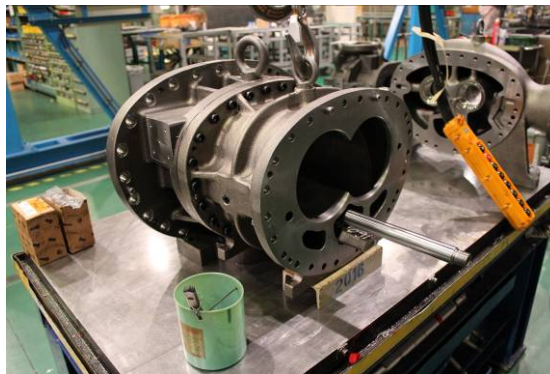

Photo 052 High-stage Rotor Casing

#### 5.4.14 Low-stage Rotors and Main Rotor Casing

Take care because the low-stage rotors are heavy.

Perform the work similarly to the case of the high-stage unit. The work should be very carefully performed as the low-stage rotors are heavier than the high-stage rotors.

Also perform the inspection work similarly to the case of the high-stage unit.

Since the low-stage M rotor is installed with a mechanical seal, do the work very carefully not to damage the shaft. It is recommended to apply a protective tape on the shaft surface.



Photo 053 Low-stage Rotor Casing

## 5.4.15 High-stage Bearing Head and Main Bearings

On the rotor mounting side of the bearing head [11-2], there is a gas discharge port as determined by the operating conditions of the compressor. This discharge port affects the performance of the compressor.

In addition, the bearing head has the main bearing that supports one end of the rotor.

### 5.4.15.1 Disassembly

- a) Place a support like a squared timber or the like under the rotor casing.  
Remove all the hexagon socket head cap screws [2-2] that fasten the main rotor casing and bearing head. Drive alignment pins [3-2] into the rotor casing.
- b) Screw two hexagon head cap screws [2-2] into the jacking threaded holes of the main rotor casing flange to push the bearing head evenly.
- c) When some gap is observe, use a scraper to remove one side of the gasket [12-2] from the body.
- d) The main bearing [27-2] is lightly press fit to the bearing head.  
To take out the main bearing, remove the snap ring [29-2] and tap the rotor side by using internal snap ring pliers.  
Then, either use a plastic block or other suitable element to push the bearing from the main rotor casing side or use a special tool to pull out the bearing. For the details of the special tool, refer to Section 5.5.2 in this chapter.
- e) The unloader slide valve assembly is installed into the high-stage of the 2016\*\*C. Draw it toward the bearing head and out. If no specific abnormality is found, no further disassembly is required.
- f) The guide block stem [88-2] is screwed from bottom of the main rotor casing, and the guide block [87-2] is engaged from the top. To replace the O-rings [89-2], remove the guide block stem.



Photo 054 After Removal of Main Bearings

### 5.4.15.2 Inspection

- a) We recommend as well as the side bearings, unconditional exchange of the main bearings on the occasion of the compressor overhaul, but for confirmation of the compressor condition and system operating condition, carefully check the sliding part metal surface of the main bearings.  
If the metal surface is gray or any foreign matter is buried, also carefully check the wear of the rotor shaft.

- b) Check the condition of the surface of the bearing head on the rotor side, where the discharge port is. Properly mend the surface if any flaw is observed. If the entire surface has significant flaws, either the thrust bearing is defective or the end clearance adjustment is poor.
- If oil compression has been caused during the operation, carefully and thoroughly check the area of the discharge port in particular. If the continued use is in doubt at all, perform the penetrant testing (color check) to determine if it can be used or not.
- c) With the unloader slide valve mounted in position, check the step height between the slide valve and the main rotor casing surfaces. ~~Generally~~ Usually, the surface of the slide valve should be lower than the surface of the main rotor casing.
- If the top surface of the slide valve has a trace of hitting the rotor, the probable cause is that the slide valve is worn or the rotor shaft/bearing is worn. Please contact our sales offices or service centers.
- d) Check the properness of the guide pin [68-2] at the tip of the unloader push rod [67-2] that engages with the indicator cam [77-2].

### 5.4.16 Low-stage Bearing Head and Main Bearings

Perform the disassembly and inspection work for the low-stage bearing head and main bearings in the same way as with the high-stage.

## 5.5 Reassembly

### CAUTION

- During the reassembly work, be very careful in selecting the correct replacement O-rings of the specified standard, not to make a mistake regarding the size, material, for fixed use, for sliding use, etc. Using a wrong O-ring can lead to oil leak or other problems.
- Some gaskets are not symmetrically shaped. In such a case, be careful not to misplace the gasket. If the gasket is misplaced, it can lead to a significant problem such as blocking any oil supply route on the casing.

After completing the disassembly and inspection procedures, start the assembly process. First, read again Section 5.1 "Precautions for Maintenance and Inspection" in this Chapter 5.

Before starting the assembly, check the replacement parts once again.

Like gaskets, all O-rings that have been removed during the compressor disassembly must be replaced with new ones.

The reassembly sequence is mostly the reverse of the disassembly sequence. First of all, clean the work bench and the tools to be used.

Immediately prior to the assembly, use washing agent (e.g., kerosene, parts cleaner) ~~oil~~ to clean the parts to be assembled, dry them with compressed air, and sufficiently apply lubricating oil, etc. For this, prepare a sufficient amount of clean lubricating oil for the reassembly. Also, apply oil on both sides of the gasket.

Because the assembly procedure is mostly similar between the high-stage and low-stage sides, the following sections provide explanations that are commonly used for both stages. For this purpose, the part number given in the common explanations will omit the distinction between high-stage and low-stage by means of a hyphenated suffix (the suffix of [\*\*-1] for low-stage and [\*\*-2] for high-stage part number will be omitted).

Please fully understand the details in this Section 5.5 for correct assembly work.

**Table 5-7 Standard Tightening Torque for Hexagon Socket Head Cap Screws**

Torque Unit	M6	M8	M10	M12	M14	M16	M20	M24
N·m	10	25	50	90	140	240	450	750
kgf·cm	100	250	500	900	1400	2400	4500	7500

When fastening the hexagon socket head cap screws, use the tightening torque specified in the above table.

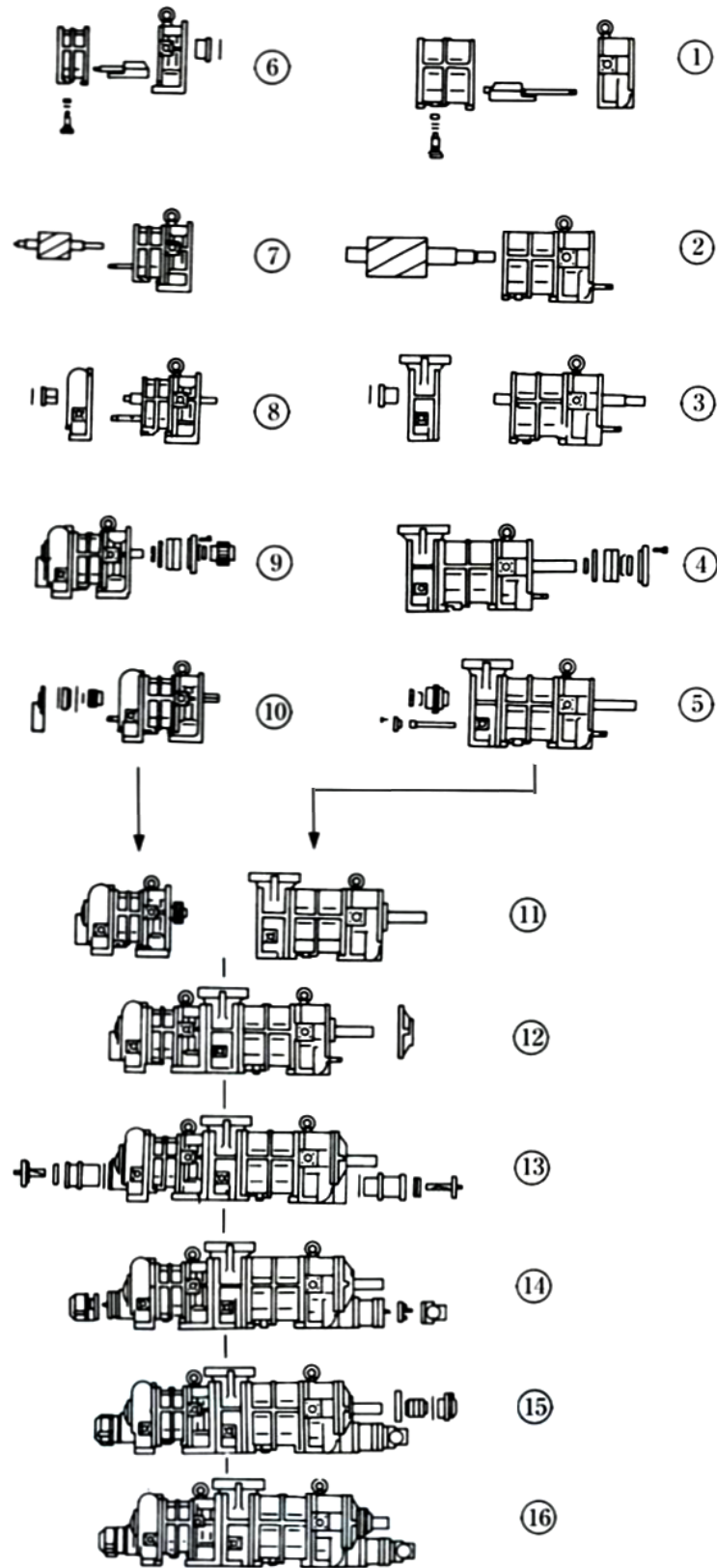

**Figure 5-8 Illustrated Assembly Sequence (example)**

\* The circled numbers in the figure do not correspond to the paragraph numbers used in the steps below.



## 5.5.1 Unloader Slide Valve and Guide Block

- a) First, tightly screw the guide block stem [88] into the bottom of the main rotor casing, and then mount the guide block [87] inside the main rotor casing.
- b) If the slide valve assembly has been disassembled, first make sure that the alignment position between the slide valves [54] and [55] is accurately reproduced and then tighten the hexagon socket head cap screws [58] with spring washers [267] at the specified torque. The outer diameter of the spring washers used here is less than normal spring washers for hexagon socket head cap screws. So, be careful not to mix up with other washers.
- c) After using a grind stone or fine sand paper to lightly finish the circumference of the unloader slide valve assembly, mount the assembly in the main rotor casing. Then, slowly push-in the push rod while aligning the groove of the slide valve with the guide block.
- d) After it is assembled, hold the unloader push rod and move it for several times to check that it moves smoothly. Then, carefully check the joint with the main rotor casing that there is no step between them.

If there is a step, check it by reversing the orientation of the guide block first. If the step is still present, it should be due to imperfect assembling, and it must be reassembled.

\* Regarding the unevenness between the unloader slide valve and the main rotor casing, there is no problem if the slide valve is slightly lower than the casing.

### CAUTION

- **If the unloader slide valve is higher than the main rotor casing, there is a problem in assembly. Do not leave the problem as it is. Be sure to reassemble. If used without correcting it, the outer periphery of the rotor may hit against the slide valve, which will cause a severe damage accident.**

- e) The low-stage slide valve assembly has an oil injection pipe guide [168] on the opposite side of the push rod. Do not forget to install the O-ring [59] (Photo 056).



Photo 055 Guide Block Stem Inside Casing



Photo 056 O-ring for Oil Injection Pipe Guide

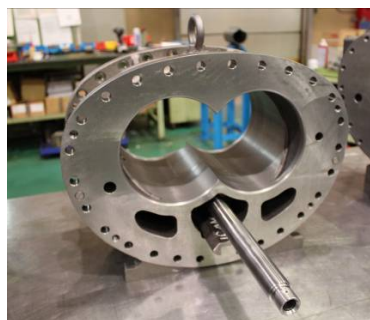

Photo 057 High-stage Rotor Casing

## 5.5.2 Bearing Head and Main Bearings



Photo 058 Attaching Main Bearing  
(High-stage)

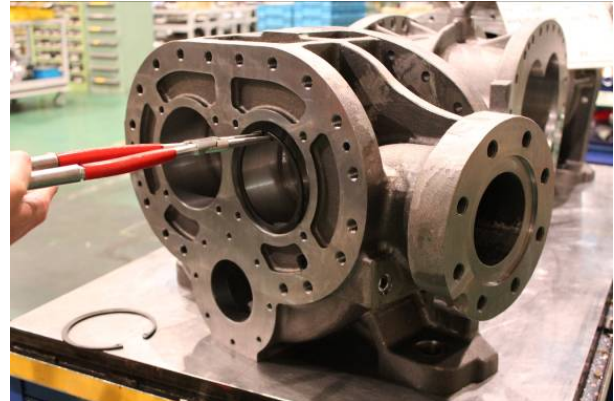

Photo 059 Securing with Snap ring  
(Low-stage)

The main bearing (O-ring type) [27] is installed by a light press fit.

- a) Align the notch on the main bearing with the spring pin [14] that is driven in into the bearing head [11], and then push it in with a pad. For the alignment, it is convenient to use a tool such as a guide bar (Photo 058).
- b) After the bearing has been inserted, install the snap ring [29] to retain the bearing in position (Photo 059). Securely install the snap ring to be fully seated in the ring groove, by pushing the snap ring with a guide bar or the like, or by lightly hitting the guide bar with a hammer while placing the guide bar on the snap ring.

### 【POINT】

When press fitting, using a weight jig and a plastic spacer indicated in the Figure 5-9 makes attaching bearing works easier. The plastic spacer should be just the right size of the bearing inner diameter and hit the spacer inside with the weight jig.

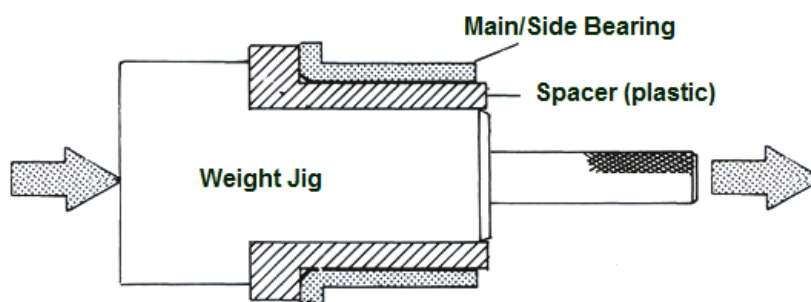

Figure 5-9 Spacer and Weight Jig (example) for press fitting a Bearing

### 5.5.3 Bearing Head and Main Rotor Casing

#### CAUTION

- Since the bearing head gasket [12] is not formed symmetric laterally, pay attention to the installation direction.
- If you place the bearing head gasket by just hanging it on the stud bolts, the gasket will protrude into the inside of the rotor casing when the casing is assembled. Apply sufficient amount of oil, etc. to the gasket to make it fully attached to the surface to prevent protruding upon the assembly.

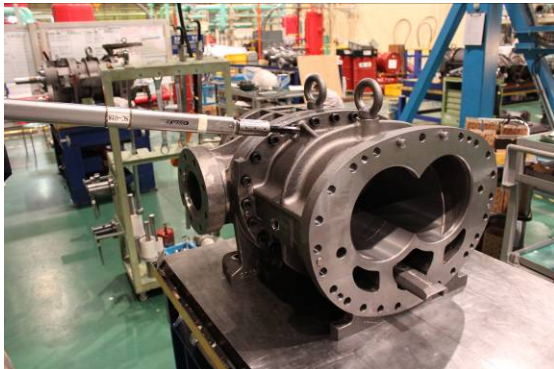

Photo 060 Fastening Low-stage Assembly with Bolts



Photo 061 High-stage Assembly

- a) In case of assembling the low-stage, fit the unloader push rod [67-1] in the hole of bearing head [11-1]. Then, slide the bearing head or main rotor casing to let them mate together.
- b) Loosely tighten two bolts in symmetrical positions. Next, drive in the alignment pins [3-1] to fix the position, and then screw bolts in opposing positions, and then fasten the bolts evenly in turn.
- c) After fastening the bolts, check that the bearing head gasket is not protruding toward the inside of the casing.
- d) Also, move the slide valve back and forth to check that it works normally.

#### CAUTION

- Make sure to check for protrusion of the bearing head gasket after assembling the bearing head and rotor casing. If this work is not performed, measurements may be incorrect due to the gasket becoming stuck between the end of the rotor and the surface of the bearing head when adjusting end clearance. Also, performance may deteriorate by operating the compressor after confirming the incorrect end clearance.

- e) Since the full height of the high-stage main rotor casing is lower than that of the bearing head, both centers will not be aligned when they are placed on the work bench. Therefore, either use a pedestal as used in the disassembly process or lift the rotor casing using a crane or other device to align the centers.  
The assembly procedure after mating the both casing flanges is same as the high-stage.
- f) The bottom bolts that cannot be fastened on the work bench should be fastened during final assembly, **placed on the special stand** which was used during disassembly.

## 5.5.4 Installing Rotors

### Note on the rotor profile of 2016\*\*C

The rotor profile has been changed from the A profile to O profile from the production in November 1993.

The most significant difference is the existence of the edge on the lobe tip. Edged A-profile has been changed to the edgeless O-profile.

Make the rotor sufficiently adjusted. By using fine sandpaper, remove over any damage on the shaft surface of the bearing and seal.

Both the M and F rotors have certain engagement positions which are indicated by engravings.

To facilitate the alignment when attaching to the main rotor casing, numbers are engraved on the discharge-side lobe peak of the M rotor and the suction-side lobe peak of the F rotor, respectively.



Photo 062 M Rotor Mating Mark



Photo 063 F Rotor Mating Marks

- Sufficiently lubricate the main bearing inside the bearing head as well as the bearing portion of the rotor shaft.
- While it is easier to mate the markings if the F rotor is first installed into the casing, it is not a mistake to install the M rotor first.
- Regardless of which rotor is installed first, engage the M rotor lobe, which has engraved mark 1, between the F rotor lobes having engraved marks 1 and 2. As factors, such as mating of lobes, balance, etc., should be considered, be sure to mate the lobe profiles as instructed.

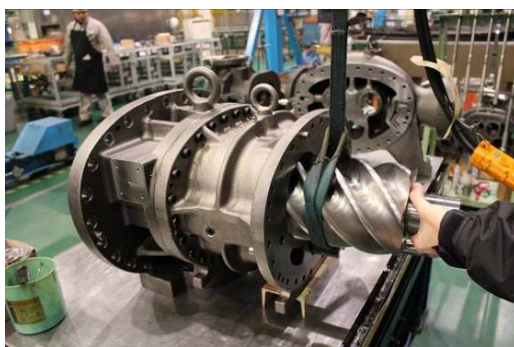

Photo 064 Attaching F Rotor



Photo 065 Attaching M Rotor

### CAUTION

- In this state, the rotor's outer periphery is in contact with the main rotor casing. Do not rotate it much. Letting it rotate may cause its tooth tips to get worn.**

### 5.5.5 Suction Cover and Side Bearings

a) The side bearing (O-ring type) [28] is dimensioned in such a way that it is lightly press fit to the suction cover [5].

Align the notch of the bearing with the positioning pin[8]which is driven into the suction cover, and press fit the bearing. During the press fit, check the position of the pin and the notch. If the position is misaligned, pull the bearing out once and then press fit it again.

When the assembly is finished, secure the side bearing by using the snap ring [29] (Photo 067, 069).



Photo 066 Attaching Side Bearing  
(Low-stage)



Photo 067 Securing with Snap ring  
(Low-stage)



Photo 068 Attaching Side Bearing  
(High-stage)

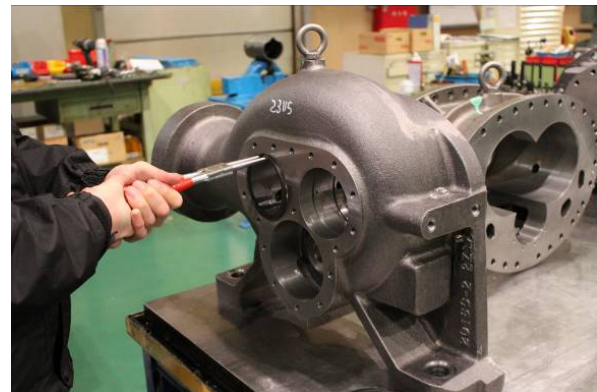

Photo 069 Securing with Snap ring  
(High-stage)

## 5.5.6 Balance Piston Sleeve

Attach the balance piston sleeve to the high-stage suction cover, by the procedure below.

- After attaching the internal snap ring [37], attach the O-ring spacer [36].
- The size of the O-ring [35] for balance piston sleeve is rather small. Extend it slightly all over with your hands before attaching it.
- Install the balance piston sleeve [33].
- Screw two set screws [34] for preventing rotation of the balance piston sleeve (Photo 073), and then attach the internal snap ring [37] to retain the balance piston sleeve (Photo 075).



Photo 070 Attaching O-ring Spacer (High-stage)

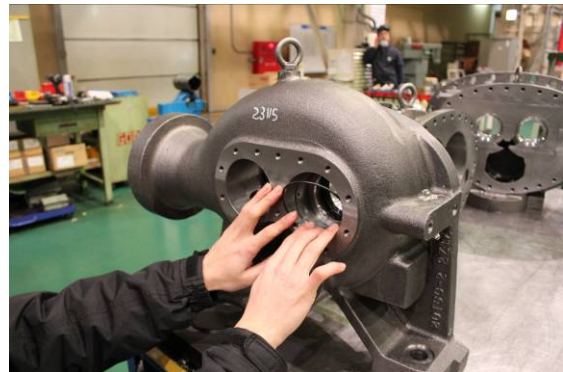

Photo 071 O-ring for Balance Piston Sleeve



Photo 072 Attaching Balance Piston Sleeve

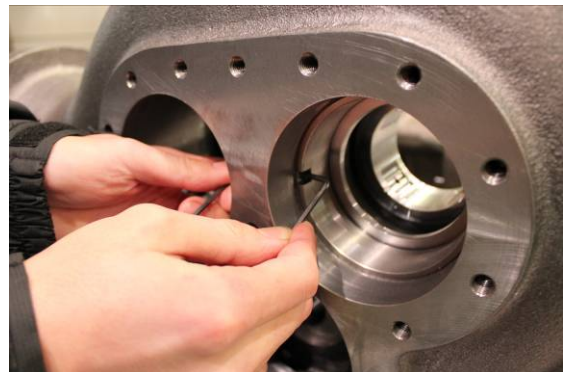

Photo 073 Screwing Set Screws for Stopping Rotation



Photo 074 Two Set Screws Have Been Screwed



Photo 075 Attaching Snap ring

## 5.5.7 Installing Suction Cover

- a) The suction cover gaskets [6-1] [6-2] are not formed symmetric laterally. Apply oil on both sides of the gasket, and attach it to the main rotor casing side while carefully checking the position of oil supply holes. Lubricate the side bearing sufficiently too.



Photo 076 Installing Low-stage Suction Cover



Photo 077 Installing High-stage Suction Cover

- b) On the high-stage, pass the unloader push rod through the hole on the lower area of the suction cover.  
Slide the suction cover on the work bench, and move it to the assembly position. When fitting the side bearing and the rotor shaft, be careful not to let the end of the rotor shaft damage the metal on the inner surface of the side bearing.
- c) When the rotor shaft fits in the side bearing, push the suction cover parallel with the shaft axis to the main rotor casing for assembly.
- d) When the suction cover is pushed until it contacts the flange surface, fasten several hexagon socket head cap screws [2] lightly, and drive two alignment pins into the suction cover for positioning.
- e) Then, fasten the bolts [2] evenly. The bottom bolts that cannot be fastened on the work bench should be fastened during final assembly, **placed on the special stand** which was used during disassembly.
- f) Rotate the M rotor shaft with your hand, and check the rotors mating condition.
- g) On the low-stage, attach the O-ring [86] to the oil injection pipe [85].  
Screw the hexagon socket head cap screw M16 into the threaded hole of the oil injection pipe as same as disassembly way, and push it into the suction cover.
- h) Then install the oil injection pipe gland [164] attached the O-ring [165], and fasten it by four hexagon socket head cap screws [166] (Photo 079).



Photo 078 Driving In Alignment Pin for Positioning



Photo 079 Oil Injection Pipe Retainer

- i) Move the push rod with your hand, and check that the unloader slide valve is working smoothly.
- j) While holding the M rotor shaft with your hand, move it in the axial direction and check that there is allowance in the axial direction.
- k) To the high-stage, attach the balance piston [30] and secure it with the external snap ring [32]. Check that the snap ring fits well in the groove.



080 Attaching the Balance Piston

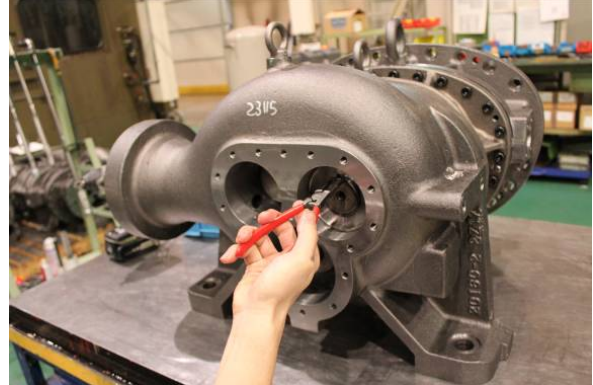

Photo 081 Attaching the Snap ring

- k) Attach the load capacity adjustment spacer (spacer for 20 % load) [420] to the high-stage push rod.



Photo 082 Attaching Load Capacity Adjustment Spacer  
(Spacer for 20 % Load)



## 5.5.8 Thrust Bearing Block

Thrust bearing is a component of the screw compressor that is playing the most important role.

This component's assembly/adjustment quality could affect the compressor performance or cause problems. Be very careful when assembling/adjusting this block.

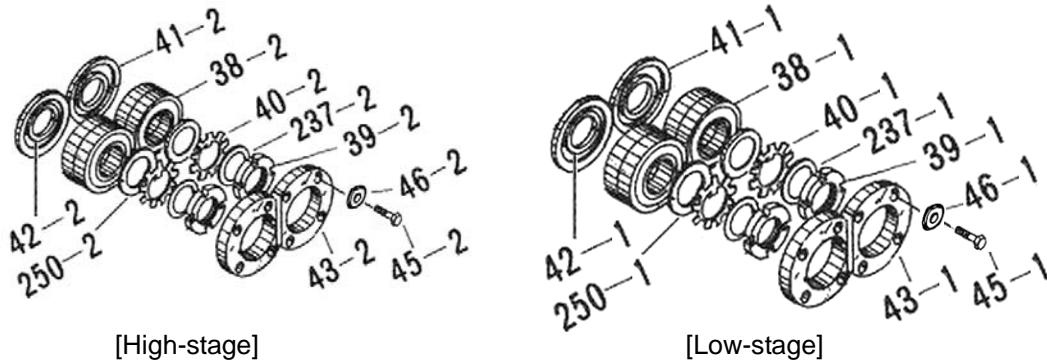

Figure 5-10 Thrust Bearing Block

Table 5-8 Parts List of Thrust Bearing Block

P/N	Part name	Qty.
42-1, 42-2	Thrust bearing alignment spacer (1), (2)	Two for each
41-1, 41-2	Thrust bearing outer race spacer (1), (2)	Two for each
38-1, 38-2	Thrust bearing (1), (2)	Two sets for each
250-1, 250-2	Thrust washer (1), (2)	Two for each
40-1, 40-2	Lock washer (1), (2)	Two for each
237-1, 237-2	Torsional slip washer (1), (2)	Two for each
39-1, 39-2	Lock nut (1), (2)	Two for each
43-1, 43-2	Thrust bearing gland (1), (2)	Two for each
46-1, 46-2	Conical spring washer (1), (2)	Eight for each
45-1, 45-2	Hexagon head bolt (1), (2)	Eight for each

### CAUTION

- When assembling the disassembled thrust bearing without replacing any parts, check the M and F engravings on the thrust bearing outer race spacer and thrust bearing alignment spacer, and reassemble them in the same way as before disassembly. This is essential to control the end clearance of the rotor discharge side.
- Even when assembling the same bearing, dimensions may become incorrect if flakes of paint or dirt are caught between spacers and alignment spacers.
- Regarding the direction of thrust bearing assembly, there may or may not be a V-shaped mark for assembly on the outer periphery of the bearing. Follow the instructions below for each case of assembling.

a) The procedure for assembling this block is described in Figure 5-10. The important points are explained below.

If there is a V-shaped mark for assembly on the outer periphery of the thrust bearing, assemble with the pointed end of the mark on the inner side of the machine, as there is a slight directional difference that affects end clearance adjustment.

If there is no V-shaped mark, assembly direction does not affect end clearance adjustment. However, to clarify the difference between the inner side and outer side of the machine, assemble the thrust bearing with the bearing number engravings on the outer side. Then, put down a V-shaped mark on the side which is to be attached to the inner side of the machine, by using blue whetstone.

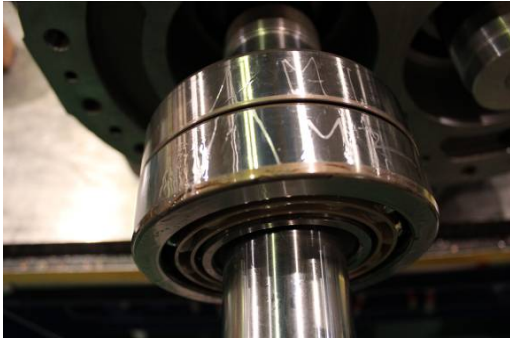

Photo 083 Thrust Bearing Assembly Mark

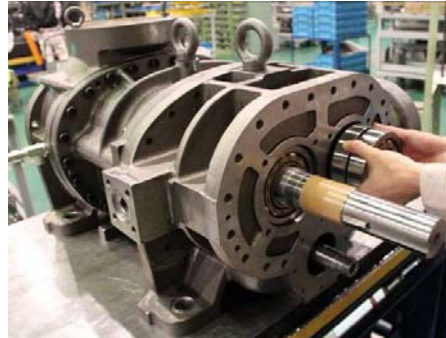

Photo 084 Attaching Thrust Bearing

- b) After installing the thrust bearing, attach the thrust washer, lock washer and torsional slip washer. Fasten the lock nut with the specified torque or tightening angle range (see Section 7.3 "Tightening Torques for Bolts and Nuts" in this manual Chapter 7), so that the inner race of the thrust bearing is fit in the rotor shaft.

**【POINT】**

Tightening the lock nut while keeping the setting position between the lock nut wrench hooks and the lock nut grooves may cause to make the rotor run-out to enlarge due to uneven tightening forces.

Change the setting position between the lock nut wrench hooks and lock nut grooves about four times when fastening the lock nut.

- d) Turn the M rotor shaft by hand, to make sure that rotation of rotors is smooth.

**CAUTION**

- Since the inner race of the thrust bearing is clearance-fitted for ease of access at the assembly site and is secured by the tightening force of the nut alone, the tightening work is very important!
- If the thrust bearing has been replaced, the difference between the bearing inner race and outer race surfaces is different even when it is within standard values. Therefore, if the thrust bearing alignment spacer hitherto used lacks required thickness, fully tightening the nut from the start may lead to a noticeable reduction in the life of bearing, due to a lack of end clearance between the rotor and the bearing head discharge end face, and also due to indentations on the contact surface formed by ball pressure. To avoid this, rotate the rotor while tightening the locknut lightly. Tighten the inner race, while checking that there is enough clearance for the outer race. If the rotor does not rotate smoothly, the thickness of the thrust bearing alignment spacer is insufficient.

### 5.5.8.1 End Clearance Measurement

At this point (i.e., after the thrust bearing block has been fully assembled), measure the clearance between the bearing head end face and the rotor end face on the discharge side. This clearance is called as the end clearance.

In particular, this measurement must be made when the thrust bearing has been replaced. Even if the same bearing is used, the measurement should be made for verification.

If the measured clearance does not satisfy the range specified in Table 5-9, proper adjustment must be made.

**Table 5-9 Specified Range of End Clearance (Unit : mm)**

Model of the compressor	High-stage	Low-stage		
		S	M	L
2016**C	0.04 to 0.05	0.26 to 0.30	0.28 to 0.32	0.31 to 0.35

■ End clearance of 2016\*\*C is the same as A-profile rotor and O-profile rotor.

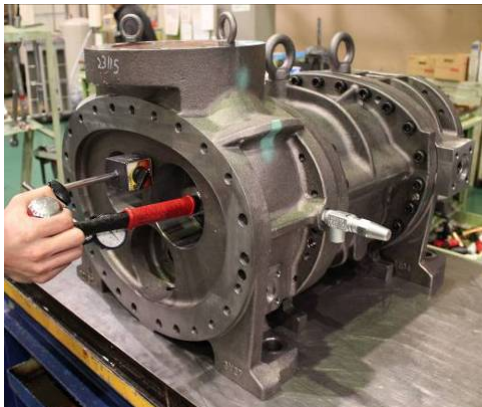
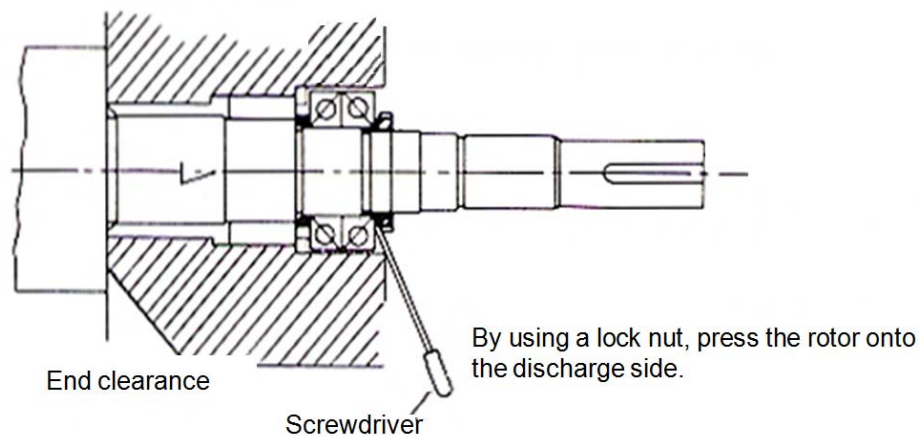

Photo 085 Pushing Rotor from Suction Side



Photo 0868 End Clearance Measurement

- a) Push the rotor to the discharge side while the thrust bearing inner race is secured to the rotor shaft. Push the rotor from the suction side to the discharge side by using a jig (Teflon). Alternatively, by using a chamfered part of the lock nut, pull out the rotor with the edge of a flat blade screwdriver as shown in Figure 5-10.
- b) When the rotor has been pushed to the discharge side, prepare to install the thrust bearing gland. Attach a dial gauge on the suction side axial end of the rotor, and match the needle to 0.



**Figure 5-11 Preparation for End Clearance Measurement**

- c) Fasten the bearing gland by tightening the four bolts (without conical spring washer inserted) evenly and gradually to the specified torque. Tightening each bolt to the specified torque at once will lead to uneven tightening. Tighten bolts in turn and in several steps.
- d) Then, read the dial gauge measurement. This value is the actual end clearance.

If the end clearance is outside the specified value, perform the adjustment work described in the next section. If the end clearance is within the specified value, turn the M rotor shaft by hand and confirm the smooth turning without uneven tightening. And then perform the measurement of the run-out of the rotor shaft described in next section (3).

**Table 5-10 Tightening Torques for Thrust Bearing Glands**

Model of the compressor		Tightening torque	
		N-m	kgf-cm
2016**C	High-stage	40	400
	Low-stage	50	500

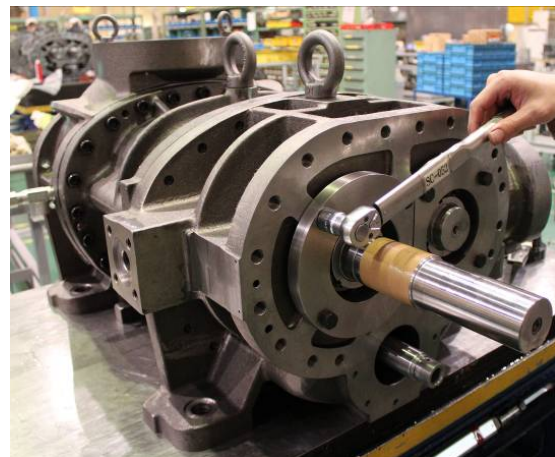
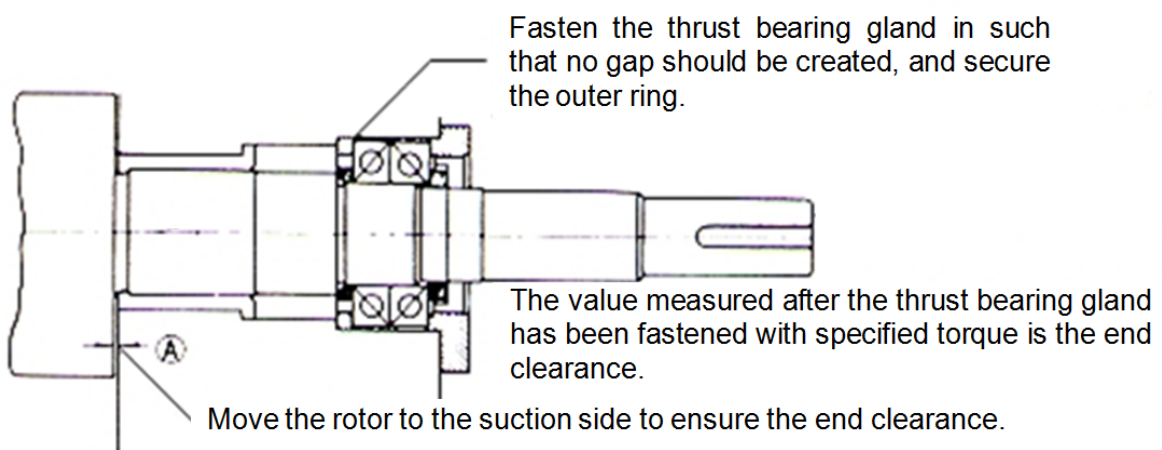

Photo 087 Fastening with Bearing Gland



**Figure 5-12 End Clearance Adjustment [ II ]**

### 5.5.8.2 Procedure for End Clearance Adjustment

- (1) When end clearance is smaller than the specified value

To deal with this, insert shim material (thrust adjustment liner) of required thickness (difference in thickness from the specified value) between the thrust bearing alignment spacer [42] and thrust bearing inner race.

\* The thrust adjustment liner is not shown in the sectional view and development view, but available from us. Place an order together with a model name.

Or using a highly accurate surface grinding machine or asking professional service vendors to grind, grind the surface of thrust bearing outer race spacer [41] by the difference from the specified value. After grinding the flat surface, measure the whole circumference of the saucer by using a micrometer, and check that the thickness is even.

(2) When end clearance is larger than the specified value

As the end clearance is excessive, remove shim material (thrust adjustment liner) of a thickness equal to the difference between the measured value and the specified value if the shim material is used between thrust bearing alignment spacer and thrust bearing inner race.

Or if the shim material is not used between thrust bearing alignment spacer and thrust bearing inner race, or even if used but insufficient thickness, grind the surface of thrust bearing alignment spacer[42] by the difference between the measured value and the specified value or ask professional vendors to do so.

After grinding the flat surface, measure the whole circumference of the spacer by using a micrometer, and check that the thickness is even.

(3) Rotor ~~axial~~ runout measurement

When the end clearance has been adjusted to within the specified range, place a dial gauge on the mechanical seal attachment part of the low-stage M rotor shaft. Measure ~~axial~~ runout by turning the rotor shaft.

The tolerance for ~~axial~~ runout is 0.03 mm or less for all models.

Runout occurs when the thrust bearing alignment spacer and saucer are not parallel or when the thrust bearing mark is not at the correct side. And it occurs if fastening the lock nut performed without changing the position of the lock nut wrench (i.e., the uneven fastening of the lock nut).

Moreover small particles of dirt trapped between parts may cause excessive runout.

If ~~axial~~ the rotor runout is over the tolerance, even if the end clearance is within the specified range, disassemble and adjust the relative positions of the spacer, alignment spacer and thrust bearing.

This is important because it affects the life of the mechanical seal and its performance.

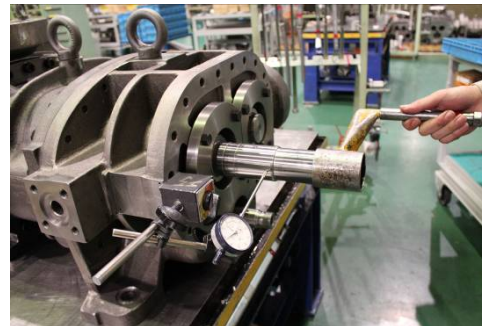

Photo 088 Measuring Runout of Shaft

### 5.5.8.3 Tightening after End Clearance Adjustment

- Bend the lock washer claw to the notch of the lock nut which is tightening the thrust bearing inner race, to prevent rotation.
- Remove the hexagon head bolts that are tightening thrust bearing gland [43] one by one. Insert conical spring washers [46] as rotation stoppers, and tighten to the specified torque again.

**[POINT]**

Conical spring washer has been adopted instead of the plate type lock washer from October, 2001.

When using the conical spring washers for the compressors produced before this modification, the hexagon head bolt heads may interfere with the low-stage bearing cover inner face.

In case of overhauling the compressor produced before October, 2011, do not change the lock washer [46] to the conical spring washer.

## 5.5.9 Bearing Cover

- a) Before installing the bearing cover [16], confirm once again that the lock washer teeth of the thrust bearing block bended as a rotating stopper and that all the hexagon head bolts for holding the thrust bearing gland have conical spring washer inserted.
- b) For ensuring the safety, screw two stud bolts in the upper bolt holes on the flange of the low-stage bearing head [11-1].
- c) Apply oil to the bearing head flange surface and the both surfaces of the bearing cover gasket (1)[17-1]. Hang the gasket on those stud bolts in such that it is put on the flange surface.

### CAUTION

- **The bearing cover gasket is not symmetric because there is a hole for lubricating oil line to the mechanical seal block in the left (seal) side. Be careful that do not mistake the direction of the gasket when attaching onto the bearing head flange surface. Mistaken the direction of the gasket causes the lubrication failure to the mechanical shaft seal block.**

- d) Attach O-ring [197] to the part where the push rod goes through bearing cover [16].
- e) Attach lifting tools to the eye bolt of the bearing cover [16]. Install the bearing cover taking care not to let it touch the M rotor shaft or push rod. After it is hung on the stud bolts, the lifting tools can be removed (Photo 090).
- f) Align the alignment pins with the hole. Tap the flanged part of the bearing cover alternately with a soft hammer to install the cover in position. When it becomes possible to screw in bolts, screw in two or three bolts. Evenly narrow the gap until the mating surfaces come in contact, and then tighten the other bolts.



Photo 089 Stud Bots and Gasket

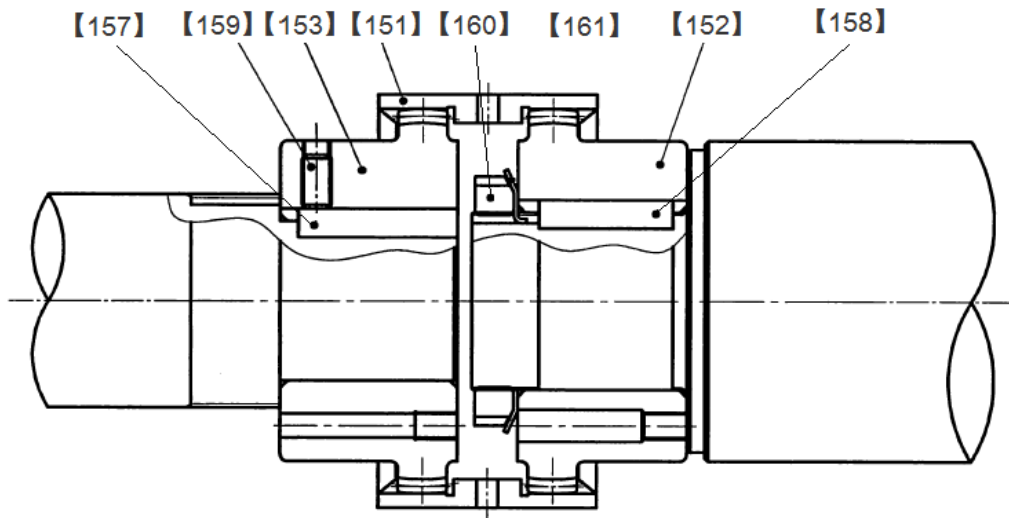

Photo 090 Installing Bearing Cover



Photo 091 Tightening Bearing Cover

### 5.5.10 Coupling High-stage and Low-stage Blocks



<b>【157】</b>	<b>Key, driven hub</b>	<b>【160】</b>	<b>Lock nut</b>
<b>【159】</b>	<b>Set screw</b>	<b>【161】</b>	<b>Lock washer</b>
<b>【153】</b>	<b>Driven hub</b>	<b>【152】</b>	<b>Drive hub</b>
<b>【151】</b>	<b>Driven sleeve</b>	<b>【158】</b>	<b>Key, Drive hub</b>

**Figure 5-13 Assembly Drawing of Gear Coupling**

- On the high-stage, attach the driven hub [153] of the gear coupling, and fasten the M8 set screw [159] for securing the driven hub key [157]. This set screw is knurled and provided with anti-loosening.
- On the low-stage, attach the drive hub [152], lock washer [161] and lock nut [160] in this order. Fasten the lock nut with the specified torque or tightening angle range (refer to Chapter 7 Section 7.3 "Tightening Torques for Bolts and Nuts" in this manual). Align the lock washer tooth with the notch of the lock nut, and bend it.
- Set the driven sleeve onto the low-stage drive hub.

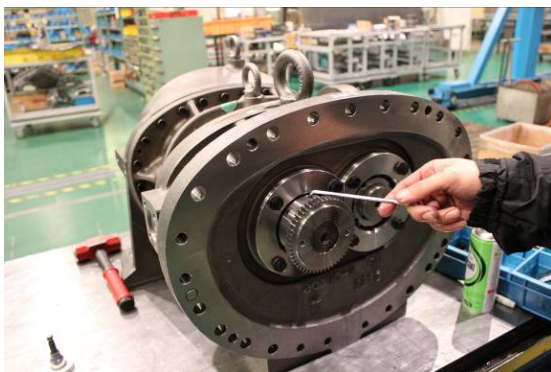

Photo 092 Tightening the Set Screw for Securing Driven Hub

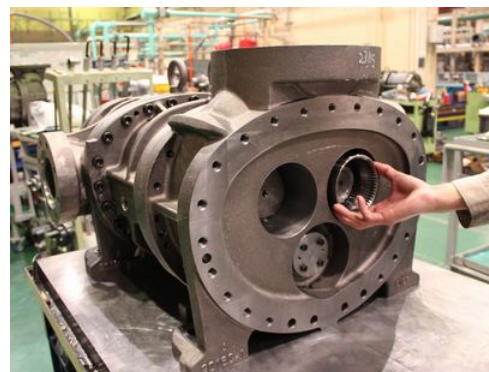

Photo 093 Setting Driven Sleeve onto Low-stage

- d) Screw stud bolts into two of the upper holes provided in the low-stage suction cover flange surface which is to be attached to the high-stage.
- e) Apply sufficient oil to the both surfaces of the bearing cover gasket (2) [17-2]. Attach the gasket on the flange surface over the stud bolts.
- f) Lift the high-stage by using lifting tools until it is slightly off the work bench, and move it toward the low-stage. At this moment, on the low-stage, slightly move the M rotor shaft in both directions, so that the gear coupling assembly will fit smoothly.
- g) After the gear coupling is engaged, press the high-stage block parallel with the rotor shaft. For both upper and lower side, gradually and evenly tighten, temporarily, the hexagon socket head cap screws [18-2] that are set in the bolt holes, each hole located one hole apart from the left or right alignment pin, until the high-stage and low-stage flange surfaces come into contact.
- h) After the flange surfaces come into contact, slightly loosen the four hexagon socket head cap screws, which have been temporarily tightened, and then drive in the left and right alignment pins.
- i) Tighten the hexagon socket head cap screws to the specified torque (240 N·m). The lower bolts should be tightened on the special stand, which was used during disassembly.
- j) Turn the low-stage M rotor (use of a jig for rotating the rotor is helpful), and check that it rotates properly.



Photo 094 Attaching the Gasket onto the Low-Stage Flange Surface



Photo 095 Attaching High-stage and Low-stage



### 5.5.11 Balance Piston Cover and High-stage Unloader Cylinder

The 2016\*\*C model has the unloader cylinder [60-2] also on the high-stage. To facilitate the assembly work, attach the unloader cylinder [60-2] to the balance piston cover [60-2] first, and then attach the united body to the high-stage suction cover [5-2].

The balance piston cover and unloader cylinder are often omitted from disassembly unless specifically needed. Accordingly, steps a) through d) below shall apply when they have been disassembled.

- a) Attach the O-ring [63] to the O-ring groove provided on the surface of the balance piston cover where the unloader cylinder is to be installed (Photo 96).

**【POINT】**

According to the design change on October 1996, the place O-ring [63] is attached has been changed from the opening with chamfered to the current position indicated in photo098. At the same time the same design modification was applied to low-stage bearing cover. Refer to the next Section 5.5.12 in this chapter.

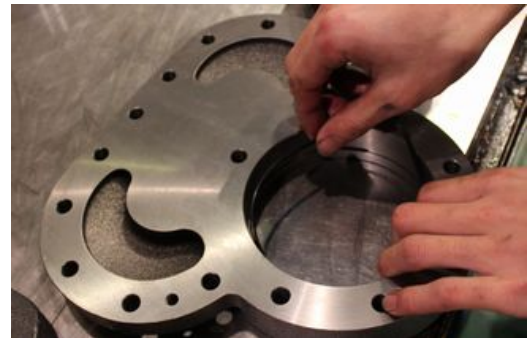

Photo 096

- b) Align the balance piston cover with the unloader cylinder. A gasket cannot be inserted between the aligning flange surfaces of the balance piston cover and unloader cylinder. So, as shown in Photo 101, thinly and evenly apply special synthetic rubber liquid gasket onto the mating flange surface of the unloader cylinder at the inner radius from the center positions of the bolt holes.
- c) As O-ring is inserted, attach the balance piston cover while tapping its flange surface with a soft hammer (as shown in Photo 98).
- d) When mating the both flange surfaces, also align the bolt holes. Fasten the two hexagon socket head cap screws [61], one at the position shown in Photo 103 and the other at the position spaced two bolt holes apart from it.



Photo 097



Photo 98

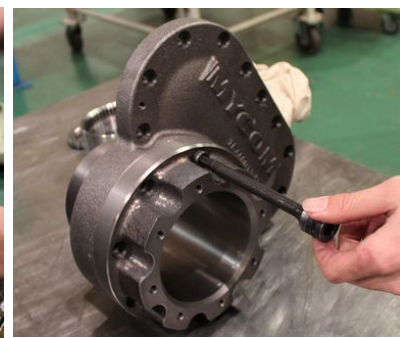

Photo 99

- e) Fit the O-ring [73-2] in the O-ring groove at the end of the unloader push rod [67-2] where the unloader piston is to be attached.

- f) Attach the O-ring [65] without lubricating oil to the unloader piston[64-2], and then attach the cap seal [66] on them. Lightly making a mountain fold in the circumferential direction of the cap seal will facilitate the work. Use of a small and smooth spatula-shaped tool (as shown in Photo 100) will aid the assembly.
- g) Attach the unloader piston, which has the O-ring and cap seal attached, to the unloader cylinder. The unloader piston has a surface which has threaded holes for eye bolts and another surface without such holes. First, while exchanging these surfaces alternately several times using the chamfer of the unloader cylinder, press the unloader piston lightly with the palm to settle the cap seal. Finally, apply lubricating oil to the unloader cylinder, then, push and install the unloader piston with its surface having threaded holes faced to the unloader cylinder cover as shown in Photo 102. After attaching, check that the cap seal is not broken or pinched.



Photo 100



Photo 101 First Fit in  
Reverse Direction



Photo 102

- h) Push the unloader piston into around the midst of the unloader cylinder. With the unloader push rod [67-2] pulled toward you, install the balance piston cover with gasket attached (as shown in Photo 102), onto the high-stage suction cover (Photo 103). If you push the piston into the push rod and temporarily tighten it with the lock nut [69-2], the work that follows will be easier.

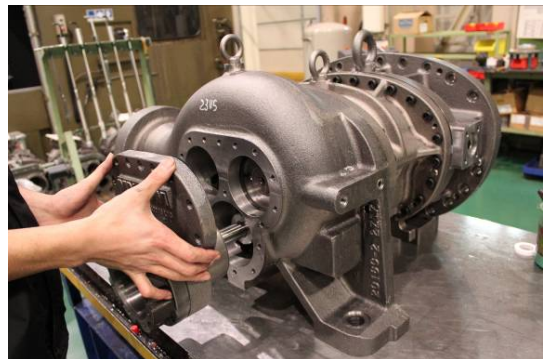

Photo 103

- i) Align the flange surfaces, and tighten the hexagon socket head cap screws to the specified torque (50 N·m).

- j) Pull the piston toward you by using eye bolts, and remove the temporarily tightened lock nut. As shown in Photo 106, attach the lock washer [70-2] and lock nut [69-2] to the push rod, and fasten the lock nut to the specified torque of 80 N·m (Photo 105). To stop rotation, bend the lock washer tooth aligned with the notch of the lock nut (Photo 106). Lastly, check the movement of the piston by using eye bolts.



Photo 104



Photo 105



Photo 106

### 5.5.12 Low-stage Unloader Cylinder

The low-stage unloader cylinder may be installed immediately after installing the bearing cover (refer to Section 5.5.9 "Bearing cover" in this manual), or after attaching the mechanical seal (refer to the description below). The contents of and points for this work are almost the same as the previous section.

- a) Attach the O-ring [73-1] in the O-ring groove at the end of the unloader push rod [67-1] where the unloader piston is to be attached.
- b) Attach the O-ring [65] and cap seal [66] to the unloader piston [64-1].
- c) Attach the unloader piston, which has the O-ring and cap seal attached, to the unloader cylinder [60-1] (Photo 109).
- d) Attach the O-ring to the O-ring groove provided on the portion of the bearing cover [16] where the unloader cylinder is to be attached (Photo 108).

\* According to the design change on October 1996, the place O-ring [63] is attached has been changed from the opening with chamfered to the current position indicated in Figure 5-14.

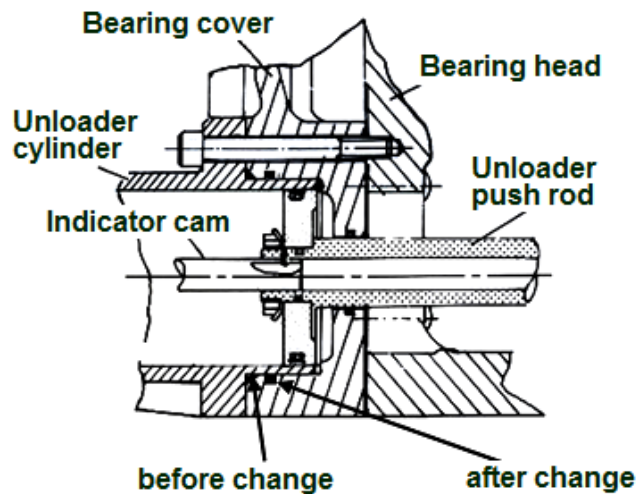

Figure 5-14 Change of The O-ring position for Bearing cover

- e) Attach the unloader cylinder to the bearing cover (Photo 109), and fasten the eight hexagon socket head cap screws [62-1] to the specified torque (50 N·m).



Photo 107



Photo 108



Photo 109

- f) Attach the lock washer [70-1] and lock nut [69-1] to the unloader push rod, and fasten the lock nut to the specified torque of 120 N·m (Photo 110). To stop rotation, align the lock washer tooth with the notch of the lock nut in the tightening direction, and bend the tooth (Photo 111). Lastly, check the movement of the unloader piston by using eye bolts.



Photo 110



Photo 111

### CAUTION

- For the 2016MSC and 2016MMC, be sure to install the unloader piston spacer [423] with the O-ring [702] to the low-stage unloader cylinder (refer to Chapter 7, Figure 7-9 and Figure 7-11 in this manual).

### 5.5.13 Shaft Seal Block

The standard mechanical seal assemblies used in the current shaft seal of **MYCOM** standard screw compressors are of the BBSE (balance bellows single) type.

In addition, the BOS (balance O-ring single) type mechanical seal assembly may be used depending on the specifications of the customer.

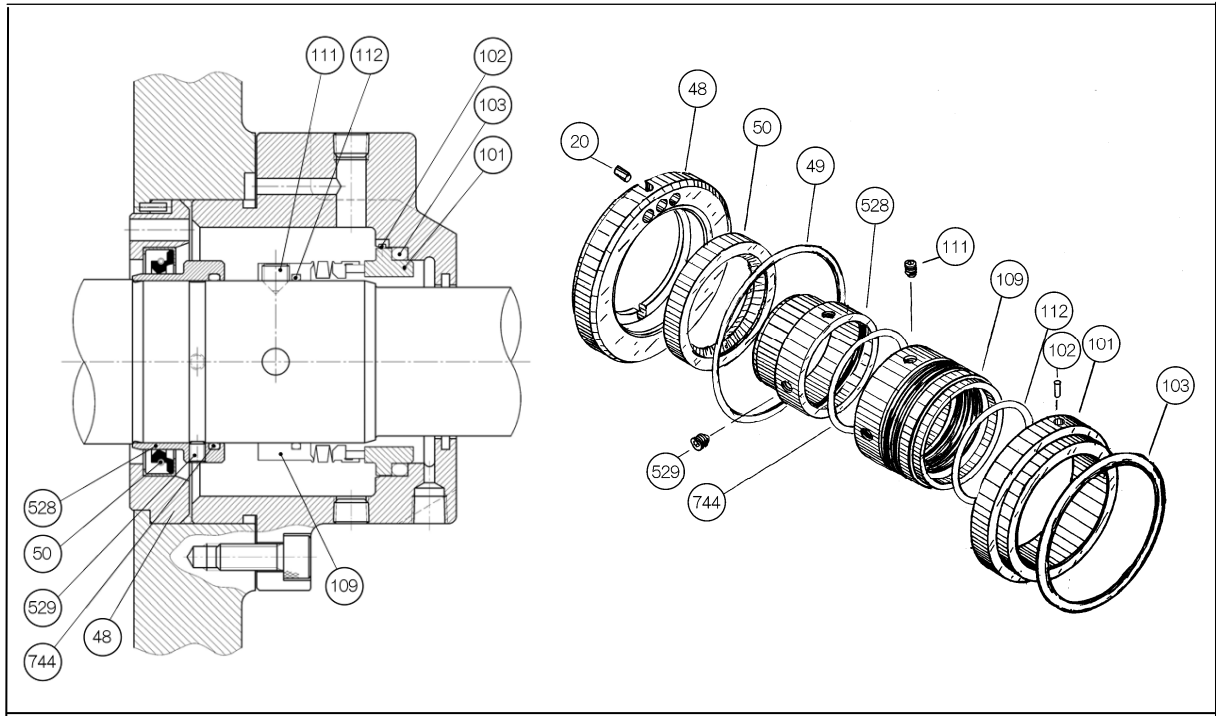

**Figure 5-15 BBSE Type Mechanical Seal Assembly and Related Parts**

- a) Before assembly, clean the portion where the rotor shaft seal will be installed.
- b) In particular, recheck immediately before assembly that the axial stepped portion where the ~~axial~~ seal will be mounted is free of damage.
- c) Attach the oil seal [50] to the oil seal retainer [48].  
The installation orientation of the oil seal has been reversed in November 2002 as a design change. While the oil seal had been installed with the oil seal lip facing the direction of the atmosphere, the direction was reversed. This is because excessively high pressure should be avoided by helping the escape of oil from the seal box.  
Using a Teflon block or the like as a pad, lightly hit the pad to push the oil seal evenly into the retainer until it is fully seated. Once the oil seal is fully inserted, you can easily sense it as the hitting sound as well as the response will change.  
After assembly, check that the step formed at the boundary between the oil seal and the retainer is even. See from the opposite side, and confirm that they are evenly assembled.
- d) Insert the O-ring [744] in the inner periphery of the oil seal sleeve [528], which should then be attached to the oil seal retainer with oil seal inserted (Photo 112).



- e) Install the oil seal retainer, which has oil seal and sleeve attached, along the rotor shaft by using two standard M8 eye bolts (as shown in Photo 113). At this time, ensure that the retainer's oil hole is on the upper side of the rotor shaft, and accurately align the rotation stop spring pin [20], which has been screwed to the bearing cover, with the notch of the oil seal retainer. After assembly, try to slightly turn the retainer's eye bolts to check that they are secure. If they are properly aligned, the retainer will not rotate.
- f) Secure the oil seal sleeve to the rotor shaft by using two set screws [529] (Photo 114).

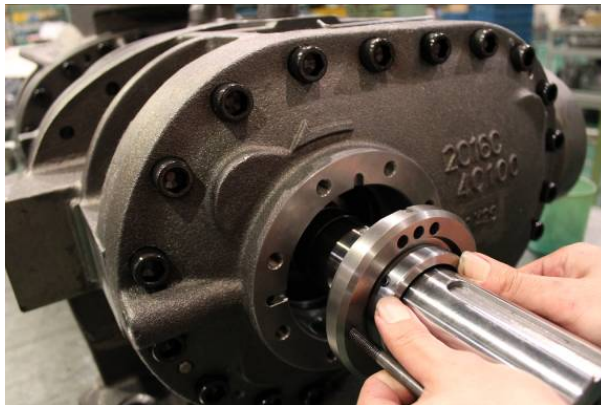

Photo 113



Photo 114

- g) Then, insert the O-ring [49] for the oil seal retainer (Photo 115).

CAUTION
<ul style="list-style-type: none"><li>● You should be particularly careful on this point, as the O-ring for the oil seal retainer [49] is often forgotten to be installed.</li></ul>



Photo 115

- h) Install the seal collar [109], which has the O-ring [112] attached to its inner periphery, to the rotor shaft. Before assembly, apply sufficient lubricating oil onto the rotor shaft and wash away dirt. Push in the seal collar, carefully not to damage the O-ring [112] by the step on the rotor shaft (Photo 116). After installing the seal collar, push it by hand and check its normal movement in the axial direction.
- i) Fasten the seal collar on the rotor shaft by screwing the two seal collar set screws [111] at the countersinks on the rotor shaft (Photo 117). Failing to fasten the screws at the countersink positions will damage the rotor shaft, and it can cause a leakage.



Photo 116



Photo 117

- j) Attach the O-ring [103] for mating ring and mating ring [101] to seal cover [51] (Photo 118).
- k) Apply oil to the seal cover gasket [52], align the gasket oil hole with the oil hole on the seal cover flange surface, and affix the gasket.

\* With the standard internal oil supply type compressors, the bearing cover and the seal cover are connected by an oil supply hole. Oil flows from the notch in the seal cover through the groove to the upper side of the seal cover, and then flows through the drilled oil supply hole to the upper sliding surface of the mechanical seal.

- m) Install the seal cover with the gasket, so that the oil drop pipe of the seal cover is on the bottom side. At this time, assemble it carefully, either at a right angle or by delaying the upper side slightly, while paying attention not to cause the mating ring inside the seal cover hit against the rotor shaft (Photo 119).



Photo 118



Photo 119

- n) The seal ring and the mating ring sliding surface will come into contact midway through attachment. At this moment, check the dimensions between the seal cover gasket and the bearing cover flange surface by using a taper gauge (Photo 120). This value is called "fastening margin" for seal.

It is used when checking the sliding face pressure between the rotating ring and stationary ring of the seal. In case of BBSE-type seal of the 2016\*\*C, make sure that this value is in the range of 2 to 3 mm.

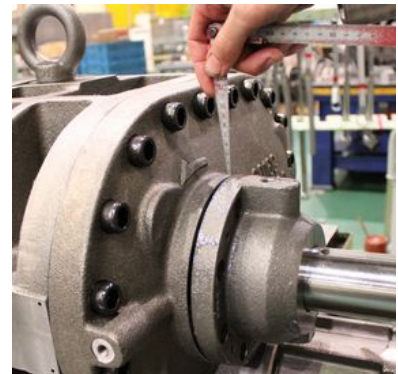

Photo 120

- o) When the seal fastening margin is proper, push the seal cover firmly into the bearing cover. Since there is repulsion force of the seal bellows, keep it pushed firmly and tighten the two hexagon socket head cap screws [53] (for tightening the seal cover) evenly at positions 180 degrees apart. When there is no gap between the flange surface and the gasket, tighten all of the remaining bolts to the specified torque (50 N·m).

- p) After fastening the seal cover, remove the plug on the top of the seal cover, and supply oil approx. 200 mL into the seal cover while rotating the rotor shaft (Photo 121).

This oil refilling work is very important to maintain the airtightness in the shaft seal block when vacuuming after compressor overhauling.

After the refilling work, make sure to attach the removed plug on the seal cover.



Photo 121

## 5.5.14 Unloader Cover

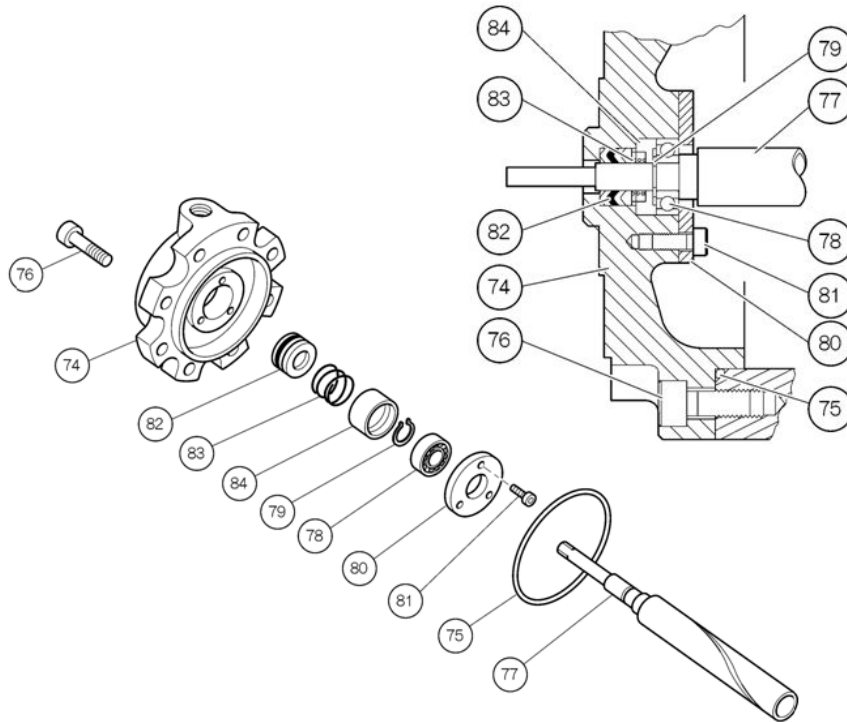

Figure 5-16 Unloader Cover Block

- a) Attach eye bolts to the unloader piston, and move it back and forth. Check once again that it functions properly. During this manual check, pay attention not to let the piston reach the utmost front position.

### CAUTION

- **With some model (2016MSC), the slide valve may come off the guide block if you pull the low-stage unloader piston excessively toward you.**

- b) Attach the ball bearing [78] to the shaft of the indicator cam [77]. When fitting, push the inner race of the bearing. Pushing the outer ring may damage the bearing. Push the bearing to the stepped portion of the indicator cam and retain the bearing with the external snap ring.
- c) Apply sufficient oil to the unloader cover [74], and attach the V-ring set [82]. One of the V-rings in a set is made of rubber (dark color) to improve sealing performance. As shown in Figure 5-16, it is set at the second position viewed from the outer side of the machine. Set the V-ring in such a way that its ridge faces the machine's outer side and the lip faces the inner side.
- d) Install the spring [83] and spring retainer [84] into position. Then insert the shaft of the indicator cam, which has been assembled in step b) above, into the V-ring. Fasten the bearing to the unloader cover by using the bearing gland [80].
- e) After making sure that the indicator cam rotates smoothly, attach the O-ring [75] to the unloader cylinder cover.
- f) Attach the unloader cover to the unloader cylinder [60]. Push the unloader cover in such a way that the guide pin [68] of the unloader push rod [67] just fits to the spiral groove of the indicator cam. Secure the unloader cover with the hexagon socket head cap screws [76], with its hole for supplying unloader working oil facing upward.



## 5.5.15 Unloader Indicator

The unloader indicator contains micro-switches, a micro-switch cam and a potentiometer. Either of them detects the rotational volume change of the shaft of the indicator cam, which converts the axial positional change of the unloader slide valve into circumferential positional change, and sends it as electric signals to the control side of the package unit or refrigerating system.

For confirmation after inspection/adjustment or parts replacement, they need to be linked with the control side. So, even during an overhaul which is conducted with the compressor carried out of the installation site, this portion is often removed from the compressor as an indicator assembly so that inspection/adjustment or parts replacement can be conducted at the site.



- **When removing or inspecting/adjusting the indicator assembly, be sure to turn off the control power and conduct lockout/tagout. Failure to turn off the power supply could cause an electric shock.**

The 2016\*\*C model has, on its high-stage, an indicator which is designed for the standard-type single-stage compressor (however, the dial face and micro-switch cam are exclusively designed for the 2016\*\*C high-stage). On the low-stage, it has an indicator designed for the low-stage of 2-stage compressor, which, additively, has bevel gears for changing the indicator dial needle and dial from axial direction to lateral direction. The basic functions and inspection procedures are common to both. So, the following explanation is given based on the standard-type high-stage unloader indicator.

### 5.5.15.1 Potentiometer

The potentiometer of the standard-type indicator is of the full rotation type. It senses the continuously variable position (indicated load of 0 % to 100 %) of the unloader slide valve, and feeds the sensed position as electric signals to the control side of the package unit or refrigerating system.

While the expected service life of the potentiometer will significantly vary depending on the installation environment of the compressor (e.g. corrosive gas atmosphere, moisture, or the like.) and operational conditions (e.g. frequent partial load operations, frequent start/stop operation, vibration, etc.), the potentiometer is a consumable part that requires regular replacement according to the situation.

#### ■ Disassembly

- a) Turn off the control power and conduct lockout/tagout. After that, remove the indicator cover [146], indicator glass [141] and indicator glass spacer [142].
- b) Remove the philips screw [140] securing the indicator dial needle [139] to the shaft.
- c) Remove the indicator dial screws [138] securing the indicator dial [137] to the dial supports.
- d) Remove the electric wiring of the potentiometer. To avoid future assembly errors, put markings to indicate positional relationship of wiring by using different colors of tape or the like, and take a note.
- e) The potentiometer set-plate [130] is fitted between the potentiometer support arms [1] [134] and arms [2] [135]. Loosen and remove the arms [2] by turning them counterclockwise while holding the arms [1].
- f) When the right and left support arms are removed, the potentiometer [129] can be removed together with the potentiometer set-plate.
- g) The potentiometer is secured to the potentiometer set-plate with three philips screws.

#### ■ Inspection

- a) On the terminal block, check whether or not the lead wires of the potentiometer are loose.
- b) Check for defects such as cracks in the welded portion of the potentiometer lead wires.
- c) Rotate the axis of the potentiometer with hand, and check with a circuit tester whether the resistance value changes smoothly.

#### ■ Reassembly

To reassemble the unloader indicator, follow the disassembly procedure in reverse.

### 5.5.15.2 Micro-switch and Micro-switch Cam

The standard-type unloader indicator has two micro-switches and one micro-switch cam, for sensing that the unloader slide valve is at the 0 % position or the 100 % position of capacity control (indicated load). If, for any reason, their assembly gets loose or the micro-switch(es) gets faulty, proper sensing will be disabled, which will cause trouble in operation control of the compressor.

#### ■ Disassembly

- a) Turn off the control power and conduct lockout/tagout. After that, remove the indicator cover [146], indicator glass [141] and indicator glass spacer [142].
- b) Remove the philips screw [140] securing the indicator dial needle [139] to the shaft.
- c) Remove the indicator dial screws [138] securing the indicator dial [137] to the dial supports.
- d) Remove the electric wiring of the micro-switch. To avoid future assembly errors, put markings to indicate positional relationship of wiring by using different colors of tape or the like, and take a note.
- e) The micro-switch [125] is secured with two long philips screws [126]. The micro-switch can be removed by loosening these screws. Do not remove these screws except when the micro-switch needs to be replaced. Leave them as they are when conducting inspections or positional adjustments.
- f) The micro-switch on the right is for sensing the no-load (0 %) position and the micro-switch on the left is for sensing the full-load (100 %) position.  
Under the left micro-switch, the micro-switch base plate [123] is secured with different philips screws [124] on the micro-switch mounting frame. This is to use the cam which is outside the micro-switch cam [127].

#### ■ Inspection

- a) In a normal state where the compressor's capacity control oil pressure pipe is not opened, pull the unloader piston to the no-load position/full-load position by using the manual capacity control circuit, in order to check, through the control circuit (operation check of related relays and/or contacts), whether the micro-switch senses the 0% /100% position of the micro-switch cam.
- b) Turn off the control power, and conduct lockout/tagout. After that, remove the indicator glass and check for looseness of the philips screw for securing the micro-switch [126].
- c) Check for looseness of the set screw for securing the micro-switch cam [127].
- d) Check that the wiring of the micro-switch has been removed. After that, turn the switch on and off and check whether it works properly by using a tester.
- e) When the compressor's capacity control oil pressure pipe is opened due to overhaul or the like, pull the unloader piston to the no-load position/full-load position by using nitrogen gas or compressed air pressure, in order to check whether the micro-switch senses the 0 %/100 % position of the micro-switch cam.
- f) In addition, conduct appearance check to find out any traces of water entry inside the indicator, defects in the switch terminal such as corrosion, wear in the switch roller or micro-switch cam, etc.

### 5.5.15.3 Reassembly

To reassemble, follow the inspection procedure in reverse. Lastly, position the indicator dial needle correctly by following the procedure below.

- a) When the compressor's capacity control oil pressure pipe is opened due to overhaul or the like, pull the unloader piston to the no-load position by using nitrogen gas or compressed air pressure. Then, align the indicator dial needle to the start point of the semicircular range drawn on the dial face, and fix it. Next, move the unloader piston to the full-load position, and check that the indicator dial needle points at the end point of the range drawn on the dial face.

- b) In a normal state where the capacity control oil pressure pipe is not opened, move the unloader piston by using a manual capacity control circuit. When the control power is turned on, keep the indicator cover attached to avoid electrical shock. After the position of the piston is determined, turn off the control power and conduct lockout/tagout. After that, remove the indicator cover and fix the indicator dial needle.

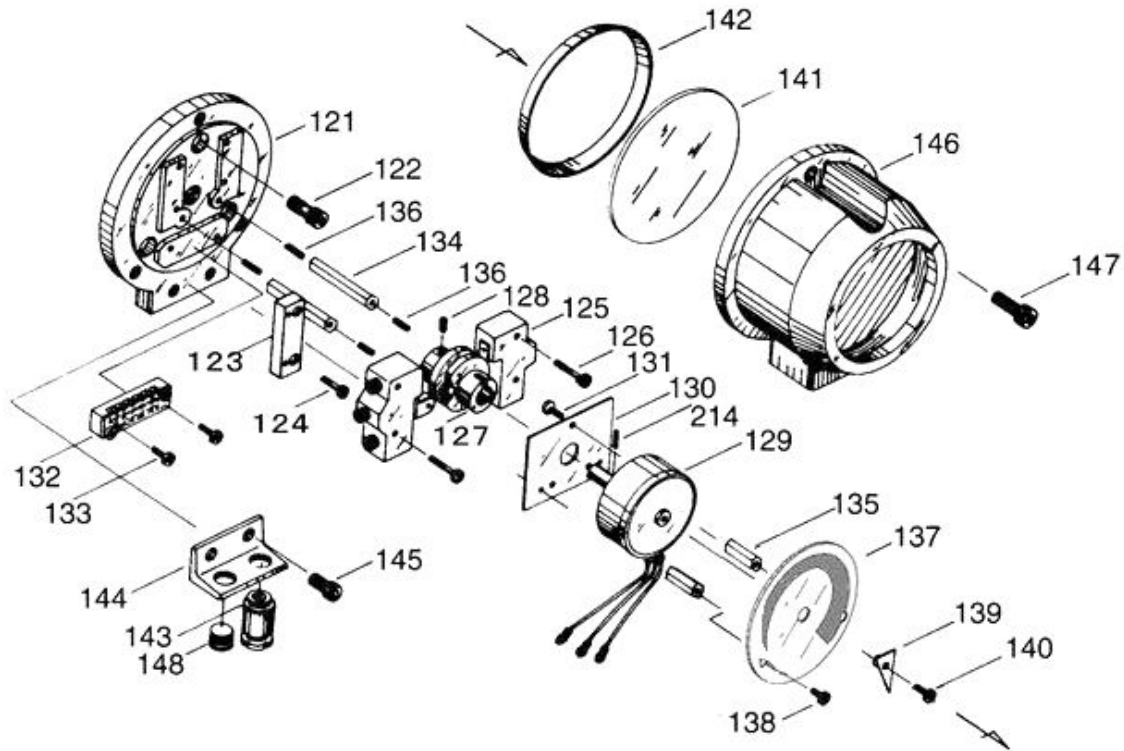

Figure 5-17 2016\*\*C Standard-type High-stage Unloader Indicator

Table 5-11 Unloader Indicator Components (Standard type)

No.	Part name	Qty.	No.	Part name	Qty.
121	Micro-switch base plate	1	136	Potentiometer mounting screw	3
122	Hexagon socket head cap screw	3	137	Indicator dial	1
123	Micro-switch set plate	1	138	Indicator dial screw	2
124	Philips screw	2	139	Indicator dial needle	1
125	Micro-switch	2	140	Philips Screw	1
126	Philips screw	4	141	Indicator glass	1
127	Micro-switch cam	1	142	Indicator glass spacer	1
128	Set screw	1	143	Electric wiring connector	1
129	Potentiometer	1	144	Connector support	1
130	Potentiometer set-plate	1	145	Hexagon socket head cap screw	2
131	Philips screw	3	146	Indicator cover (2)	1
132	Terminal block	1	147	Hexagon socket head cap screw	3
133	Philips screw	2	148	Plug	1
134	Potentiometer support arm [1]	2	214	Spring pin	1
135	Potentiometer support arm [2]	2	265-2	Spring washer	7

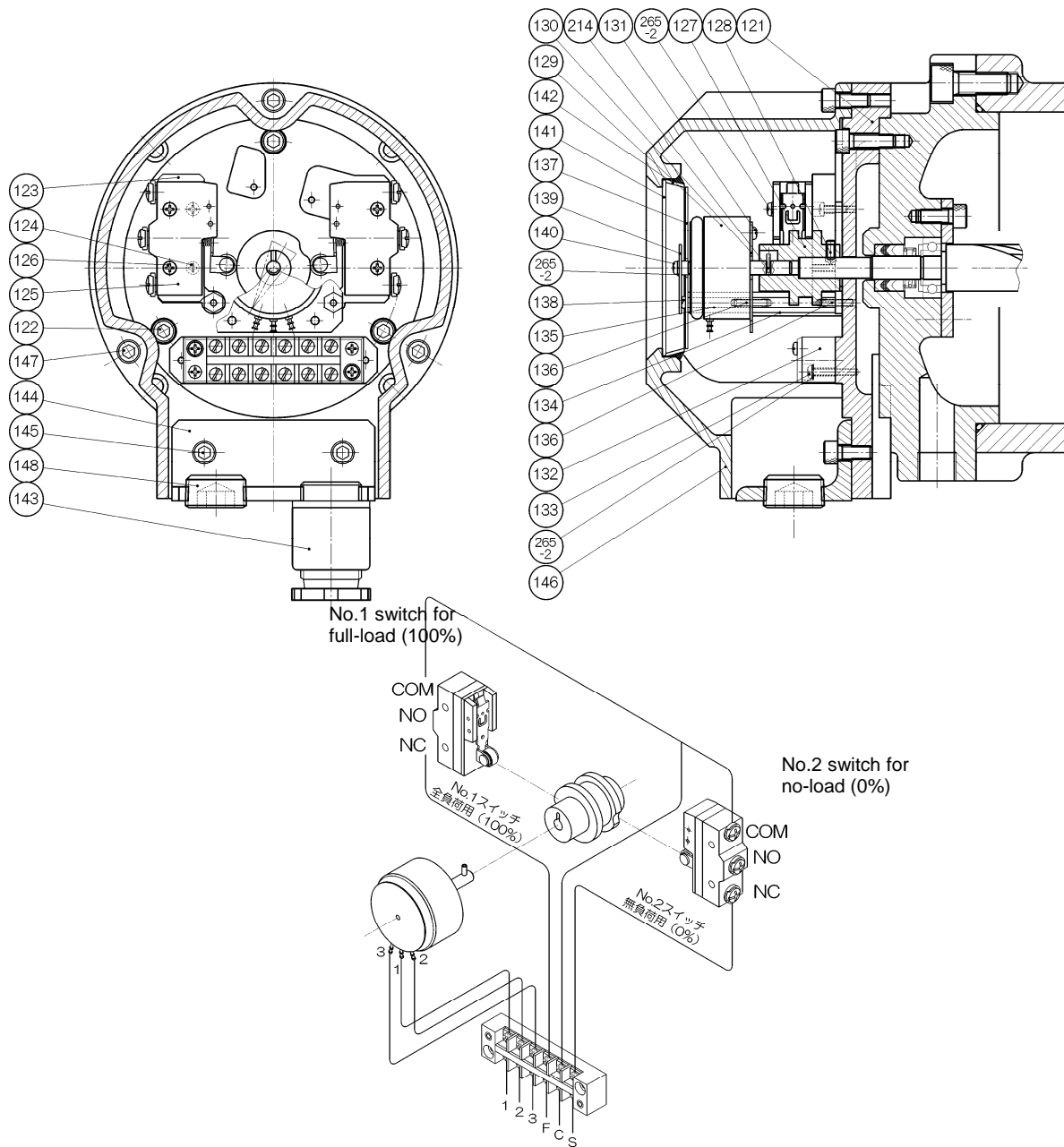

Table 5-18 Assembly Drawing of Unloader Indicator (Standard type)

## Chapter 6 Troubleshooting

Table 6-1 describes typical trouble symptoms of compressors, their causes and actions to be taken. The explanations of this Chapter are assumed that the compressor is used in the general refrigeration cycle.

Table 6-1 Troubleshooting

### 01: Compressor does not start up

Direct cause	Root cause	Action
Power source is off.	Mostly caused by forgetting to turn on after inspection.	Use a check sheet for post-inspection actions and implement finger pointing and call check to prevent forgetting.
Main motor failure	Mostly caused by activation of overload protection circuit.	Refer to the operation manual of the motor for details including other causes and actions.
"Micro-switch and micro-switch cam" of the indicator do not sense capacity control of 0%.	Micro-switch failure	Replace.
	Loosening of micro-switch or micro-switch cam set screw due to vibration.	Adjust the position of the cam and switch, and tighten them. Use thread locking agent when necessary. When compressor's vibration is unusually high, see Item No. 12 "Compressor generates abnormal vibration and/or sound".
Defective capacity control oil supply line	Improper adjustment of oil flow control valve (throttled excessively).	Readjust.
	Leak/clogging in piping or solenoid valve	Remove cause, and check oil for contamination/replace oil.
Oil pressure not detected	Failure of oil pressure protection device, pressure sensor, relay, etc.	Identify defective devices, investigate causes of failure and take necessary actions. Then, replace failed device(s).
	Pressure pipe is clogged.	Remove clogging, and check oil for contamination/replace oil.
Cooling water circulation is not confirmed.	Failure of devices such as cooling water pump and related circuits	Identify defective devices, investigate causes of failure and take necessary actions. Then, replace failed device(s).
	Circulation route is clogged.	Remove the clogging.
Failure of magnet, relay, etc. in compressor startup circuit	Aging degradation	Replace with new one.
	Poor installation environment	Replace ventilation fans, etc. if defective. Improve temperature, humidity and ventilation at the installation site.

### 02: Compressor stops immediately after startup

Direct cause	Root cause	Action
Low pressure protection circuit activates.	Insufficient refrigerant flow <ul style="list-style-type: none"> <li>Insufficient refrigerant</li> </ul>	To correct insufficient refrigerant, check leak, stop leak and then add refrigerant. * Also pay attention to moisture entering into the system.

**02: Compressor stops immediately after startup (continued)**

Direct cause	Root cause	Action
Low pressure protection circuit activates.	Insufficient refrigerant flow <ul style="list-style-type: none"> <li>Insufficient liquid supply</li> </ul>	To correct insufficient liquid supply, inspect expansion valve and liquid supply strainer. Take necessary actions. In addition, inspect devices and parameters (set values) of the expansion valve aperture adjusting mechanism, and take necessary actions.
	Heat exchange failure in heat exchanger	If there are any problem (insufficiency) in heat exchange, such as malfunction of defrosting, investigate the cause and take necessary actions. In case of malfunction of pressure control valve, replace the valve or remove the cause.
	Failure of low pressure protection device, pressure sensor, relay, etc.	Identify defective devices, investigate causes of failure and take necessary actions. Then, replace failed device(s).
Motor overload	Motor overload that occurs just after startup is mostly caused not by the refrigeration cycle but by the motor. Refer to the instruction manual of the motor.	

**03: Unusually low pressure (decrease of suction pressure)**

Direct cause	Root cause	Action
Refer to direct cause, "Low pressure protection circuit activates", in Item 02 above.	Same as left	Same as left

**04: Low oil pressure (low lubricating oil supply pressure)**

Direct cause	Root cause	Action
Oil filter element is clogged. * Pressure difference between the outlet port and inlet port is large.	Contamination of lubricating oil	Remove clogging, and check oil for contamination/replace oil.
	Internal defects of compressor	Check for oil contamination and conduct vibration/noise diagnosis. Overhaul compressor if necessary.
Insufficient oil in oil separator.	Oil heater is not functioning, refrigerant dissolves excessively when the machine is stopped, and oil loss occurs at startup.	Inspect oil heater alone, inspect relays, etc. on related circuits, and replace parts as necessary.
	Insufficient oil return due to insufficient refrigerant circulation	Correct insufficient refrigerant circulation, and return oil from load-side heat exchanger. * Supply lubricating oil temporarily.
	Troubles such as clogging in oil return passage	Remove causes of the trouble, and restore the system.

**04: Low oil pressure (continued)**

Direct cause	Root cause	Action
Insufficient oil in oil separator.	Extensive oil leak	Inspect machine room and around the compressor, and take necessary actions. Check if there is oil floating in cooling water system. →If there is, check for oil leak from heat transmission tube of oil cooler and take necessary actions.
		If piping is damaged due to excessive vibration, take measures to reduce vibration (including measures for resonance vibration).
Oil pressure detection function is defective.	Failure of oil pressure protection device, pressure sensor, relay, etc.	Identify defective devices, investigate causes of failure and take necessary actions. Then, replace failed device(s).
	Pressure pipe is clogged.	Remove clogging, and check oil for contamination/replace oil.

**05: Intermediate pressure is unusually high.**

Direct cause	Root cause	Action
High suction pressure	Heat load on load side is higher than design value.	Inspect the conditions on load side (warehousing volume, opening/closing of doors, etc.), and take necessary measures.
	Malfunction of suction pressure control mechanism	In case of pressure sensing failure, replace the pressure sensor. * In some cases, pressure pick-up position is improper. → Change the position.
		If there is a problem in device(s) on the control circuit, find the defective device(s) and replace it.
		If parameter (set value) on the control circuit is improper, optimize it.
		In case of malfunction of pressure control valve, replace the valve or remove the cause.
Malfunction of compressor's capacity control	See Item No. 11 "Capacity control malfunction".	
Liquid flow-back from intermediate liquid cooler.	Failure or internal leakage of intermediate liquid supply expansion valve	Repair or replace.
There is problem in compressor's high-stage.	Malfunction of capacity control on compressor's high- stage	See Item No. 11 "Capacity control malfunction".
	Excessive wear or sliding damage of the part(s) on compressor's high- stage	Overhaul compressor and replace parts. Replace the whole quantity of lubricating oil.

**06: Unusually high pressure (abnormal discharge pressure)**

Direct cause	Root cause	Action
Heat exchange failure in condenser (heat exchanger)	Heat transmission tubes and/or fins are contaminated or blocked.	Clean and wash. Depending on the contamination level, use chemical cleaning.
	Failure or water dripping in fan motor, thermo switch, water spraying pipes, cooling water pumps, etc.	Identify defective devices, investigate causes of failure and take necessary actions. Then, replace failed device(s).
	Faulty adjustment of cooling water/brine	In case of manually adjusted valve, readjust the valve. When an automatic control valve (including wax valve) is used, investigate the cause and take necessary actions.
	Other causes of insufficient flow of cooling water, etc.	Inspect filters installed on the circulation route for clogging and contamination, and take necessary actions. Inspect for leaks in circulation routes, and take necessary actions. Inspect water supply routes/mechanisms, and take necessary actions. If frozen, take measures such as improvement of heat insulation or increase of temperature.
	Deficiency in heat exchanger performance	If the symptom is caused by change in operating conditions, re-examine the conditions for improvement. If the symptom is caused by change in installation environment, improve the environment if possible. In either case, if improvement measure is difficult to be made, add more heat exchangers or increase their sizes.
Non-condensable gases mixed into the system	Leak on low pressure side * There are also cases where the symptom was caused by corrosion in suction temperature gauge protection	Perform a leak check, and take necessary measures. Air-purge the heat exchanger.
Refrigerant is excessive.	In some cases, insufficient cooling is judged as caused by insufficient refrigerant and, as a result, refrigerant is charged repeatedly.	Properly adjust the refrigerant charge.
	Capacity of heat changer is insufficient.	If the symptom is caused by change in operating conditions, re-examine the conditions for improvement. If improvement is difficult, add heat exchangers or increase their sizes.



**06: Unusually high pressure (continued)**

Direct cause	Root cause	Action
Discharge pressure detection function is defective.	Failure of high pressure protection device, pressure sensor, relay, etc.	Identify defective devices, investigate causes of failure and take necessary actions. Then, replace failed device(s).
	clogging of pressure pipe	Remove clogging, and check oil for contamination/replace oil.
Outlet shut-off valve of oil separator is closed.	Operator forgot to restore after shut down operation. Human error	Open the valve or perform emergent stop. Be sure to conduct tagout while handling valves. Be sure to check valves before starting the compressor.

**07: Discharge temperature is abnormally high.**

Direct cause	Root cause	Action
Overheated during operation	Insufficient refrigerant flow	See the causes listed in item 02 above.
	Heat load on load side is higher than design value.	Inspect the conditions on load side (warehousing volume, opening/closing of doors, etc.), and take necessary measures.
	Failure of low pressure protection device, pressure sensor, relay, etc.	Identify defective devices, investigate causes of failure and take necessary actions. Then, replace failed device(s).
Non-condensable gases mixed into the system	Leak on low pressure side	Perform a leak check, and take necessary measures. Air-purge the heat exchanger.
Oil supply temperature is high.	Heat exchange failure in oil cooler	For water-cooling system, see "Heat exchange failure in heat exchanger" in 06 above. For liquid cooling system, check liquid supply expansion valve, temperature sensor and related relays/wiring/terminals, and take necessary actions.
	Oil temperature rise protection feature does not function.	Check temperature protection device, temperature sensor and related relays/wiring/terminals, and take necessary actions.
Defective discharge temperature detection/protection feature.	Failure of temperature protection device, temperature sensor, relay, etc.	Identify defective devices, investigate causes of failure and take necessary actions. Then, replace failed device(s).
Insufficient oil supply	See "Low oil pressure" in Item 04 above.	Same as left

**08: Leak from mechanical seal**

Direct cause	Root cause	Action
Initial leak after replacement until sliding surfaces settle	In some cases, immediately after replacement, the compressor-specific operating conditions and the pressure receiving conditions of machined sliding surface is unstable.	In case of initial leak, although leak amount might increase temporarily, it will decrease gradually. Check that leak does not increase continuously. Duration of initial leak depends on design/operating conditions. It is approximately 200 hours, as a rough indication.
Sliding surface is roughened due to overheating.	Started and stopped too many times. * In case of standard equipment, "four or more times per hour" is considered "frequent/too many".	If heat load is less than the level set by the equipment's design conditions, review the operating conditions and set control such that equipment is started/stopped less frequently. In case of capacity control malfunction, see "Capacity control malfunction" in item No. 11.
	Excessive refrigerant solved into the lubricating oil, resulting in decreased viscosity of oil.	In case of liquid flow-back, remove the cause(s). If oil heater or devices on its control circuit are defective, replace the defective part.
	Overheated operation	See the causes in item 02, "Insufficient refrigerant flow".
	Oil supply temperature is high.	See the causes in item 07, "Oil supply temperature is high".
Machine is stopped for a long time. (No oil film on sliding surfaces)	User-specific conditions, such as intermittent heat load	If machine is sometimes stopped longer than a week, take either of the following measures: (i) Manually operate oil pump alone and turn the rotor shaft of the compressor. (ii) Attach an oil pot for supply oil to the seal cover.
Deteriorated part(s)	Hardened O-ring	If deteriorated over time, replace. For other specific causes, see the causes/action for symptom "Overheating of sliding surface".
	Swelled O-ring * This occurs when the lubricating oil of refrigerating machine contains large amount of refrigerant.	In case of liquid flow-back, remove the cause(s). If oil heater or devices on its control circuit are defective, replace the defective part.
	Deteriorated seal ring/mating ring	If deteriorated over time, replace. For other specific causes, see the causes/action for symptom "Overheating of sliding surface".
Incompatibility of lubricating oil and operating conditions (such as working temperature range or refrigerant)	Unsuitable lubricating oil was selected, or operating conditions have changed after installation of the equipment.	If possible, review the operating conditions. If not, see "4-1 Lubricating Oil (Refrigerant Oil)" to select suitable lubricating oil and replace the whole quantity.

**08: Leak from mechanical seal (continued)**

Direct cause	Root cause	Action
Poor contact of sliding surfaces	Foreign matter attached to sliding surfaces, due to contaminated lubricating oil.	Replace the whole quantity of lubricating oil. Install bypass filter to oil supply line.
	Faulty assembly of parts Human error	Disassemble, replace parts and reassemble. Use assembly check sheet to ensure confirmation.

**09: Squeaking of mechanical seal**

Direct cause	Root cause	Action
During initial period after exchange for new mechanical seal, squeaks may be heard from sliding surfaces until they fit together.	As the sliding surfaces are very hard and dense, they need time to fit together.	Squeaking itself does not cause leak from seal or deterioration in sealing function. Normally, squeaking is heard for several dozens of hours, however, it may last longer in rare cases. →In this case, contact our service center.

**10: Capacity control position is indicated incorrectly**

Direct cause	Root cause	Action
Inaccurate reading of compressor indicator gauge.	Screw for securing indicator needle is loose.	Manually operate the compressor's capacity control to indicate 0% position, and tighten the screw again.
	Indicator's bevel gears are worn.	If deteriorated over time, replace. If the wear is caused by excessive vibration of the compressor, take measures to reduce vibration and then replace the bevel gears.
Inaccurate reading of capacity control indicator on the control panel.	The cam groove of compressor's indicator cam is worn.	Often caused by continued operation with load on a certain point. →Replace the indicator cam. * The currently shipped indicator cam has its grooved portion strengthened.
	The guide pin of the compressor push rod is worn.	Currently, this pin is also improved in resistivity against wear. If the indicator cam is replaced with the improved version, replace the pin with the countermeasure part.
	Failure of potentiometer	If the part is deteriorated over time or loaded at a certain point during operation for a long time, replace it. If the wear is caused by excessive vibration of the compressor, take measures to reduce vibration and then replace the potentiometer.
	Improper zero span adjustment of E/E positioner	Readjust.

**10: Capacity control position is indicated incorrectly (continued)**

Direct cause	Root cause	Action
Inaccurate reading of capacity control indicator on the control panel.	E/E positioner or/and indicator is faulty.	If deteriorated over time, replace. If there are specific causes such as surge current, remove the cause or take proper action.
	Loosened terminals or defective wires	Tighten the terminals if loosened. Replace defective wires.

**11: Capacity control malfunction**

Direct cause	Root cause	Action
↑ See the causes for "Inaccurate reading of capacity control indicator on the control panel".	Same as left	Same as left
"Micro-switches and micro-switch cam" of the indicator do not sense "100%" position and/or "0%" position.	Micro-switch failure	Replace.
	Loosening of micro-switch or micro-switch cam screw due to vibration.	Adjust the position of the cam and switch, and tighten them. Use thread locking agent when necessary. When compressor's vibration is unusually high, see Item No. 12 "Compressor generates abnormal vibration and/or sound".
Failure of capacity control solenoid valve or related relays	Mostly caused by coil burnout.	If deteriorated over time, replace. If the symptom is caused by wet with water, etc., remove the cause(s) and then replace defective part(s). For details, refer to the instruction manual of solenoid valve.
Internal leakage of capacity control solenoid valve	Oil compression due to temperature rise inside unloader cylinder	If the symptom is caused by long duration of low-load operation, review and improve the operating method. Arrange inline check valve and oil bypass route on the capacity control oil supply line.
Defective capacity control oil supply line	Improper adjustment of oil flow control valve	Readjust.
	Leak/clogging in solenoid valve gland or oil supply piping	Remove cause, and check oil for contamination/replace oil.
Unloader piston does not move. (Though this is one of the causes of "Defective capacity control oil supply line", it is listed separately here.)	Damage on the cap seal of the piston	Check oil for contamination/replace oil. Replace O-ring, cap seal, etc.
	Cap seal is pinched.	Replace O-ring, cap seal, etc.
	Cap seal is worn.	Check oil for contamination/replace oil. Replace O-ring, cap seal, etc.
	There is residual refrigerant gas inside unloader cylinder.	Stop the compressor. By operating the oil pump, repeat load/unload operation to purge refrigerant gas from unloader cylinder. In case of liquid flow-back, remove the cause(s). If oil heater or devices on its control circuit are defective, replace the defective part.

**12: Compressor generates abnormal vibration and/or sound.**

Direct cause	Root cause	Action
Shaft poorly aligned with motor	If the shaft vibration value of axial direction is high, it may be caused by this.	Conduct shaft alignment again. If this occurs frequently in monocoque unit, perform hot alignment (operate the compressor at rated speed to raise the temperature and make adjustment before it cools down).
M rotor shaft runout excessively.	Lock nuts and/or thrust bearing glands are tightened unevenly.	If lock nuts are not loose and parts such as thrust bearing are free of defects, tighten the glands evenly.
	Thrust bearing glands get loosened.	Lock washer tooth not bended, or thrust bearing rolling elements (balls) are worn. → Check the thrust bearing. If any defect is found, replace it, and then reassemble it after adjusting end clearance and checking shaft runout.
	Rotor dynamic balance is disturbed.	If no other causes are found for abnormal vibration, or if on-site overhaul only has been repeatedly performed for a long time, this may be the cause. → Overhaul the compressor at a place where a dynamic balance measurement/adjustment system is available, such as the MAYEKAWA Moriya Factory.
Oil compression	Continuous low-load operation with capacity control not greater than 30%	During low-load operation, lubricating oil is difficult to be discharged. As a result, oil that stays between the engaged rotors increases and gets compressed. → Avoid continuous low-load operation as far as possible. * Especially when the fluid is light gas (He, NH <sub>3</sub> , etc.), continuous operation of merely 10 minutes can cause bad effect. The maximum limit should be 30 minutes even for fluorocarbon fluids.
Liquid flow-back during startup * Loud abnormal noise at startup. * If this is heard, the compressor may get damaged instantaneously.	Refrigerant liquefies and stays inside upstream piping when equipment is stopped.	There are many probable causes, such as a leak inside liquid supply solenoid valve on the load side, insufficient heat exchange (refrigerant evaporation) in heat exchanger, or trapping due to mis-piping in the piping line. → Identify the cause(s) and take necessary measures. Then overhaul and inspect the compressor.

**12: Compressor generates abnormal vibration and/or sound (continued)**

Direct cause	Root cause	Action
<p>Liquid flow-back during operation</p> <p>* Notable frosting on the suction side.</p> <p>* In many cases, flow-back of mist (steam) rather than liquid occurs.</p> <p>* Sometimes, gas-liquid separator (accumulator) is attached to prevent this symptom.</p> <p>* See also the causes in item 02, "Insufficient refrigerant flow"</p>	Aperture of liquid supply expansion valve is large	<p>In case of temperature-type expansion valve, check the condition of temperature sensitive cylinder and capillary tube. If any defect is found, take necessary actions.</p> <p>If orifice gets unsuitable due to the change in operating conditions, replace the orifice with proper size one(s).</p> <p>In case of electronic expansion valve, check devices attached on the expansion valve aperture control mechanism (circuit) such as temperature sensor, converter, controller (overheating regulator). If any of them is found defective, replace it.</p> <p>In the same way as with temperature-type expansion valve, if orifice gets unsuitable due to the change in operating conditions, replace the orifice with proper size one(s).</p>
	Rapid change from no-load operation to full-load operation	<p>Set control parameters so as to prevent rapid changes.</p> <p>Otherwise, make adjustment by throttling the aperture of the capacity control increase-side oil quantity adjusting valve.</p>
	Expansion valve aperture control cannot keep up with rapid change in heat load on the load side.	<p>Avoid rapid change in heat load that exceeds the set value of follow-up range of "heat exchanger on load side (evaporator)" and "expansion valve".</p> <p>For details, refer to the instruction manuals related to devices/control on load side.</p>
	Heat exchange failure in heat exchanger on load side •Related to defrosting	<p>In case of frosting (icing), conduct manual defrosting.</p> <p>Set defrosting interval shorter.</p> <p>If a device which is specific to the defrosting type fails, remove the cause(s) and replace the device(s).</p> <p>If a piping route which is specific to the defrosting type gets blocked, remove the cause(s) and take necessary actions.</p> <p>* Especially when handling hot gas defrosting systems, thoroughly read and understand the contents of the instruction manuals for the units associated with devices/control on the load side.</p>
	Heat exchange failure in heat exchanger on load side •Load side conditions	<p>If ventilation around the heat exchanger is obstructed for any reason such as piled up load, improve the conditions.</p> <p>* Ensure the flow of heating medium through the heat exchanger on the load side.</p>
	Heat exchange failure in heat exchanger on load side •Heat exchanger conditions	<p>Check for any blocked heat transmission tubes or fan motor(s) failure. If any problem is found, take necessary actions.</p>

**12: Compressor generates abnormal vibration and/or sound (continued)**

Direct cause	Root cause	Action
Foreign substances entering the compressor	Welding spatter, etc. flowing from upstream side	Check suction strainer and/or oil filters. Replace element if defective. Overhaul the compressor. Collect foreign substances and identify their sources. Then take necessary actions.
	Tools and/or waste cloth left uncollected after overhauling	
Damaged thrust bearings.	Deterioration over time (operated beyond recommended time of replacement)	The time for replacement depends largely on operating conditions (low pressure or high intermediate pressure will make the life shorter, etc.) and/or oil management conditions. In case of a typical refrigeration application which basically operates in a stable continuous mode, inspect and replace them every 40,000 hours or 5 years, whichever comes first. For details, see Chapter 5, Section 5.2.3 in this manual.
	Operation with liquid flow-back	Refer to causes of "Liquid flow-back during startup" and "Liquid flow-back during operation" in item 12.
	Entry of foreign substances	Refer to causes of "Foreign substances entering the compressor" above.
	Excessive thrust stress other than above • High suction pressure/intermediate pressure exceeding the level set by operating conditions	Re-examine operating conditions, and improve if possible. If difficult to improve, review maintenance interval.
	Faulty assembly * Lock nuts tightened insufficiently, lock washer tooth not bended, rotation stopper not set to thrust bearing gland, gland not assembled, etc.	Tighten lock nuts by using specified torque or torque angle (see Chapter 7, "7.3 Tightening Torques for Bolts and Nuts" in this manual).  Be sure to record data on the assembly check sheet to prevent omission of work steps.
Resonance vibration	This occurs when the frequency of vibration comes close to the natural frequency of any component in the entire vibrating system, including pipes and supports.	In many cases, this symptom is caused by change in installation environment (such as change in piping routes or additive installation of devices in the machine room, oil level change, etc.) →If occurrence of resonance vibration is a suspected, contact our service centers.

# Chapter 7 Related Documents

## 7.1 Development Views, Assembly Sectional Views

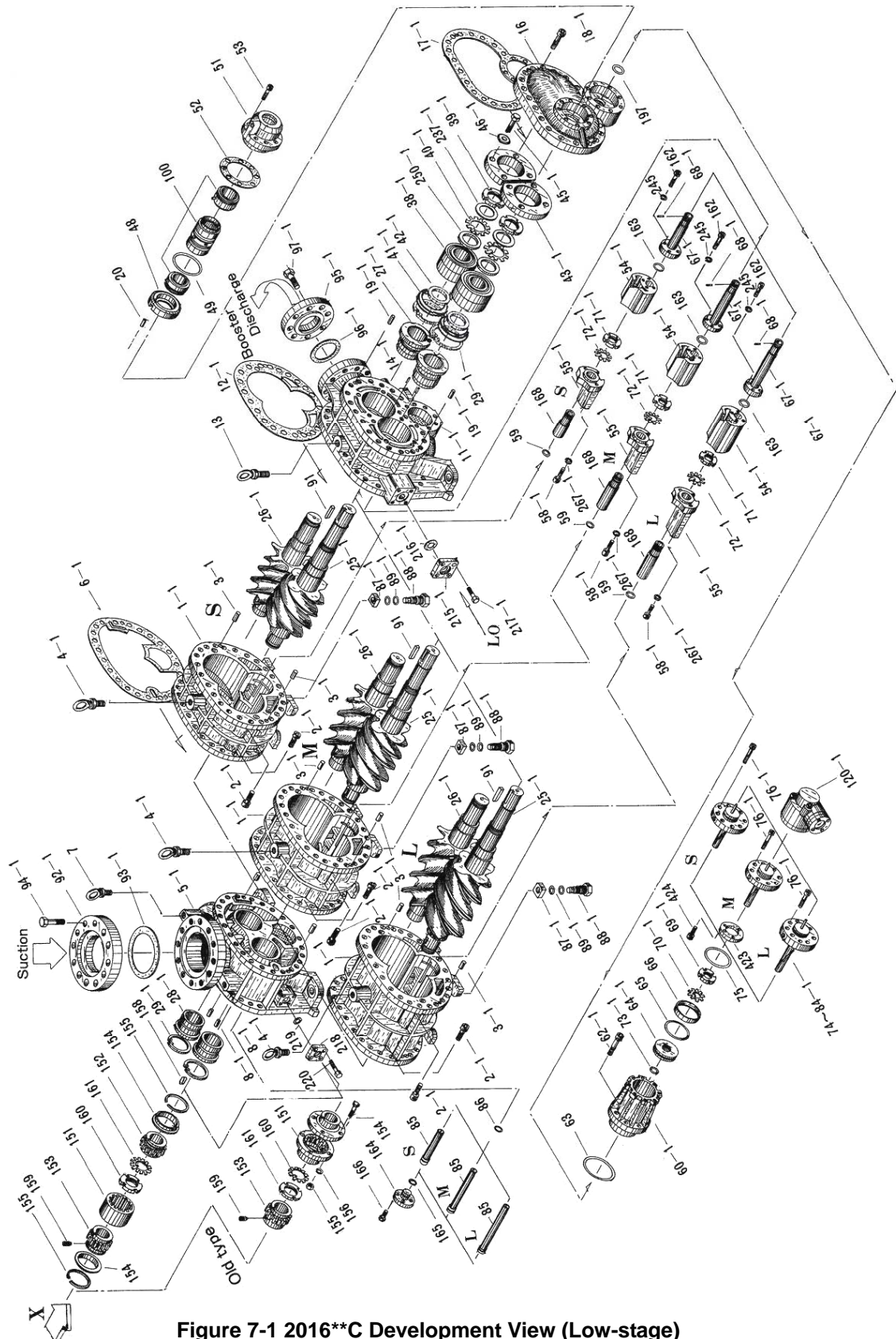

Figure 7-1 2016\*\*C Development View (Low-stage)



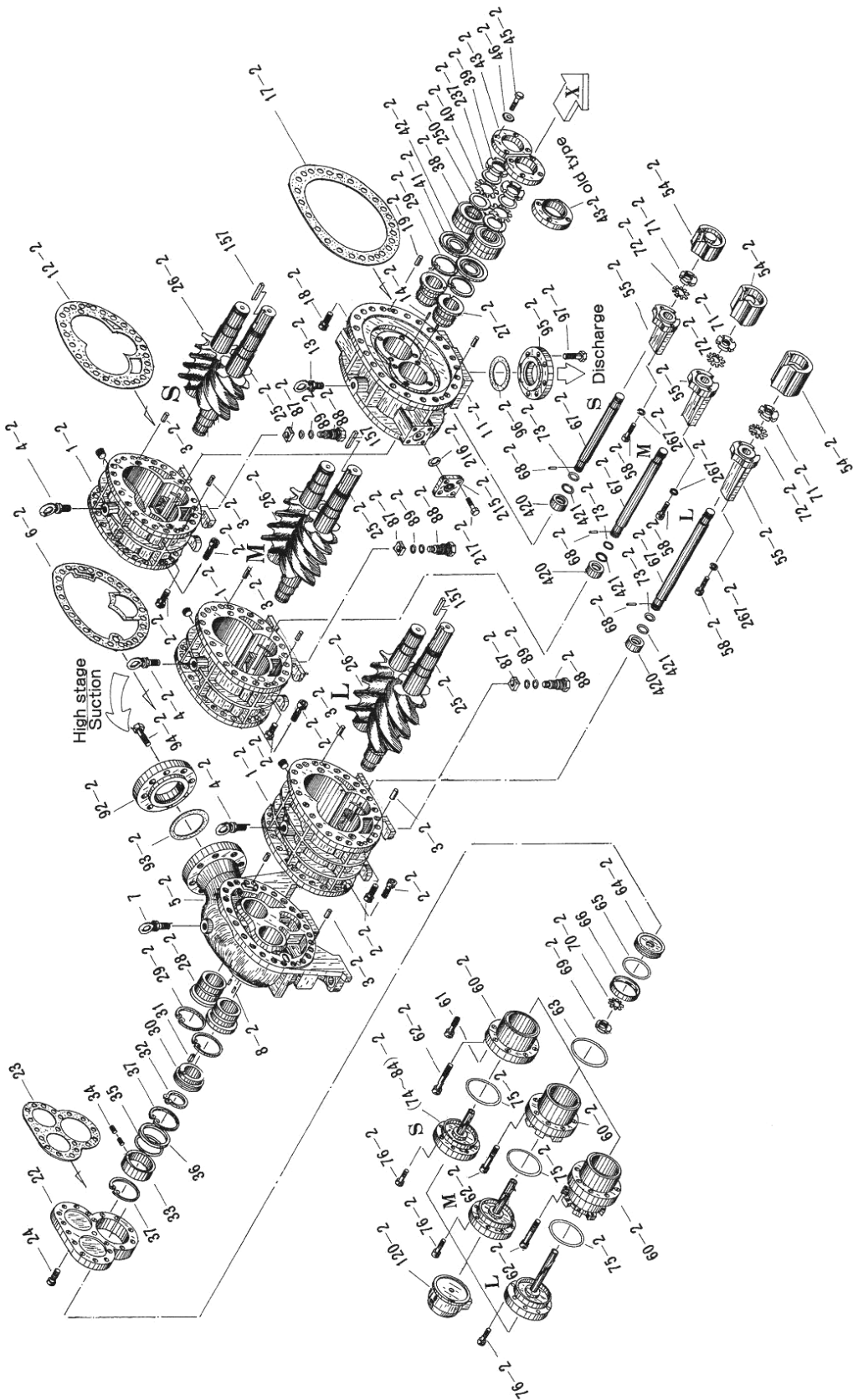

Figure 7-2 2016\*\*C Development View (High-stage)

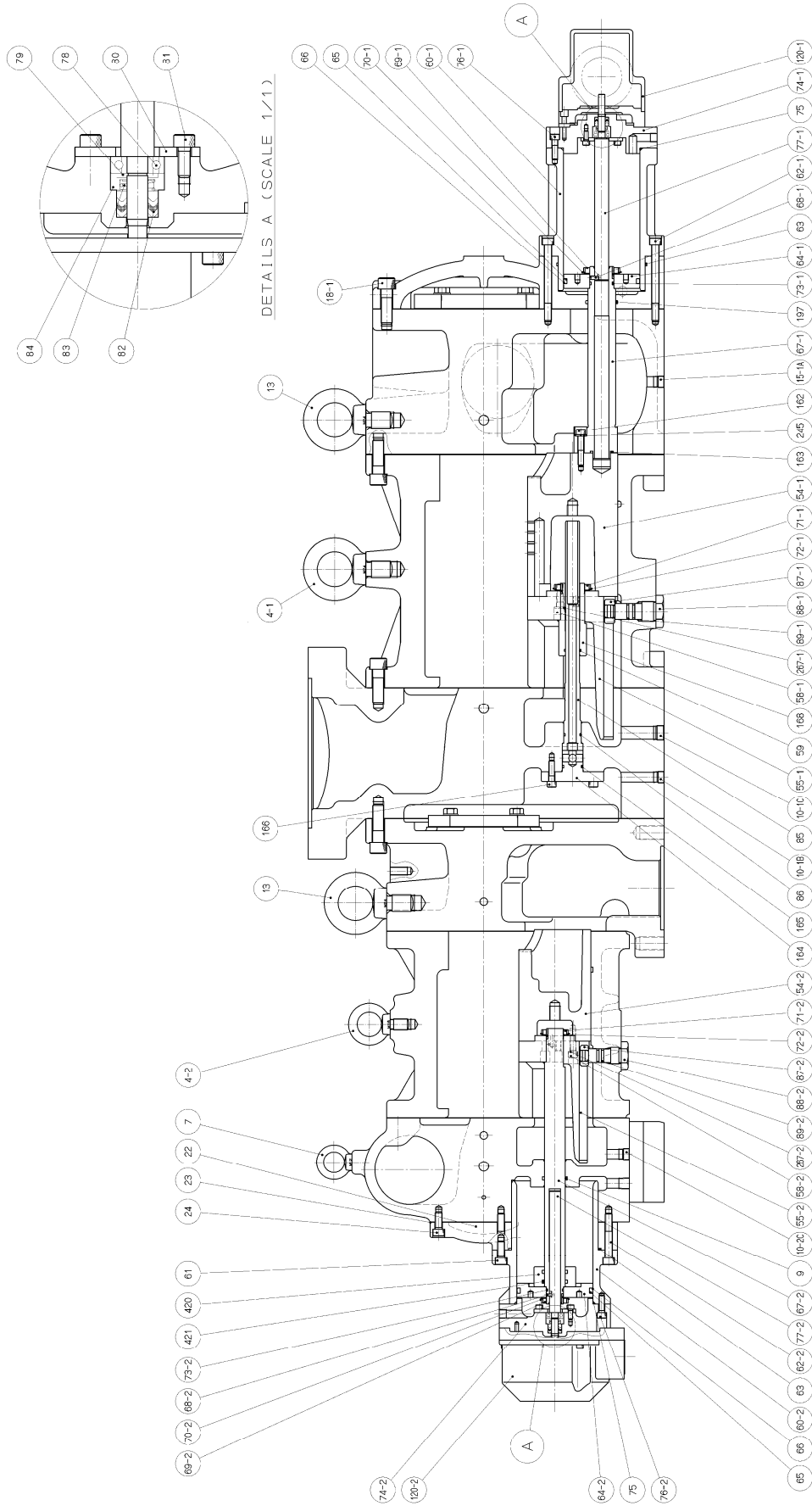

Figure 7-3 2016LLC Assembly Sectional View (Vertical)

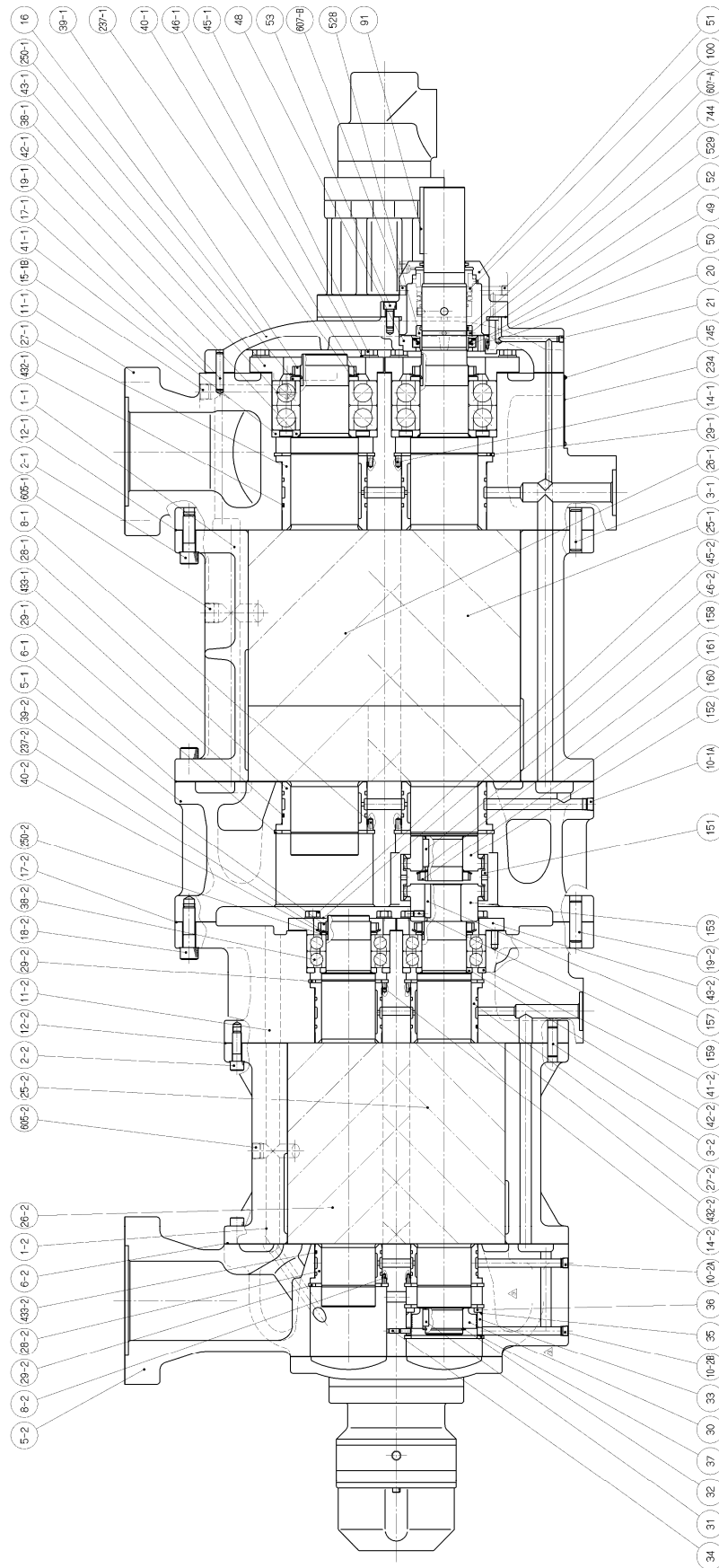

Figure 7-4 2016LLC Assembly Sectional View (Horizontal)

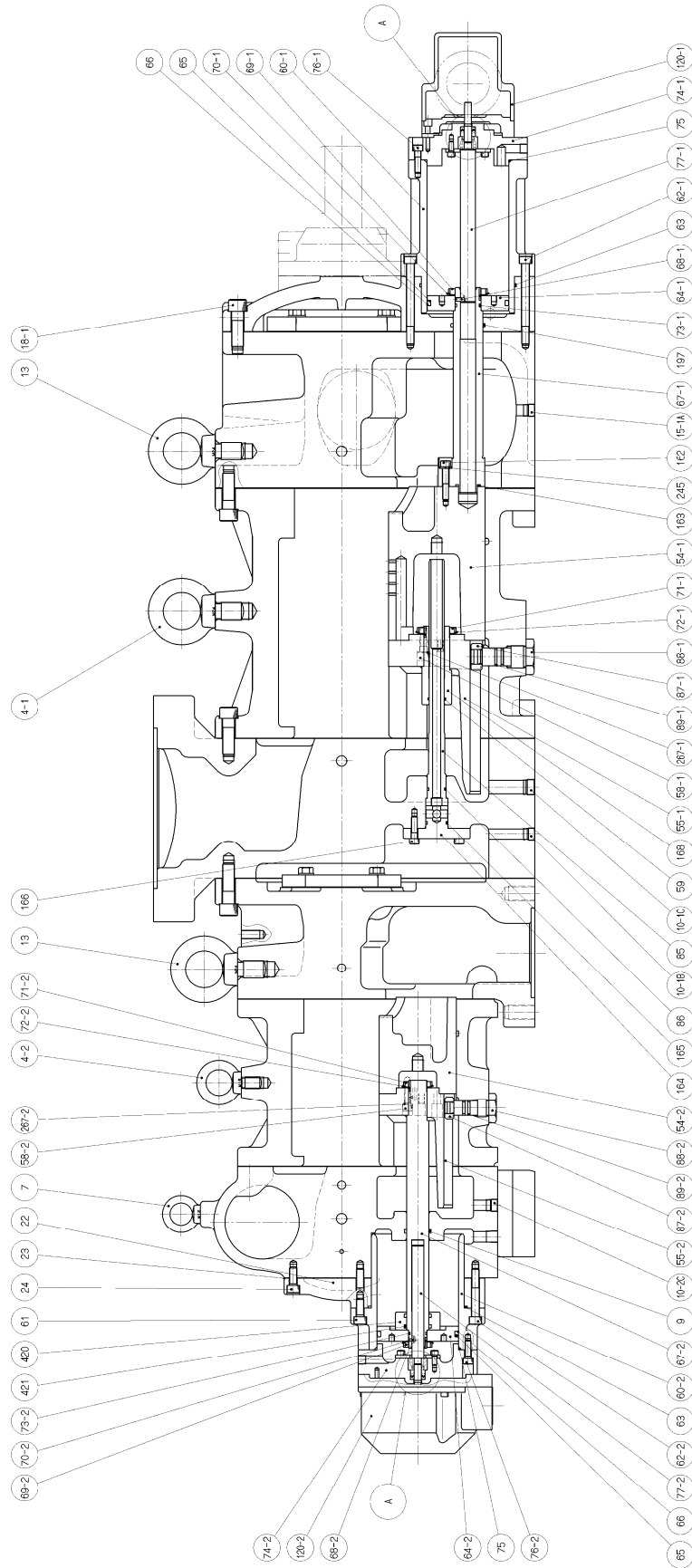

Figure 7-5 2016LMC Assembly Sectional View (Vertical)

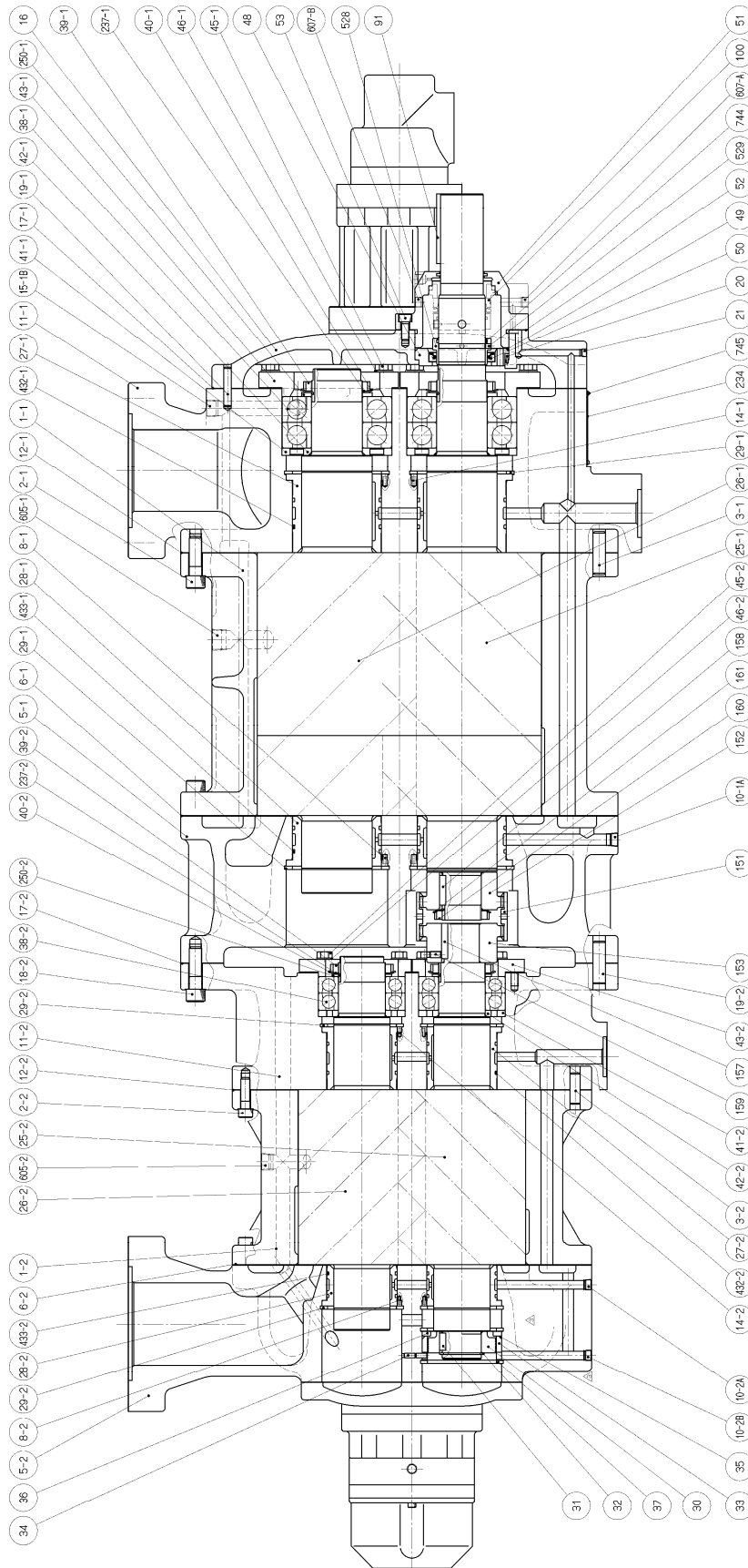

Figure 7-6 2016LMC Assembly Sectional View (Horizontal)

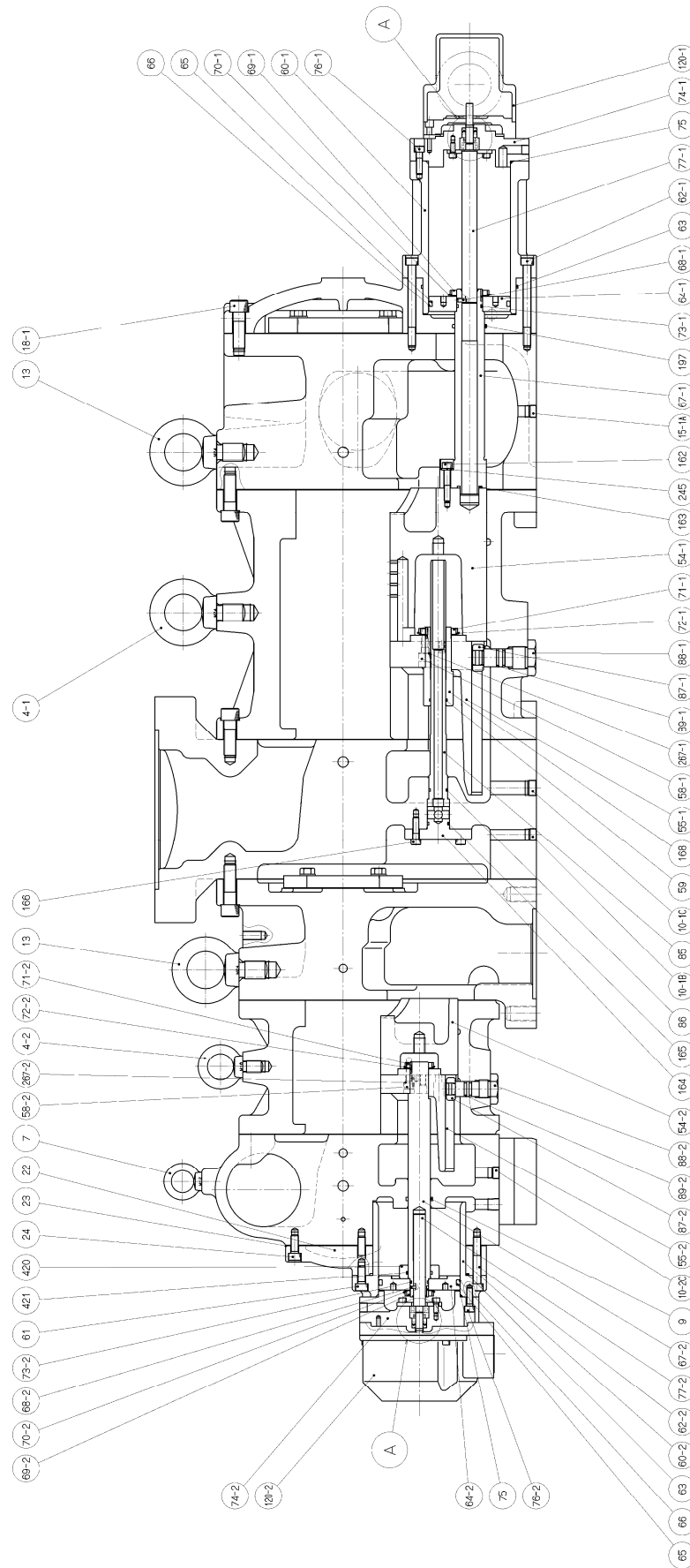

Figure 7-7 2016LSC Assembly Sectional View (Vertical)

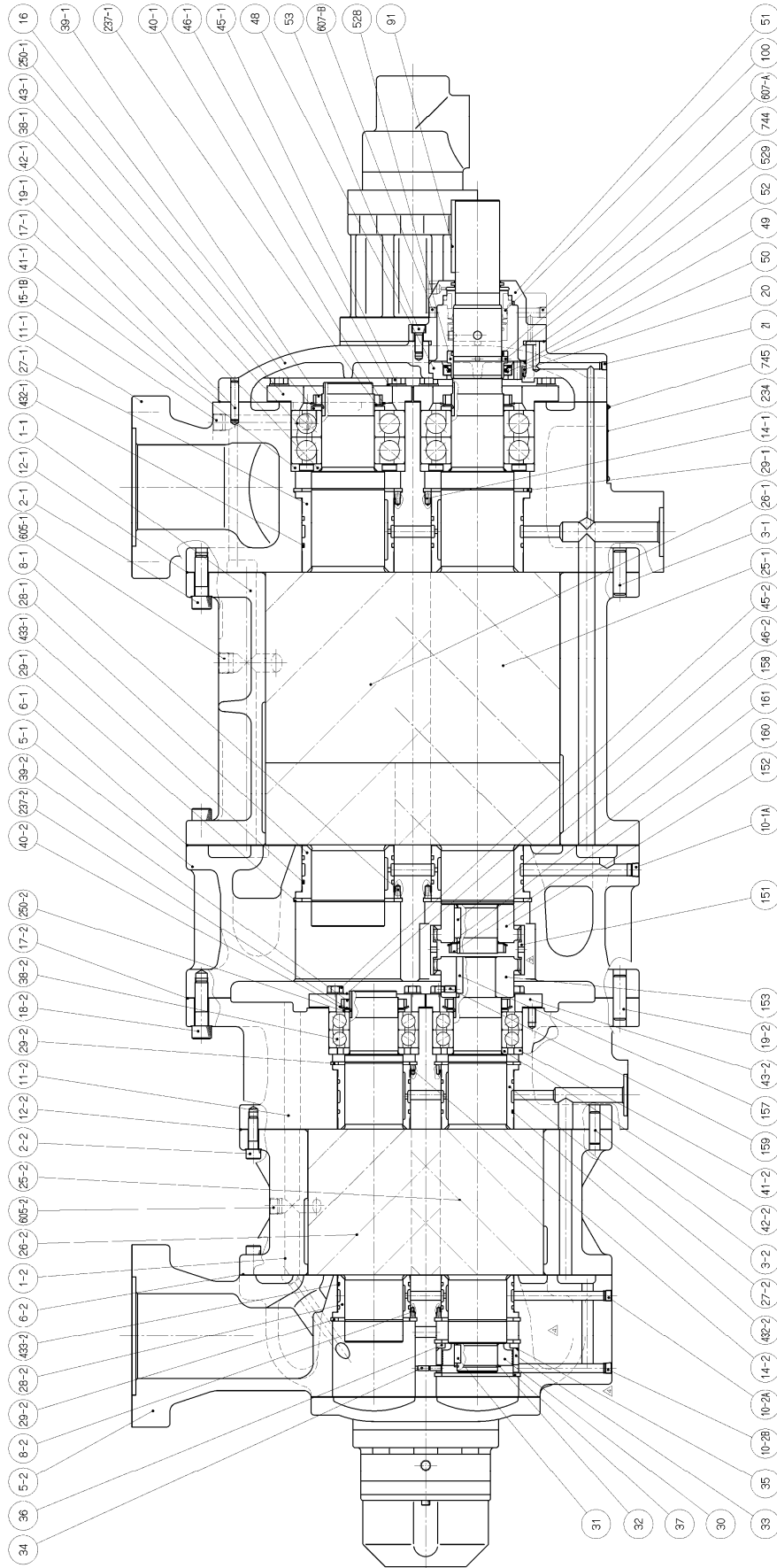

Figure 7-8 2016LSC Assembly Sectional View (Horizontal)

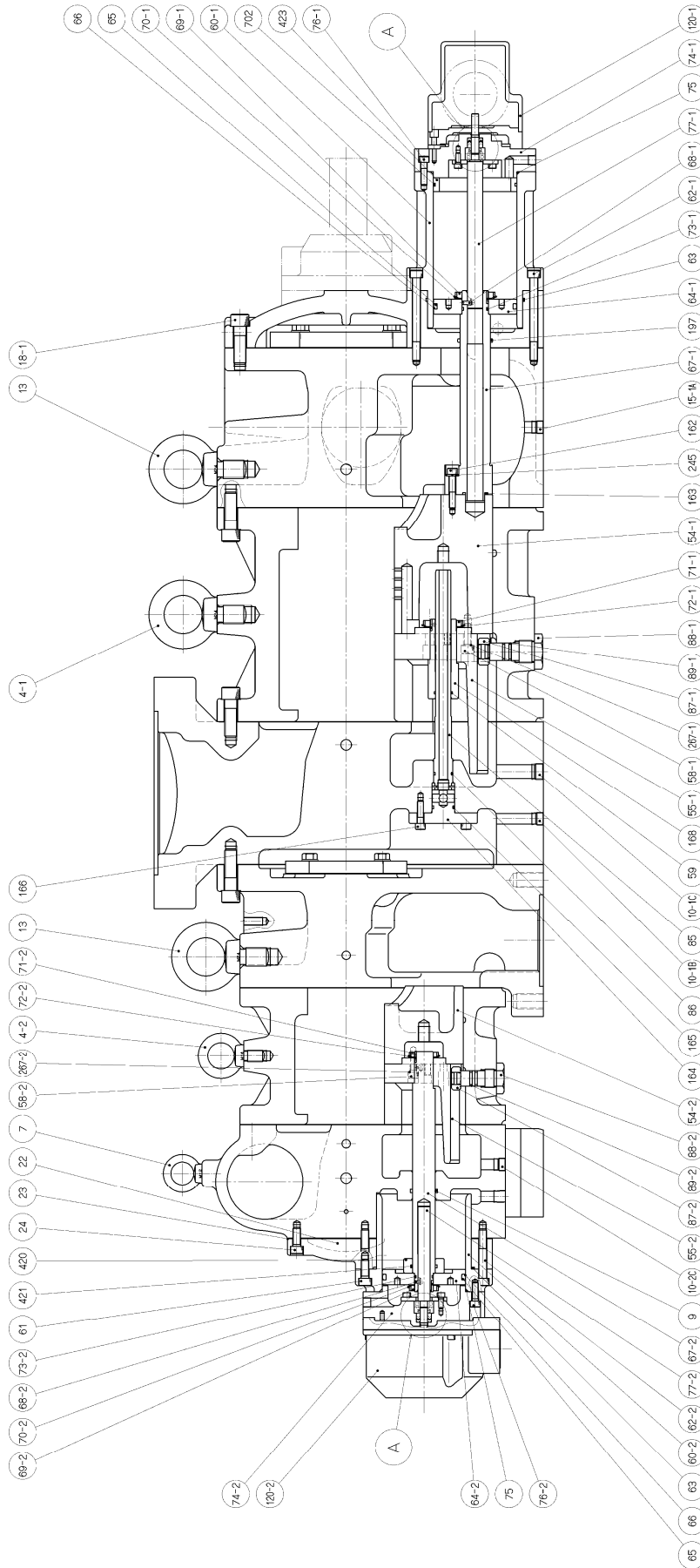

Figure 7-9 2016MSC Assembly Sectional View (Vertical)



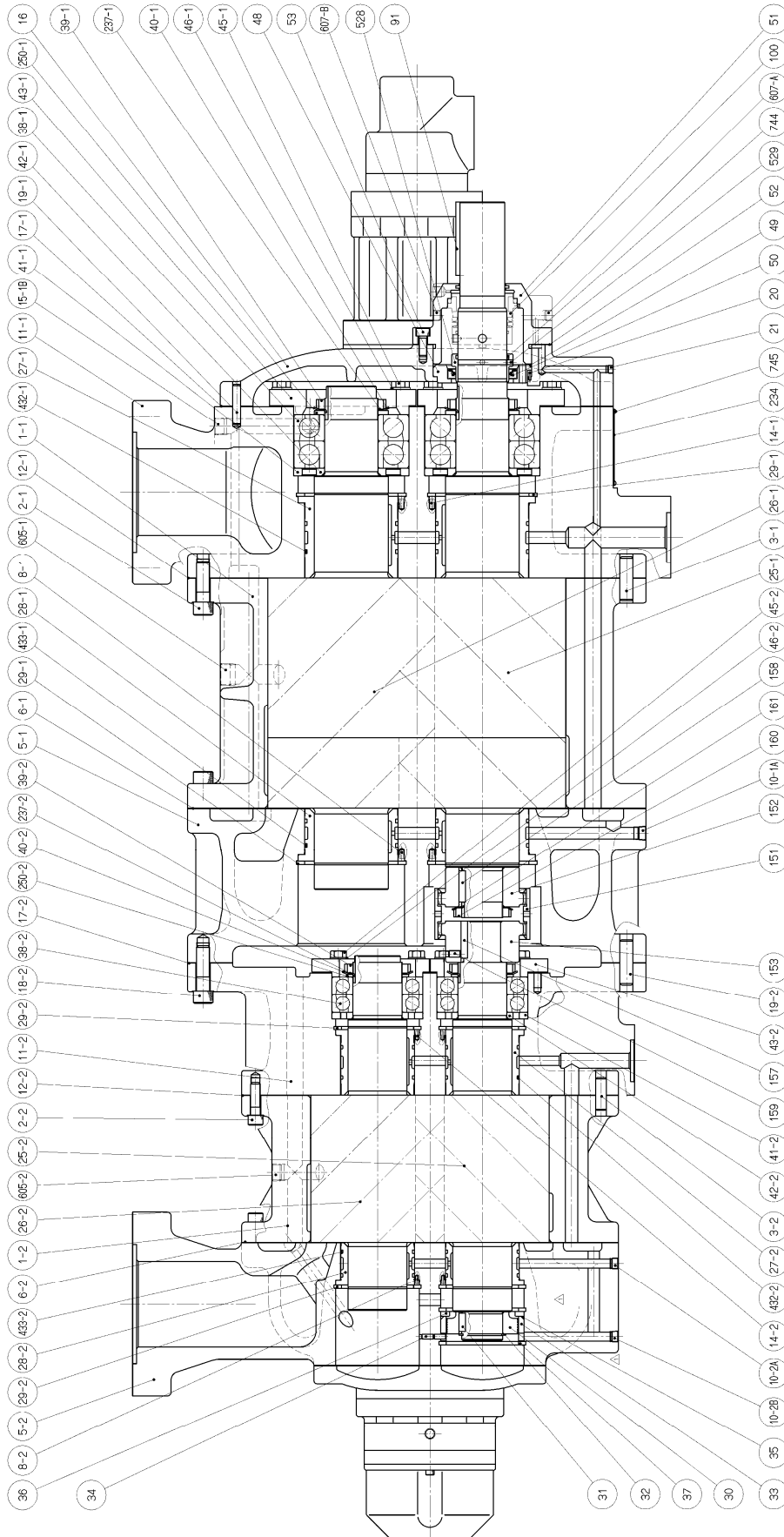

Figure 7-10 2016MSC Assembly Sectional View (Horizontal)

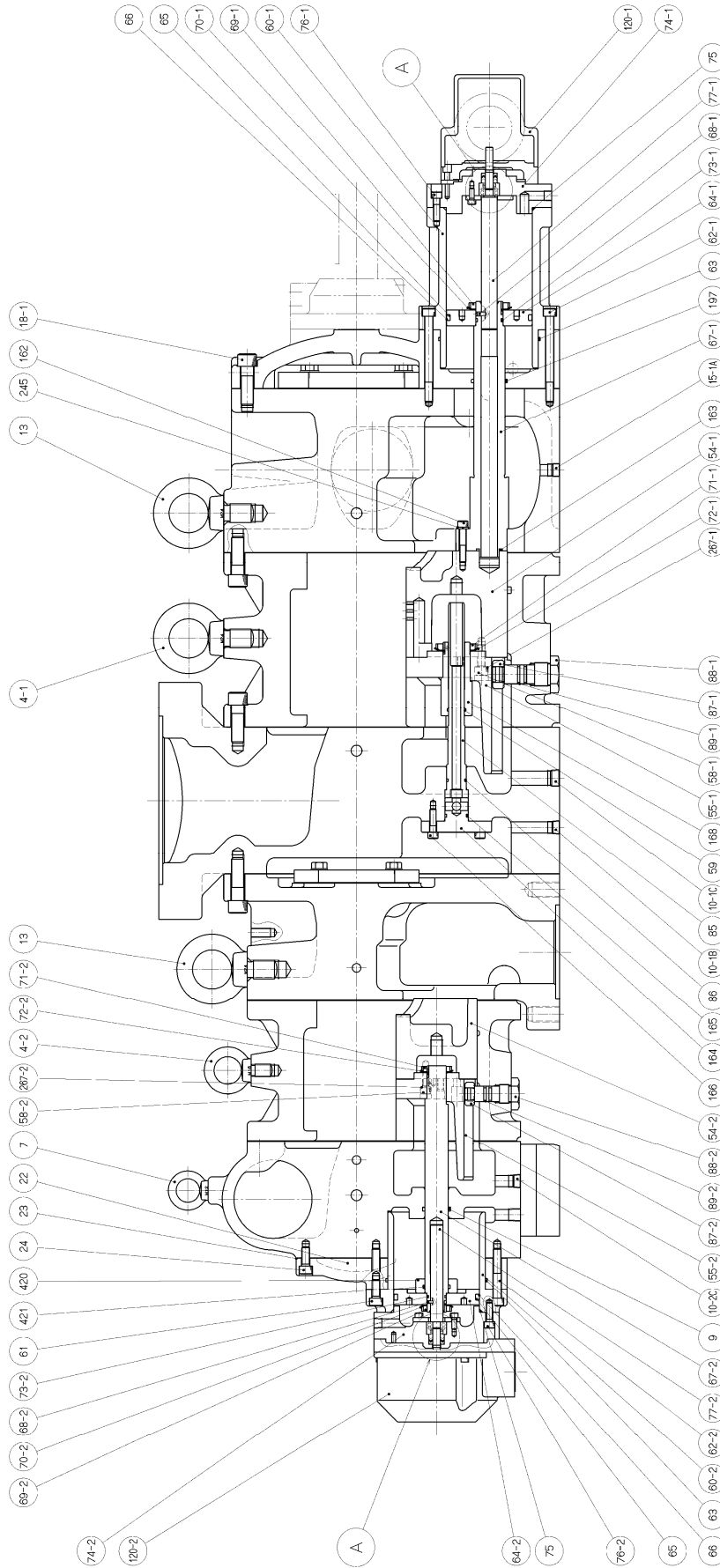

Figure 7-11 2016SSC Assembly Sectional View (Vertical)

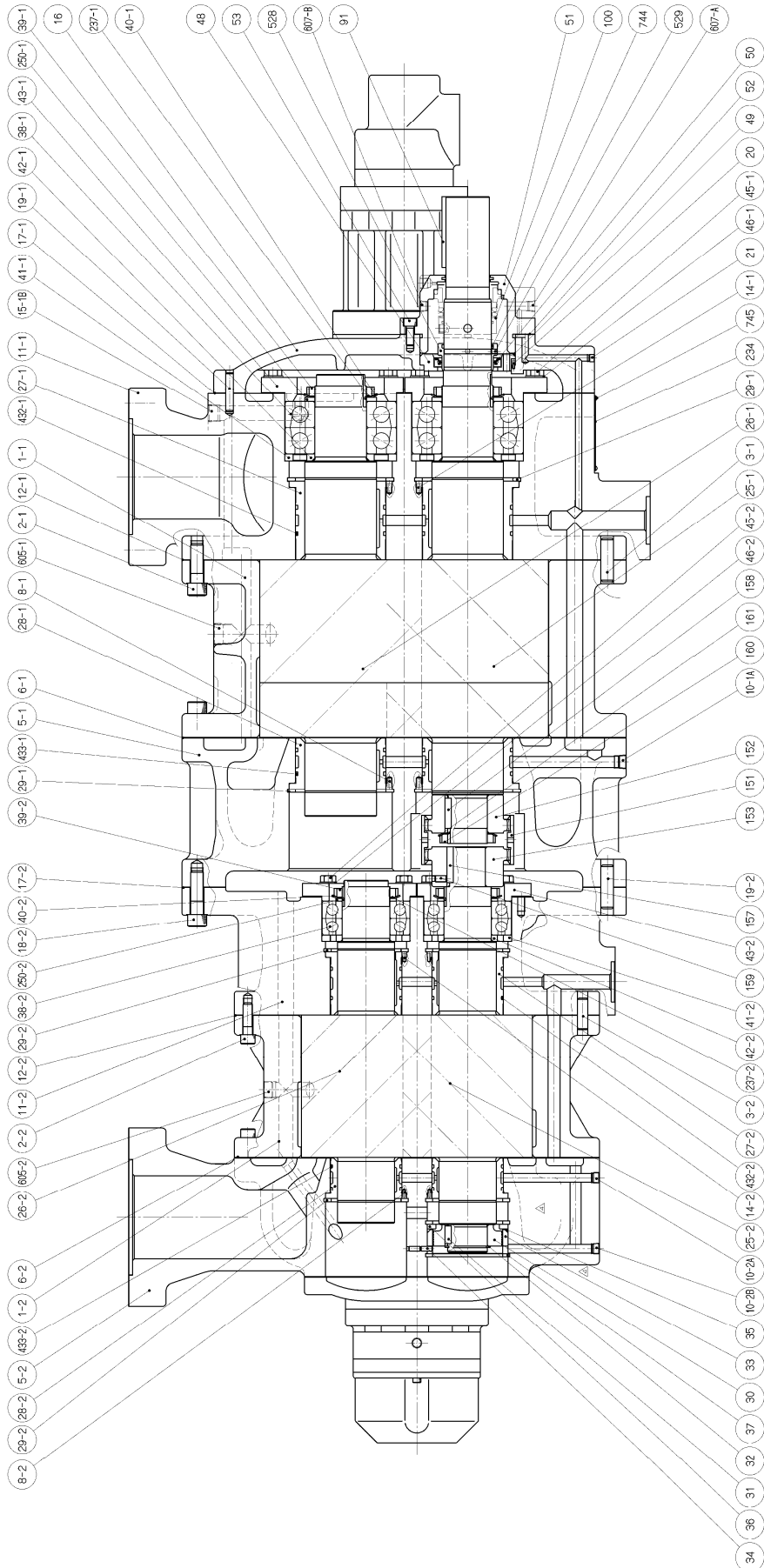

Figure 7-12 2016SSC Assembly Sectional View (Horizontal)

## 7.2 Parts Configuration Table

Table 7-1 Parts Configuration Table

P/N	Part name	Code No.	Remarks	Q'ty.					
				LLC	LMC	LSC	MMC	MSC	SSC
1-1	Main Rotor Casing (1)	CS00100-200L	200L**	1	1	1	-	-	-
1-1	Main Rotor Casing (1)	CS00100-200M	200M**	-	-	-	1	1	-
1-1	Main Rotor Casing (1)	CS00100-200S	200S**	-	-	-	-	-	1
1-2	Main Rotor Casing (2)	CS00100-160L	160L**	1	-	-	-	-	-
1-2	Main Rotor Casing (2)	CS00100-160M	160M**	-	1	-	1	-	-
1-2	Main Rotor Casing (2)	CS00100-160S	160S**	-	-	1	-	1	1
2-1	Hexagon Socket Head Cap Screw	NB35416-050	M16×50	50	50	50	50	50	50
2-2	Hexagon Socket Head Cap Screw	NB35412-040	M12×40	52	52	52	52	52	52
3-1	Alignment Pin	NE2016-055	Φ16×55	4	4	4	4	4	4
3-2	Alignment Pin	NE2013-040	Φ13×40	4	4	4	4	4	4
4-1	Eye Bolt	NB600-020	M20	1	1	1	1	1	1
4-2	Eye Bolt	NB600-016	M16	1	1	1	1	1	1
5-1	Suction Cover (1)	CS00500-2016C1	2016**C	1	1	1	1	1	1
5-2	Suction Cover (2)	CS00500-2016C2	2016**C	1	1	1	1	1	1
6-1	Gasket, Suction Cover (1)	CS00600-200N	200***	1	1	1	1	1	1
6-2	Gasket, Suction Cover (2)	CS00600-160N	160***	1	1	1	1	1	1
7	Eye Bolt	NB600-012	M12	2	2	2	2	2	2
8-1	Spring Pin (1)	NE3206-012	Φ6×12	2	2	2	2	2	2
8-2	Spring Pin (2)	NE3204-010	Φ4×10	2	2	2	2	2	2
9	O-ring	PA11-030	JIS B 2401 P30	1	1	1	1	1	1
10-1A	Plug	NF06-010	R3/8	1	1	1	1	1	1
10-1B	Plug	NF06-015	R1/2	1	1	1	1	1	1
10-2A	Plug	NF06-008	R1/4	1	1	1	1	1	1
10-2B	Plug	NF06-008	R1/4	1	1	1	1	1	1
10-2C	Plug	NF06-010	R3/8	1	1	1	1	1	1
11-1	Bearing Head (1)	CS01100-2016C1	2016**C	1	1	1	1	1	1
11-2	Bearing Head (2)	CS01100-2016C2	2016**C	1	1	1	1	1	1
12-1	Gasket, Bearing Head (1)	CS01200-200N	200***	1	1	1	1	1	1
12-2	Gasket, Bearing Head (2)	CS01200-160N	160***	1	1	1	1	1	1
13	Eye Bolt	NB600-024	M24	2	2	2	2	2	2
14-1	Spring Pin	NE320G-012	Φ6×12	2	2	2	2	2	2
14-2	Spring Pin	NE3204-010	Φ4×10	2	2	2	2	2	2
15-1A	Plug	NF06-015	R1/2	1	1	1	1	1	1
15-1B	Plug	NF06-010	R3/8	1	1	1	1	1	1
16	Bearing Cover	CS01600-2016C	2016**C	1	1	1	1	1	1
17-1	Gasket, Bearing Cover (1)	CS01700-2016C1N	2016**C	1	1	1	1	1	1
17-2	Gasket, Bearing Cover (2)	CS01700-2016C2N	2016**C	1	1	1	1	1	1
18-1	Hexagon Socket Head Cap Screw	NB35416-050	M16×50	18	18	18	18	18	18
18-2	Hexagon Socket Head Cap Screw	NB35416-055	M16×55	25	25	25	25	25	25

P/N	Part name	Code No.	Remarks	Q'ty.					
				LLC	LMC	LSC	MMC	MSC	SSC
19-1	Alignment Pin	NE2010-050	Φ10×50	2	2	2	2	2	2
19-2	Alignment Pin	NE2016-055	Φ16×55	2	2	2	2	2	2
20	Spring Pin	NE3203-010	Φ3×10	1	1	1	1	1	1
21	Plug	NF06-004	R1/8	1	1	1	1	1	1
22	Balance Piston Cover	CS02202-160VD	160***	1	1	1	1	1	1
23	Gasket, Balance Piston Cover	CS02300-160N	160***	1	1	1	1	1	1
24	Hexagon Socket Head Cap Screw	NB35410-025	M10×25	11	11	11	1	11	11
25-1	Male Rotor (1)	CS02520-2016LC1	2016L*C	1	1	1	-	-	-
26-1	Female Rotor (1)								
25-1	Male Rotor (1)	CS02520-2016MC1	2016M*C	-	-	-	1	1	-
26-1	Female Rotor (1)								
25-1	Male Rotor (1)	CS02520-2016SC1	2016S*C	-	-	-	-	-	1
26-1	Female Rotor (1)								
25-2	Male Rotor (2)	CS02520-2016LC2	2016*LC	1	-	-	-	-	-
26-2	Female Rotor (2)								
25-2	Male Rotor (2)	CS02520-2016MC2	2016*MC	-	1	-	1	-	-
26-2	Female Rotor (2)								
25-2	Male Rotor (2)	CS02520-2016SC2	2016*SC	-		1	-	1	1-
26-2	Female Rotor (2)								
27-1	Main bearing (1)	CS0270-ERT	200***	2	2	2	2	2	2
27-2	Main bearing (2)	CS0270-DRT	160***	2	2	2	2	2	2
28-1	Side bearing (1)	CS0280-ERT	200***	2	2	2	2	2	2
28-2	Side bearing (2)	CS0280-DRT	160***	2	2	2	2	2	2
29-1	Stop Ring (1)	NG11-130	H130	4	4	4	4	4	4
29-2	Stop Ring (2)	NG11-102	H102	4	4	4	4	4	4
30	Balance Piston	CS03000-160	160***	1	1	1	1	1	1
31	Key, Balance Piston	CS03100-160	160***	1	1	1	1	1	1
32	Stop Ring	NG12-050	S50	1	1	1	1	1	1
33	Sleeve, Balance Piston	CS03300-160	160***	1	1	1	1	1	1
34	Set Screw	NA83606-015	M6×15	2	2	2	2	2	2
35	O-ring	PA12-095	JIS B 2401 G95	1	1	1	1	1	1
36	Spacer, O-ring	CS03600-160	160***	1	1	1	1	1	1
37	Stop Ring	NG11-102	H102	2	2	2	2	2	2
38-1	Thrust Bearing (1)	CS03800-200P	7313B	2	2	2	2	2	2
38-2	Thrust Bearing (2)	CS03800-160P	7212B	2	2	2	2	2	2
39-1	Lock Nut (1)	NG31-013	AN13	2	2	2	2	2	2
39-2	Lock Nut (2)	NG31-012	AN12	2	2	2	2	2	2
40-1	Lock Washer (1)	NG32-013	AW13	2	2	2	2	2	2
40-2	Lock Washer (2)	NG32-012	AW12	2	2	2	2	2	2
41-1	Spacer, Thrust Bearing (1)	CS04100-200	200***	2	2	2	2	2	2
41-2	Spacer, Thrust Bearing (2)	CS04100-160	160***	2	2	2	2	2	2
42-1	Spacer, Thrust Alignment (1)	CS04200B200	200***	2	2	2	2	2	2
42-2	Spacer, Thrust Alignment (2)	CS04200-160	160***	2	2	2	2	2	2

P/N	Part name	Code No.	Remarks	Q'ty.					
				LLC	LMC	LSC	MMC	MSC	SSC
43-1	Thrust Bearing Gland (1)	CS04300-200S	200***	2	2	2	2	2	2
43-2	Thrust Bearing Gland (2)	CS043002016C2B	2016**C	2	2	2	2	2	2
45-1	Hexagon Head Bolt	NB111012-035	M12×35	8	8	8	8	8	8
45-2	Hexagon Head Bolt	NB111010-030	M10×30	8	8	8	8	8	8
46-1	Lock Washer (1)	ND150-012	200***	8	8	8	8	8	8
46-2	Lock Washer (2)	ND150-010	160***	8	8	8	8	8	8
48	Retainer, Oil Seal	CS04800-200VDS	200***	1	1	1	1	1	1
49	O-ring	PA12-115	JIS B 2401 G115	1	1	1	1	1	1
50	Oil Seal	CS05010-200VD	SA1J 65×85×12	1	1	1	1	1	1
51	Seal Cover	CS05100-200	200***	1	1	1	1	1	1
52	Gasket, Seal Cover	CS05200-200N	200***	1	1	1	1	1	1
53	Hexagon Socket Head Cap Screw	NB35410-025	M10×25	8	8	8	8	8	8
54-1	Unloader Slide Valve (1-1) (L port)	CS05400-2016****	2016LSC	1	1	1	-	-	-
54-1	Unloader Slide Valve (1-1) (M port)		2016LSC	1	1	1	-	-	-
54-1	Unloader Slide Valve (1-1) (L port)		2016MSC	-	-	-	1	1	-
54-1	Unloader Slide Valve (1-1) (M port)		2016MSC	-	-	-	1	1	-
54-1	Unloader Slide Valve (1-1) (L port)		2016SSC	-	-	-	-	-	1
54-1	Unloader Slide Valve (1-1) (M port)		2016SSC	-	-	-	-	-	1
54-2	Unloader Slide Valve (1-2) (L port)		2016*SC	-	-	1	-	1	1
54-2	Unloader Slide Valve (1-2) (M port)		2016*SC	-	-	1	-	1	1
54-2	Unloader Slide Valve (1-2) (H port)		2016MSC	-	-	-	-	1	-
54-2	Unloader Slide Valve (1-2) (L port)		2016LLC	1	-	-	-	-	-
54-2	Unloader Slide Valve (1-2) (M port)		2016*LC	1	-	-	-	-	-
54-2	Unloader Slide Valve (1-2) (L port)		2016LMC	-	1	-	1	-	-
54-2	Unloader Slide Valve (1-2) (M port)		2016*MC	-	1	-	1	-	-
55-1	Unloader Slide Valve (2-1)		200L**	1	1	1	-	-	-
55-1	Unloader Slide Valve (2-1)		200M**	-	-	-	1	1	-
55-1	Unloader Slide Valve (2-1)		200S**	-	-	-	-	-	1
55-2	Unloader Slide Valve (2-2)		160L**	1	-	-	-	-	-
55-2	Unloader Slide Valve (2-2)		160M**	-	1	-	1	-	-
55-2	Unloader Slide Valve (2-2)		160S**	-	-	1	-	1	1
58-1	Hexagon Socket Head Cap Screw	NB35410-030	M10×30	4	4	4	4	4	4
58-2	Hexagon Socket Head Cap Screw	NB35408-025	M8×25	4	4	4	4	4	4
59	O-ring	PA11-020	JIS B 2401 P20	1	1	1	1	1	1
60-1	Unloader Cylinder	CS06000-2016C	2016LSC	1	1	1	1	1	1

P/N	Part name	Code No.	Remarks	Q'ty.					
				LLC	LMC	LSC	MMC	MSC	SSC
60-2	Unloader Cylinder	CS06000-160L	160L**	1	-	-	-	-	-
60-2	Unloader Cylinder	CS06000-160M	160M**	-	1	-	1	-	-
60-2	Unloader Cylinder	CS06000-160S	160S**	-	-	1	-	1	1
61	Hexagon Socket Head Cap Screw	NB35410-025	M10×25	2	2	2	2	2	2
62-1	Hexagon Socket Head Cap Screw	NB35410-110	M10×110	8	8	8	8	8	8
62-2	Hexagon Socket Head Cap Screw	NB35410-065	M10×65	6	6	6	6	6	6
63	O-ring	PA12-125	JIS B 2401 G125	2	2	2	2	2	2
64-1	Unloader Piston (1)	CS06400-2016T	2016LSC	1	1	1	1	1	1
64-2	Unloader Piston (2)	CS06400-160T	160***	1	1	1	1	1	1
65	O-ring	PA11-100	JIS B 2401 P100	2	2	2	2	2	2
66	Cap Seal	CS06600-160	BE100	2	2	2	2	2	2
67-1	Push Rod, Unloader Slide Valve (1)	CS06700-2016C1	2016LSC	1	1	1	1	1	-
67-1	Push Rod, Unloader Slide Valve (1)	CS06700-2016SSC	2016SSC	-	-	-	-	-	1
67-2	Push Rod, Unloader Slide Valve (2)	CS06700-2016C2	2016LSC	-	-	1	-	1	1
67-2	Push Rod, Unloader Slide Valve (2)	CS06700-2016LLC	2016LLC	1	-	-	-	-	-
67-2	Push Rod, Unloader Slide Valve (2)	CS06700-2016LMC	2016LMC	-	1	-	1	-	-
68-1	Guide Pin	NE2505-012	Φ5×12	1	1	1	1	1	1
68-2	Guide Pin	NE2503-008	Φ3×8	1	1	1	1	1	1
69-1	Lock Nut (1)	NG31-007	AN07	1	1	1	1	1	1
69-2	Lock Nut (2)	NG31-005	AN05	1	1	1	1	1	1
70-1	Lock Washer (1)	NG32-007	AW07	1	1	1	1	1	1
70-2	Lock Washer (2)	NG32-005	AW05	1	1	1	1	1	1
71-1	Lock Nut (1)	NG31-007	AN07	1	1	1	1	1	1
71-2	Lock Nut (2)	NG31-005	AN05	1	1	1	1	1	1
72-1	Lock Washer (1)	NG32-007	AW07	1	1	1	1	1	1
72-2	Lock Washer (2)	NG32-005	AW05	1	1	1	1	1	1
73-1	O-ring	PA12-030	JIS B 2401 G30	1	1	1	1	1	1
73-2	O-ring	PA11-021	JIS B 2401 P21	1	1	1	1	1	1
74-1	Unloader Cover (1)	CS07400-2016S	2016LSC	1	1	1	-	-	1
74-1	Unloader Cover (1)	CS07400-2016MSC	2016MSC	-	-	-	1	1	-
74-2	Unloader Cover (2)	CS07400-160S	160***	1	1	1	1	1	1
75	O-ring	PA12-110	JIS B 2401 G110	2	2	2	2	2	2
76-1	Hexagon Socket Head Cap Screw	NB35408-030	M8×30	8	8	8	8	8	8
76-2	Hexagon Socket Head Cap Screw	NB35408-025	M8×25	8	8	8	8	8	8
77-1	Indicator Cam (1)	CS07700-2016C	2016LSC	1	1	1	-	-	-
77-1	Indicator Cam (1)	CS07700-2016MSC	2016MSC	-	-	-	1	1	-
77-1	Indicator Cam (1)	CS07700-2016SSC	2016SSC	-	-	-	-	-	1
77-2	Indicator Cam (2)	CS07700-160L	160L**	1	-	-	-	-	-
77-2	Indicator Cam (2)	CS07700-160M	160M**	-	1	-	1	-	-
77-2	Indicator Cam (2)	CS07700-160S	160S**	-	-	1	-	1	1
78	Ball Bearing	CS07800-200	#6000	2	2	2	2	2	2

P/N	Part name	Code No.	Remarks	Q'ty.					
				LLC	LMC	LSC	MMC	MSC	SSC
79	Stop Ring	NG12-010	S10	2	2	2	2	2	2
80	Bearing Gland	CS08000-200	200***	2	2	2	2	2	2
81	Hexagon Socket Head Cap Screw	NB35406-015	M6×15	6	6	6	6	6	6
82	V-ring	CS08200-200B	20×10×12	2	2	2	2	2	2
83	Spring	CS08300-200	200***	2	2	2	2	2	2
84	Retainer, Indicator Cam Spring	CS08400-200	200***	2	2	2	2	2	2
85	Oil Injection Pipe	CS08500-200LUK	200LU*	1	1	1	-	-	-
85	Oil Injection Pipe	CS08500-2016MSC	2016MSC	-	-	-	1	1	-
85	Oil Injection Pipe	CS08500-2016SSK	2016SSC	-	-	-	-	-	1
86	O-ring	PA11-021	JIS B 2401 P21	1	1	1	1	1	1
87-1	Guide Block (1)	CS08700-200	200***	1	1	1	1	1	1
87-2	Guide Block (2)	CS08700-160	160***	1	1	1	1	1	1
88-1	Stem, Guide Block (1)		200&250***	1	1	1	1	1	1
88-2	Stem, Guide Block (2)		160***	1	1	1	1	1	1
89-1	O-ring	PA11-020	JIS B 2401 P20	2	2	2	2	2	2
89-2	O-ring	PA11-016	JIS B 2401 P16	2	2	2	2	2	2
91	Shaft key (1)	CS09100-200	200***	1	1	1	1	1	1
92-1	Suction Flange (1)	CS71300-150	JIS 20K 150A(6")	1	1	1	1	1	1
92-2	Suction Flange (2)	CS71300-100	JIS 20K 100A(4")	1	1	1	1	1	1
93-1	Gasket, Suction Flange (1)	CS71200-150N	JIS 20K 150A(6")	1	1	1	1	1	1
93-2	Gasket, Suction Flange (2)	CS71200-100N	JIS 20K 100A(4")	1	1	1	1	1	1
94-1	Hexagon Head Bolt	NB12022-055	M22×55	12	12	12	12	12	12
94-2	Hexagon Head Bolt	NB12020-055	M20×55	8	8	8	8	8	8
95-1	Discharge Flange (1)	CS71300-100	JIS 20K 100A(4")	1	1	1	1	1	1
95-2	Discharge Flange (2)	CS71300-080	JIS 20K 80A(3")	1	1	1	1	1	1
96-1	Gasket, Discharge Flange (1)	CS71200-100N	JIS 20K 100A(4")	1	1	1	1	1	1
96-2	Gasket, Discharge Flange (2)	CS71200-080N	JIS 20K 80A(3")	1	1	1	1	1	1
97-1	Hexagon Head Bolt	NB12020-055	M20×55	8	8	8	8	8	8
97-2	Hexagon Head Bolt	NB12020-055	M20×55	8	8	8	8	8	8
100	Mechanical Seal Assembly (BBSE)	CS10002-200EBS	BBS-E	1	1	1	1	1	1
120-1	Unloader Indicator Assembly (1)	CS12000-1612F	1612LSC	1	1	1	1	1	1
120-2	Unloader Indicator Assembly (2)	CS12000-200F	200*** 20-100 %	1	1	1	1	1	1
151	Driven Sleeve	CS15100-2016		1	1	1	1	1	1
152	Drive Hub			1	1	1	1	1	1
153	Driven Hub			1	1	1	1	1	1
154	Stopper, Driven Sleeve	CS15400-2016C		2	2	2	2	2	2
155	Stop Ring		FRS-90	4	4	4	4	4	4
157	Key, Driven Hub	CS15700-2016C		1	1	1	1	1	1
158	Key, Drive Hub	CS15800-2016C		1	1	1	1	1	1
159	Set Screw	NA83608-015	M8×15 knurled with anti-loosening	1	1	1	1	1	1
160	Lock Nut	NG31-010	AN10	1	1	1	1	1	1
161	Lock Washer	NG32-010	AW10	1	1	1	1	1	1



P/N	Part name	Code No.	Remarks	Q'ty.					
				LLC	LMC	LSC	MMC	MSC	SSC
162	Hexagon Socket Head Cap Screw	NB35406-045	M8×45	5	5	5	5	5	5
163	O-ring	PA12-025	JIS B 2401 G25	1	1	1	1	1	1
164	Retainer, Oil Injection Pipe	CS16400-2016C		1	1	1	1	1	1
165	O-ring	PA12-025	JIS B 2401 G25	1	1	1	1	1	1
166	Hexagon Socket Head Cap Screw	NB35408-030	M8×30	4	4	4	4	4	4
168	Pipe Guide, Oil Injection	CS16800-2016		1	1	1	1	1	1
197	O-ring	PA11-040	JIS B 2401 P40	1	1	1	1	1	1
215-1	Flange, Lubrication Oil Supply (1)	CS71300-025	JIS 20K 25A(1")	1	1	1	1	1	1
215-2	Flange, Lubrication Oil Supply (2)	CS71300-020	JIS 20K 20A(3/4")	1	1	1	1	1	1
216-1	Gasket, Lubrication Oil Supply Flange (1)	CS71200-025N	JIS 20K 25A	1	1	1	1	1	1
216-2	Gasket, Lubrication Oil Supply Flange (2)	CS71200-020N	JIS 20K 20A	1	1	1	1	1	1
217-1	Hexagon Head Bolt	NB111016-045	M16×45	4	4	4	4	4	4
217-2	Hexagon Head Bolt	NB111012-035	M12×35	4	4	4	4	4	4
218	Flange, Injection Oil Supply	CS71300-015	JIS 20K 15A(1/2")	1	1	1	1	1	1
219	Gasket, Injection Oil Supply Flange	CS71200-015N	JIS 20K 15A	1	1	1	1	1	1
220	Hexagon Head Bolt	NB111012-035	M12×35	4	4	4	4	4	4
237-1	Torsional Slip Washer (1)	CS23700-200	200***	2	2	2	2	2	2
237-2	Torsional Slip Washer (2)	CS23700-160	160***	2	2	2	2	2	2
245	Special Spring Washer for Hexagon Socket Head Cap Screw	ND330-08	M8	5	5	5	5	5	5
250-1	Thrust Washer (1)	CS25000-200	200***	2	2	2	2	2	2
250-2	Thrust Washer (2)	CS25000-160	160***	2	2	2	2	2	2
267-1	Special Spring Washer for Hexagon Socket Head Cap Screw	ND330-10	M10	4	4	4	4	4	4
267-2	Special Spring Washer for Hexagon Socket Head Cap Screw	ND330-08	M8	4	4	4	4	4	4
420	Unload Spacer	CS42000-160L20	For 2016*LC(2) 20 % load	1	-	-	-	-	-
420	Unload Spacer	CS42000-160M20	For 2016*MC(2) 20 % load	-	1	-	1	-	-
420	Unload Spacer	CS42000-160S20	For 2016*SC(2) 20 % load	-	-	1	-	1	1
421	O-ring	PA12-030	JIS B 2401 G30	-	-	1	-	1	1
421	O-ring	PA11-030	JIS B 2401 P30	2	2	-	1	-	-
423	Unload spacer		Used for MSC low-stage only.	-	-	-	1	1	-
424	Hexagon Socket Head Cap Screw	NB35406-020	M6×20 Note 1	-	-	-	3	3	-
432-1	O-ring	PA62-022	AS568A-244 (JIS W1516 G22)	4	4	4	4	4	4
432-2	O-ring	PA12085	JISB2401 1A G85	4	4	4	4	4	4
433-1	O-ring	PA62022	AS568A-244 (JIS W1516 G22)	4	4	4	4	4	4

P/N	Part name	Code No.	Remarks	Q'ty.					
				LLC	LMC	LSC	MMC	MSC	SSC
433-2	O-ring	PA12-085	JIS B 2401 G85	4	4	4	4	4	4
528	Sleeve, Oil Seal	CS52809-200VD	200V** with O-ring	1	1	1	1	1	1
529	Set Screw	NA83606-008	M6×8	2	2	2	2	2	2
605-1	Plug	NF06-008	R3/4	1	1	1	1	1	1
605-2	Plug	NF06-015	R1/2	1	1	1	1	1	1
607	Plug	NF06-004	R1/8	1	1	1	1	1	1
702	O-ring	PA12-100	JIS B 2401 G100 <b>Note 1</b>	-	-	-	1	1	-
744	O-ring	PA12-060	JISB2401 1A G60	1	1	1	1	1	1
-	O-ring Set	CS7109-0K	2016C NBR						
-	O-ring Set	CS7109-5K	2016C FPM						
-	Gasket Set	CS7118-0K	2016C						
-	Lock Nut and Washer Set	CS8009-K	2016C						

### CAUTION

- The part code of the O-ring except for "O-ring set 2016C FKM" is the one assigned to NBR which is standard material. When the material of the O-ring is other than NBR, a different part code is used for each material.  
If you are using O-rings made from other than the standard material, please contact MAYEKAWA when placing an order.

**Note 1:** The hexagon socket head cap screw (No. 424) is used to fasten the unload spacer (No. 423), which is for the exclusive use of the MSC low-stage, to the unloader cover (No. 74-1). In April 2007, this spacer and the explosion proof type unloader piston spacer were standardized according to the design change. As a result, the use of this part is discontinued. One piece of O-ring (No.702) (JIS B 2401 G100) is used instead of this part. According to this design change, the use of the MSC unloader cover (1) with bolt hole for spacer is also discontinued. The MSC unloader cover and the LSC unloader cover are shared/standardized.

## 7.3 Tightening Torques for Bolts and Nuts

Table 7-2 List of Tightening Torques

### ■ Hexagon socket head cap screw

P/N	What is tightened	Tightening torque		Q'ty.	Size
		N·m	kgf·cm		
2-1	Main Rotor Casing (1) to Suction Cover (1) and Bearing Head (1)	240	2400	50	M16×50
2-2	Main Rotor Casing (2) to Suction Cover (2) and Bearing Head (2)	90	900	52	M12×40
18-1	Bearing Cover to Bearing Head (1)	240	2400	18	M16×50
18-2	Bearing Head (2) to Suction Cover (1)	240	2400	25	M16×55
24	Balance Piston Cover to Suction Cover (2)	50	500	11	M10×25
53	Seal Cover to Bearing Cover	50	500	8	M10×25
58-1	For Securing Unloader Slide Valve	50	500	4	M10×30
58-2	For Securing Unloader Slide Valve	25	250	4	M8×25
61	Unloader Cylinder (2) to Balance Piston Cover	50	500	2	M10×25
62-1	Unloader Cylinder (1) to Bearing Cover and Bearing Head (1)	50	500	8	M10×110
62-2	Unloader Cylinder (2) to Balance Piston Cover and Suction Cover	50	500	6	M10×65
76-1	Unloader Cylinder Cover (1) to Unloader Cylinder (1)	25	250	8	M8×30
76-2	Unloader Cylinder Cover (2) to Unloader Cylinder (2)	25	250	8	M8×25
81	Bearing Gland	10	100	6	M6×15
162	Push Rod, Unloader Slide Valve (1)	25	250	5	M8×45
166	Retainer, Oil Injection Pipe	25	250	4	M8×30

### ■ Hexagon Head Bolt

P/N	What is tightened	Tightening torque		Q'ty.	Size
		N·m	kgf·cm		
45-1	Thrust Bearing Gland (1)	50	500	8	M12×35
45-2	Thrust Bearing Gland (2)	40	400	8	M10×30
94-1	Suction Flange (1) JIS20K 150A	240	2400	12	M22×55
94-2	Suction Flange (intermediate pipe) (2) JIS20K 100A	180	1800	8	M20×55
97-1	Discharge Flange (intermediate pipe) (1) JIS20K 100A	180	1800	8	M20×55
97-2	Discharge Flange (2) JIS20K 80A	120	1200	8	M16×55

■ Lock Nut

P/N	What is tightened	Tightening torque (N·m)		Q'ty.	Size
		Standard	Maximum		
39-1	Thrust Bearing (1) Note 1	522	653	2	AN13
39-2	Thrust Bearing (2) Note 1	408	510	2	AN12
69-1	Unloader Piston (1)	120	-	1	AN07
69-2	Unloader Piston (2)	80	-	1	AN05
71-1	Unloader Slide Valve (1-1)	79	99	1	AN07
71-2	Unloader Slide Valve (1-2)	28	35	1	AN05
160	Gear Coupling Drive Hub Note 1	238	297	1	AN10

Note 1: When tightening a lock nut, if it is difficult to use a torque wrench, manage the tightening torque of the lock nut controlling the tightening angle range as explained below.

■ Tightening Angle Range of Lock Nuts for Rotors

- After tightening the lock nut by hand, further tighten the lock nut by using a lock nut wrench until the rotor starts to turn. Take care not to over-tighten.
- Put a mark on the lock nut at the right side edge of the rotor groove where the stopper tongue of the lock washer fits in, as shown in Figure 7-9.
- From this marking position, tighten the lock nut in such a way that rotation can be stopped within the tightening angle range shown in Table 7-3 (2016\*\*C 【39-1】 , 【39-2】 and 【160】 : 30° to 40°(first time tightening), 20° to 30°(second time tightening). When measuring the angle, use an angle gauge which is set to the diameter of rotor shaft.

Table 7-3 Tightening Angles Specified for Lock Nuts of Rotor

Model		Angle range
2016**C Low-stage High-stage	First time tightening	30° to 40°
	Second time tightening	20° to 30°

Rotor groove (slot) where stopper tongue of the lock washer fits

Marking

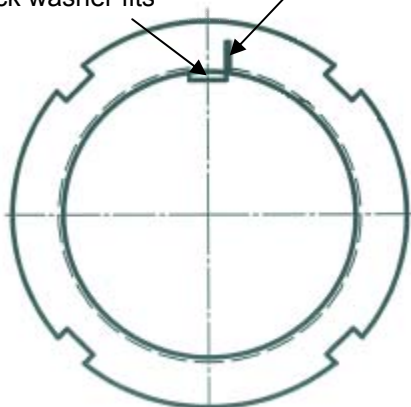

Figure 7-9 Position where mark is put

\* When tightening lock nut, tightening start position differs between the first time tightening and the tightening for the second time or after. Therefore, angle ranges are specified also for the second time tightening.

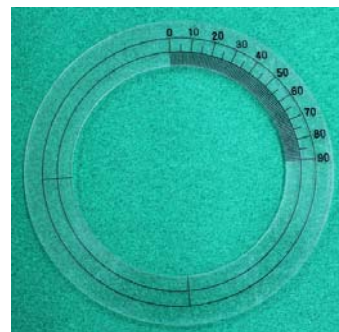

Photo 122 Angle Gauge (example)

## 7.4 About the O-rings Used

### 7.4.1 List of O-rings Used

Table 7-4 List of O-rings Used

P/N	Location		nominal symbols
	attached place	description in functional aspect	
9	Suction Cover (2)	Push Rod	P30
35	Sleeve, Balance Piston	same as left	G95
49	Oil Seal Retainer	same as left	G115
59	Pipe Guide, Oil Injection	Oil Injection Pipe	P20
63	Bearing Cover, Balance Piston Cover	Unloader Cylinder (1), (2)	G125
65	Unloader Piston (1), (2)	same as left	P100
73-1	Unloader Push Rod (1)	Unloader Piston (1)	G30
73-2	Unloader Push Rod (2)	Unloader Piston (2)	P21
75	Unloader Cylinder Cover (1), (2)	same as left	G110
86	Oil Injection Pipe	same as left	P21
89-1	Stem, Guide block (1)	same as left	P20
89-2	Stem, Guide block (2)	same as left	P16
163	Unloader Slide Valve (1)	same as left	G25
165	Gland, Oil Injection Pipe	same as left	G25
197	Bearing Cover	Push Rod, Unloader Slide Valve (1)	P40
421	Unload Spacer 2016*SC (2)	same as left	G30
421	Unload Spacer 2016*LC (2), *MC (2)	same as left	P30
432-1	Main Bearing (1)	same as left	AS568A-244
432-2	Main Bearing (2)	same as left	G85
433-1	Side Bearing (1)	same as left	AS568A-244
433-2	Side Bearing (2)	same as left	G85
702	Unloader Spacer (used for MSC low-stage only)	same as left	G100
744	Sleeve, Oil Seal	same as left	G60

■ Designation codes are based on JIS B 2401 except AS568A-244.

■ Attached place means parts which they have grooves or with taper cutting for attaching O-ring.









### 7.4.2 O-ring Materials Used for Screw Compressor

Table 7-5 List of O-ring Materials Used for Screw Compressor  
(excluding mechanical seal)

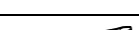
Working fluid	O-ring material
Ammonia	NBR
Hydrofluorocarbon (HFC)	
CO <sub>2</sub>	FKM
	HNBR
Trifluoromethane (R23)	FKM
Propane	
Propylene	
Natural gas	
City gas	
Helium	

## 7.5 Tools for Disassembly

Table 7-6 List of Tools for Disassembly

Tool name	Illustration	size, etc.;	Parts Center Code No.
Ratchet wrench		1/4"	SG261-08
Adjustable wrench		250mm	SG231-250
Screwdriver		Philips	SG112-075
Screwdriver		Flat blade	SG111-075
Stop ring pliers		External (for shaft)	SG311-03
Stop ring pliers		Internal (for groove)	SG312-04
Eye bolt		M8 two-piece-set	UHT0016
Allen wrench key		Across flats 2mm	SG241-02
		3mm	SG241-03
		4mm	SG241-04
		5mm	SG241-05
		6mm	SG241-06
		8mm	SG241-08
		10mm	SG241-10
		12mm	SG241-12
Lock nut wrench		AN-05	SAS111-05
		AN-07	SAS111-07
		AN-10(L)	SAS112-10
		AN-12	SAS111-12
		AN-13	SAS111-13
Torque wrench for assembly		5-25N·m	-
		20-100N·m	SG132-0900
		40-280N·m	SG132-2800

## Contact Information

### Sales Offices/Service Centers

#### ■ Sales Offices in Japan (as of April 21, 2015)

Description	Location	Phone/Fax
Head Office	3-14-15 BOTAN KOTO-KU, TOKYO 135-8482	TEL: 03-3642-8181 FAX: 03-3643-7094
Hokkaido Branch	2-5-1, 3-JYO NIJYUUYONKEN NISHI-KU, SAPPORO-CITY, HOKKAIDO 063-0803	TEL: 011-631-2052 FAX: 011-631-2053
Tohoku Branch	8-72, ROKUTYONO-MEMINAMI-MACHI, WAKABAYASHI-KU, SENDAI-CITY, MIYAGI 984-0013	TEL: 022-288-5001 FAX: 022-288-5155
Kanto Branch	3-14-15 BOTAN, KOTO-KU, TOKYO 135-8482	TEL: 03-3642-8968 FAX: 03-3641-8468
Chubu Branch	2-9-6, MARUNOUCHI, NAKA-KU, NAGOYA CITY, AICHI 460-0002	TEL: 052-218-3307 FAX: 052-218-3308
Kansai Branch	1-4-27, EBIE, FUKUSHIMA-KU, OSAKA CITY, OSAKA 553-0001	TEL: 06-4795-6000 FAX: 06-4795-6033
Chugoku Branch	2-3-40, TAKAYADAI, HIGASHIHIROSHIMA CITY, HIROSHIMA 739-2117	TEL: 082-491-1830 FAX: 082-491-1838
Shikoku Branch	410-1, OTAKAMI-MACHI, TAKAMATSU-CITY, KAGAWA 761-2117	TEL: 087-868-3400 FAX: 087-868-3399
Kyushu Branch	FUKUOKA-FUJILAND-BUILD. 10F, 2-3, NAKASHIMA-MACHI, NAKASU, HAKATA-KU, FUKUOKA CITY, FUKUOKA 810-0802	TEL: 092-262-0016 FAX: 092-262-0115

#### ■ Manufacturing Bases in Japan (as of April 21, 2015)

Description	Location	Phone/Fax
Moriya Plant	2000, TATSUZAWA MORIYA-CITY, IBARAKI 302-0118	TEL: 0297-48-1361 FAX: 0297-48-5269
Higashi-Hiroshima Plant	2-3-40, TAKAYADAI, HIGASHIHIROSHIMA CITY, HIROSHIMA 739-2117	TEL: 082-491-1828 FAX: 082-491-1838

■ **Global Network (as of April 21, 2015)**

Description	Location	Telephone and facsimile No.
<b>NORTH AMERICA</b>		
MAYEKAWA CANADA INC. (VANCOUVER OFFICE)	12180 RIVERSIDE WAY, RICHMOND, B.C., V6W 1K5, CANADA	TEL: (1) 604-270-1544 FAX: (1) 604-270-9870
MAYEKAWA CANADA INC. (TORONTO OFFICE)	1745 BONHILL ROAD, UNIT #6&7 MISSISSAUGA, ONTARIO, L5T 1C1, CANADA	TEL: (1) 905-564-0664 FAX: (1) 905-564-7614
MAYEKAWA CANADA INC. (CALGARY OFFICE)	4525 6A STREET N.E., CALGARY, ALBERTA, T2E 4B2, CANADA	TEL: (1) 403-250-1554 FAX: (1) 403-250-1504
MAYEKAWA U.S.A. INC. (CHICAGO OFFICE)	1850 JARVICE AVENUE, ELK GROVE VILLAGE, IL 60007, U.S.A.	TEL: (1) 773-516-5070 FAX: (1) 773-516-5071
MAYEKAWA U.S.A. INC. (NEW YORK OFFICE)	250 WEST NYACK ROAD, SUITE 230, WEST NYACK, NY 10994, U.S.A.	TEL: (1) 914-301-9770 FAX: (1) 914-332-0400
MAYEKAWA U.S.A. INC. (HEAD QUARTERS) (NASHVILLE PLANT)	130 SMART PARK DRIVE, LEBANON, TN 37090, U.S.A.	TEL: (1) 615-773-2859 FAX: (1) 615-444-1995
MAYEKAWA U.S.A. INC. (LA OFFICE)	19475 GRAMERCY PLACE, TORRANCE, CA 90501, U.S.A.	TEL: (1) 310-328-1362 FAX: (1) 310-782-6759
MAYEKAWA U.S.A. INC. (SEATTLE OFFICE)	2615 W CASINO ROAD, UNIT-3D, EVERETT, WA 98204, U.S.A.	TEL: (1) 425-645-9400 FAX: (1) 425-353-3344
MAYEKAWA U.S.A. INC. (COVINA OFFICE)	1272 CENTER COURT DR, SUITE 106, COVINA, CA 91724, U.S.A.	TEL: (1) 626-598-5030 FAX: (1) -
MAYEKAWA U.S.A. INC. (SAN ANTONIO OFFICE)	1219 SAFARI, SAN ANTONIO, TX 78216, U.S.A.	TEL: (1) 210-599-4536 FAX: (1) 210-599-4538
MAYEKAWA U.S.A. INC. (YORK OFFICE)	3395 FARMTRAIL ROAD YORK, PA 17406, U.S.A.	TEL: (1) 717-779-0138 FAX: (1) 717-779-0109
MAYEKAWA U.S.A. INC. CHEMICAL PROCESS DIVISION (LA OFFICE & ANUFACTURING)	19475 GRAMERCY PLACE, TORRANCE, CA 90501, U.S.A.	TEL: (1) 310-328-6279 FAX: (1) 310-328-8487
MAYEKAWA U.S.A. INC. CHEMICAL PROCESS DIVISION (HUSTON SERVICE OFFICE)	3222 PASADENA FREEWAY PASADENA, TX 77503, U.S.A.	TEL: (1) 281-447-2599 FAX: (1) 281-447-6623
MAYEKAWA U.S.A. INC. CHEMICAL PROCESS DIVISION (HUSTON SALES & ENGINEERING OFFICE)	1770 ST. JAMES PLACE, SUITE 408, HOUSTON, TX 77056, U.S.A.	TEL: (1) 832-547-2320
<b>EUROPE and AFRICA</b>		
N.V.MAYEKAWA EUROPE S.A. (HEAD OFFICE, FACTORY)	LEUVENSESTEENWEG 605, 1930 ZAVENTEM, BELGIUM	TEL: (32) 2-757-9075 FAX: (32) 2-757-9023
MAYEKAWA DEUTSCHLAND GMBH	UNTER-BOHNHOF-STRASSE 38A, D-82110 GERMERING, DEUTSCHLAND	TEL:(49) 89-5527-989-0 FAX:(49)89-5527-989-19
MAYEKAWA DEUTSCHLAND GMBH (HUMBURG OFFICE)	WEIDESTRASSE 122A, 22083 HAMBURG, DEUTSCHLAND	TEL:(49)40-2788-9149-0 FAX:(49)40-2788-9149-9
N.V.MAYEKAWA EUROPE S.A.(UK)	16 OAKHURST GARDENS, BEXLEYHEATH, KENT DA7 5JP, UNITED KINGDOM	TEL: (44) 1322-433558 FAX: (44) 1322-433164



Description	Location	Telephone and facsimile No.
MAYEKAWA. S.L.	CALLE MONTEVIDEO 5, NAVE 13 POL. INDUSTRIAL CAMPORROSO 28806 ALCALA DE HENARES, MADRID, SPAIN	TEL: (34) 91-830-0392 FAX: (34) 91-830-0397
MAYEKAWA FRANCAISE SARL	9, RUE MICHAEL FARADAY, 78180 MONTIGNY-LE-BRETONNEUX, FRANCE	TEL: (33) 1-30-58-26-00 FAX: (33) 1-30-58-19-37
N.V. MAYEKAWA EUROPE MOSCOW REPRESENTATIVE OFFICE	KOROVY VAL ST., 7, OFFICE 228, 119049, MOSCOW, RUSSIA	TEL: (7) 499-230-01-76 FAX: (7) 499-230-21-12
MAYEKAWA-SVEDAN SP. Z O.O. (MPL)	UL. DRUSKIENICKA 8/10, 60-476 POZNAN, POLAND	TEL: (48) 61-842-0738 FAX: (48) 61-848-5837
MAYEKAWA INTERTEC AG	ROSENBERGSTRASSE 31, CH-6300 ZUG, SWITZERLAND	TEL: (41) 41-726-8626 FAX: (41) 41-726-8620
MAYEKAWA INTERTEC AG - EGYPT	P.O.BOX 341 NEW CAIRO - 5th SETTLEMENT, NORTH 90th St. THE 47th BUILDING - 4th FLOOR, OFFICE 419, EGYPT	TEL: (20) 22-503-2925 FAX: (20) 22-503-2801
MAYEKAWA INTERTECH AG - ABU DHABI	ALI & SONS BUSINESS CENTER OFFICE No.201 ALI KHALFAN RASHED AL MUTAWA AL DHAHIRI BLDG. PLOT No.29, AL AIN ROAD, UMM AL NAR, ABU DHABI U.A.E. P.O. BOX 129865	TEL: (971) 2-5102-451 FAX: (971) 2-5102-571
MAYEKAWA MIDDLE EAST FZCO	P.O.BOX 61349, PBU: RA08-UC05, JEBEL ALI FREE ZONE, DUBAI, U.A.E.	TEL: (971) 4-888-6363 FAX: (971) 4-888-6373
MAYEKAWA TURKEY SOGUTMA SANAYI VE TICARET LIMITED SIRKETI	ISTANBUL DUNYA TICARET MERKEZI A-2 BLOK KAT 10 No:325 YESILKOY 34149, ISTANBUL, TURKEY	TEL: (90) 212-4653631 FAX: (90) 212-4653635
N.V. MAYEKAWA EUROPE S.A. (BULGARIA)	24,KAMEN ANDREEV STR. 1303, SOFIA, BULGARIA	TEL: (359) 2-8910130 FAX: (359) 2-8910131
MAYEKAWA ITALIA S.R.L. (MILANO OFFICE)	VIA RICCARDO LOMBARDI 19/12, 20153 MILANO, ITALY	TEL: (39) 02-4892-9159 FAX: (39) 02-453-1728
MAYEKAWA ITALIA S.R.L. (BOLOGNA OFFICE)	VIA PRADAZZO 7,40012 CALDERARA DI RENO, BOLOGNA, ITALY	TEL: (39) 051-726-364 FAX: (39) 051-726-804
MAYEKAWA SOUTH AFRICA (PTY) LTD. (CAPE TOWN OFFICE)	WEST END, UNIT 3 PRIME PARK, PRINTERS WAY, MONTAGUE GARDENS 7441, REPUBLIC OF SOUTH AFRICA	TEL: (27) 21-551-1434 FAX: (27) 86-546-3618
<b>ASIA PACIFIC</b>		
MAYEKAWA AUSTRALIA PTY.LTD.	UNIT 2, 44 MCCAULEY STREET MATRAVILLE NSW 2036, AUSTRALIA	TEL: (61) 2-9695-7000 FAX: (61) 2-9695-7001
MAYEKAWA AUSTRALIA PTY. LTD.(NEW ZEALAND OFFICE)	UNIT 2, 30 TUI STREET, OTAHUHU, AUCKLAND 2024, NEW ZEALAND	TEL: (64) 9-276-2305 FAX: (64) 9-276-2306
MAYEKAWA INDIA PVT.LTD. (GURGAON OFFICE)	545, 1st FLOOR, SECTOR-20,VILLAGE DUNDAHERA GURAGAON-122016, HARYANA, INDIA	TEL: (91) 12-4651-0181 FAX: (91) 12-4651-0188

Description	Location	Telephone and facsimile No.
P.T.MAYEKAWA INDONESIA	GRAHA PRATAMA BUILDING, 9TH FLOOR JL. M.T. HARYONO KAV.15 JAKARTA 12810, INDONESIA	TEL: (62) 21-8370-9484 FAX: (62) 21-8370-9483
P.T.MAYEKAWA INDONESIA (MEDAN OFFICE)	JL. SUTRISNO No.274 MEDAN-20215, INDONESIA	TEL: (62) 61-7323627 FAX: (62) 61-7358848
P.T.MAYEKAWA INDONESIA (SURABAYA OFFICE)	BUMI MANDIARI BUILDING, 7TH FLOOR SUITE 702B, JL. JEND. BASUKI RACHMAT No. 129-137, SURABAYA-INDONESIA	TEL: (62) 31-531-6613 FAX: (62) 31-532-4341
MAYEKAWA (M) SDN. BHD.	No.3, JALAN PJU 3/50, SUNWAY DAMANSARA TECHNOLOGY PARK, 47810 PETALING JAYA, SELANGOR, MALAYSIA	TEL: (60) 3-78051406 FAX: (60) 3-78051409
MAYEKAWA PHILIPPINES CORP.	4/F UNIT A AND B SUNTREE TOWER, 13 MERALCO AVENUE, SAN ANTONIO, ORTIGAS CENTER, PASIG CITY 1605, PHILIPPINES	TEL: (63) 2-706-0473 FAX: (63) 2-706-0475
MAYEKAWA PHILIPPINES CORP. (GENERAL SANTOS OFFICE)	ROOM 4, LEAH DAPROZA BUILDING FISCAL DAPROZA AVENUE GENERAL SANTOS CITY 9500, PHILIPPINES	TEL: (63) 83-552-3282 FAX: (63) 83-301-2698
MAYEKAWA SINGAPORE PTE.LTD.	6 TAGORE LANE SINGAPORE 787470	TEL: (65) 6451-1565 FAX: (65) 6451-4932
MAYEKAWA (TAIWAN) CO., LTD. (KAOHSIUNG OFFICE)	No.2-1,XINZHAN RD.,QIANZHEN DIST., KAOHSIUNG CITY,80672 TAIWAN , ROC	TEL: (886) 7-821-0886 FAX: (886) 7-821-4688
MAYEKAWA (TAIWAN) CO., LTD. (CHEMICAL DEPARTMENT)	1F., NO.2, SHIN JANN ROAD, CHIEN CHEN DIST., KAOHSIUNG, TAIWAN 80672, ROC	TEL: (886) 7-812-7709 FAX: (886) 7-812-9019
MAYEKAWA (TAIWAN) CO., LTD. (TAIPEI HEAD OFFICE)	8F, NO, 421, SUNG-SHAN ROAD, TAIPEI, TAIWAN 11083, REP. OF CHINA	TEL: (886) 2-2727-9711 FAX: (886) 2-2759-8484
MAYEKAWA (TAIWAN) CO., LTD. (TAICHUNG BRANCH)	NO. 80-2, SEC.3, HUANJUNG RD., TAICHUNG, TAIWAN, 40755, REP. OF CHINA	TEL: (886) 4-2251-4128 FAX: (886) 4-2251-4129
MAYEKAWA CHINA INDUSTRIES CO., LTD. (SHANGHAI BRANCH)	ROOM 3001, NANZHENG BUILDING, NO.580 WEST NANJING RD., 200041 SHANGHAI, P.R. CHINA	TEL: (86) 21-5234-1988 FAX: (86) 21-5234-1788
MAYEKAWA CHINA MFG.CO., LTD.	201700 PLANT 1, NO.39, WEST XIQING ROAD, QINGPU, SHANHAI, P.R. CHINA	TEL: (86) 21-6920-7718 FAX: (86) 21-6920-7719
MAYEKAWA CHINA MFG.CO., LTD. (GUANGZHOU BRANCH)	RM.1205, TIANLHEFULI BUSINESS MANSION, No.4, HUA TING RD, GUANGZHOU, 510610, CHINA	TEL: (86) 20-8527-6161 FAX: (86) 20-8527-6165
MAYEKAWA CHINA MFG. CO., LTD. (QINGDAO BRANCH)	ROOM 601, FULIN BUILDING NO.87 SOUTH FUZHOU ROAD, SOUTH DISTRICT, QINGDAO CITY, 266071, CHINA	TEL: (86) 532-8602-6169 FAX: (86) 532-8602-6269

Description	Location	Telephone and facsimile No.
MAYEKAWA CHINA MFG. CO., LTD. (DALIAN BRANCH)	RM.A13-5, No.1 BUILDING, AREA A , WUCAI CITY, DALIAN ECO-TECH DEVELOPMENT ZONE, 116100, DALIAN, P. R. CHINA	TEL: (86) 411-8753-9620 FAX: (86)411-8757-9620
MAYEKAWA (THAILAND) CO., LTD. MAYEKAWA HOLDING (THAILAND)CO., LTD.	2/3 MOO 14, 3RD FLOOR BANGNA TOWER BLDG., TOWER A, BANGNA-TRAD RD, K.M.6.5, BANGKAEW BANGPLEE, SAMUTPRAKARN 10540, THAILAND	TEL: (66) 2-751-9610 FAX: (66) 2-751-9565
MAYEKAWA (THAILAND) CO., LTD. (TRANG BRANCH)	1/7 TRANG-PALIAN RD., MUANG, TRANG 92000, THAILAND	TEL: (66) 75-224-784 FAX: (66) 75-224-351
MAYEKAWA VIETNAM ONE MEMBER CO., LTD.	ROOM 305, 3FL, TUOI TRE TOWER, 60A HOANG VAN THU, WARD 9, PHU NHUAN DIST., HO CHI MINH CITY, VIETNAM	TEL: (84) 8-3997-5284 FAX: (84) 8-3997-5287
MYCOM KOREA CO., LTD. (HEAD OFFICE)	2F, 345, CHEONGRA-RO , YONGSAN-KU, SEOUL, 140-710, REP.OF KOREA	TEL: (82) 2-796-1766 FAX: (82) 2-798-7715
MYCOM KOREA CO., LTD. CHANGWON FACTORY	19, BANGYE-RO, UICHANG-KU, CHANGWON-SI, GYEONGSANGNAM-DO 641-847, REP.OF KOREA	TEL: (82) 55-294-8678 FAX: (82) 55-299-7678
MYCOM KOREA CO., LTD. (BUSAN BRANCH)	5F, 26, JUNGANG-DAERO, JUNG-GU, BUSAN 600-714, REP.OF KOREA	TEL: (82) 51-242-3737 FAX: (82) 51-243-8542
<b>LATIN AMERICA</b>		
MAYEKAWA ARGENTINA S.A. (BUENOS AIRES OFFICE)	DR. JOSE VALENTIN GOMEZ 151, LOT42, HAEDO-PARTIDO DE MORON, BUENOS AIRES, CP B1706FMA, ARGENTINA	TEL: (54) 11-4627-6660 FAX: (54) 11-4628-1511
MAYEKAWA ARGENTINA S.A. (PUERTO MADRYN OFFICE)	OFICINA PTO. MADRYN LEOPOLDO LUGONES 45 (U9129KDA)-PUERTO MADRYN PCIA DE CHUBUT REPUBLICA ARGENTINA	TEL: (54) 2965-475414 FAX: (54) 2965-475414
MYCOM PERU S.A.C.	CALLE LUIS PASTEUR 1490, LINCE, LIMA, PERU	TEL: (51) 1-205-5400 FAX: (51) 1-222-1543
MAYEKAWA CHILE S.A.C.el. (SANTIAGO OFFICE)	CORDILLERA No.331, MODULO D14, FLEX CENTER, PUERTO VESPUCCIO, QUILICURA, SANTIAGO, CHILE	TEL: (56) 2-739-0202 FAX: (56) 2-739-2700
MAYEKAWA CHILE S.A.C.el. (CONCEPCION OFFICE)	ANIBAL PINTO No.215, OFICINA 403, CONCEPCION, CHILE	TEL: (56) 41-223547 FAX: (56) 41-212443
MAYEKAWA CHILE S.A.C.el. (PUERTO MONTT OFFICE)	BERNARDINO 1057 MODULO 6, PARQUE INDUSTRIAL SAN ANDRES PUERTO MONTT, CHILE	TEL: (56) 65-257570 FAX: (56) 65-288073
MAYEKAWA ECUADOR S.A.	CALLE 15B Y AV. GUILLERMO PAREJA C.C.STEFANY LOCAL #4, CALLA.LA GARZOTA 1 MZ.28 SOLOR 13, GUAYAQUIL, ECUADOR	TEL: (593)4-262-9108 TEL: (593)4-262-6407 FAX: -
MAYEKAWA COLOMBIA S.A.S	TRANSVERSAL 93 NO.53-48 INTERIOR 37, PAQUE INDUSTRIAL EL DORADO, BOGOTA, COLOMBIA	TEL: (57) 1-430-9980 TEL: (57) 1-224-3028 FAX: (57) 1-437-0988

Description	Location	Telephone and facsimile No.
MAYEKAWA COLOMBIA S.A.S. (MEDELLIN OFFICE)	DIRECCION CR 43B No. 8 SUR 10 OFICINA 404 EDF. OVIEDO MEDELLIN, COLOMBIA	TEL: (57) 4-313-4343 FAX: (57) 4-313-4343
MAYEKAWA DO BRASIL EQIPAMENTOS INDUSTRIAIS LTDA.	RUA LICATEM 250, BLOCO B/C, JARDIM PEROVA-ARUJA-SP CEP:07428-280, BRASIL	TEL: (55) 11-4654-8000 FAX: (55) 11-4654-8002
MAYEKAWA DO BRASIL LTDA. (BAHIA BRANCH)	RUA DR. JOSE PEROBA, 275 - SALA 902 EDIFICIO METROPOLIS - BAIRRO STIEPE, SALVADOR – BA,CEP:41770-235, BRASIL	TEL: (55) 71-3341-0737 FAX: —
MAYEKAWA DO BRASIL EQIPAMENTOS INDUSTRIAIS LTDA. (CHAPECO BRANCH)	AV. NEREU RAMOS, 75D, SALA 503A, EDIFICIO CENTRO PROFISSIONAL CEP:89801-023 C.P.:177 CHAPECO-SC, BRASIL	TEL: (55) 49-3324-0681 FAX: (55) 49-3322-4241
MAYEKAWA DO BRASIL EQIPAMENTOS INDUSTRIAIS LTDA. (CUIABA BRANCH)	AVENIDA ISSAC POVOAS, 586 – SALA 405 EDIFICIO WALL STREET - CENTRO CUIABA-MT, CEP 78055-560, BRASIL	TEL: (55) 65-3023-7559 FAX: —
MAYEKAWA DO BRASIL EQIPAMENTOS INDUSTRIAIS LTDA. (CURITIBA BRANCH)	RUA XV DE NOVEMBRO, 2175 6 ANDAR SALA 30 SHOPPING CELLI CEP:83005-000 SAO JOSE DOS PINHAIS-PR, BRASIL	TEL: (55) 41-3383-1518 FAX: (55) 41-3383-1987
MAYEKAWA DO BRASIL EQIPAMENTOS INDUSTRIAIS LTDA. (GOIANIA BRANCH)	RUA C, 255 – QUADRA 588 – LOTE 4/8 SALA 104 – CENTRO EMPRESARIAL SEBBA GOIANIA-GO, CEP 74280-010, BRASIL	TEL: (55) 62-3093-5062 FAX: —
MAYEKAWA DO BRASIL EQIPAMENTOS INDUSTRIAIS LTDA. (OESTE PAULISTA BRANCH)	AV. FRANCISCO DE CHAGAS OLIVEIRA, 344 JARDIM PINHEIRO SAO JOSE DO RIO PRETO-SP, CEP 15091-330, BRASIL	TEL: (55) 17-3227-0235 FAX: (55) 17-3227-3120
MAYEKAWA DO BRASIL EQIPAMENTOS INDUSTRIAIS LTDA. (RECIFE BRANCH)	RUA AGENOR LOPES, 292 SALA 305 CEP:51021-110 BOA VIAGEM RECIFE-PE, BRASIL	TEL: (55) 81-3342-7670 FAX: —
MAYEKAWA DO BRASIL EQIPAMENTOS INDUSTRIAIS LTDA. (RIO GRANDE DO SUL BRANCH)	RUA MUCK, 298 – SALA 601 EDIFICIO SANTA HELENA CEP:92010-250 CANOAS-RS, BRASIL	TEL: (55) 51-3429-1860 FAX: (55) 51-3477-5212
MAYEKAWA DO BRASIL EQIPAMENTOS INDUSTRIAIS LTDA. (LINHARES BRANCH)	AV. GOVERNADOR CARLOS LINDENBERG, 873/107 CENTRO CEP:29900-020 LINHARES-ES, BRASIL	TEL: — FAX: —
MAYEKAWA DO BRASIL EQIPAMENTOS INDUSTRIAIS LTDA. (MACAE)	RUA PROFESSOR MARIETA PEIXOTO, 62 CENTRO - MACAE – RJ, CEP 27910-250, BRASIL	TEL: (55) 22-2772-6069 FAX: (55) 22-2759-3112
MAYEKAWA DO BRASIL EQIPAMENTOS INDUSTRIAIS LTDA. (RIO DE JANEIRO BRANCH)	AV.LUIZ CARLOS PRESTES, 350-SALA 313-EDIFICIO BARRA TRADE II, BARRA DA TIJUCA, RIO DE JANEIRO-RJ CEP:22775-055, BRASIL	TEL: (55) 21-2431-3600 FAX: (55) 21-2430-8882
MYCOM CENTROAMERICA S.A	BODEGA #63, CONDOMINIO COMERCIAL TIERRA DOS, EL CACIQUE DE RIO SEGUNDO, ALAJUELA, COSTA RICA	TEL: (506) 2441-4464 FAX: (506) 2441-4465

Description	Location	Telephone and facsimile No.
MYCOM VENEZUELA SALES & SERVICES,C.A. (CARACAS OFFICE)	CALLE LOS MANGOS, EDIFICIO SELEMAR, PISO 8, SABANA GRANDE, CARACAS, VENEZUELA	TEL: (58) 212-216-6026 FAX: (58) 212-216-0608
MYCOM VENEZUELA SALES & SERVICE, C.A. (MARACAY OFFICE)	AV.INTERCOMUNAL TURMERO, EDF.TECHOMAT METROPOLITANO, PISO 1, OFICINA 3, MARACAY, EDO.ARAGUA, VENEZUELA	TEL: (58) 243-269-4913 FAX: (58) 243-269-3952
MYCOM VENEZUELA SALES & SERVICE, C.A. (MARACAIBO OFFICE)	CALLE 148,CENTRO EMPRESARIAL SAN FRANCISCO NIVEL 1 LOCAL 5 Y 6, ZONA INDUSTRIAL ILETAPA,SAN FRANCISCO EDO.ZUILIA, VENEZUELA	TEL: (58) 261-418-1760 FAX: -
MYCOM VENEZUELA SALES & SERVICE, C.A. (BARCELONA OFFICE)	AV. MUNICIPAL DE PTO. LA CRUZ, EDIF. LOCAL NRO.57, PLANTA ALTA, MUNICIPIO SOTILLO, PUERTO LA CRUZ, VENEZUELA	TEL: (58) 261-765-1059
MYCOM CHEMICAL PROCESS CORP. DE VENEZUELA S.A.	CALLE 148,CENTRO EMPRESARIAL SAN FRANCISCO NIVEL 1 LOCAL 5 Y 6, ZONA INDUSTRIAL ILETAPA,SAN FRANCISCO EDO.ZUILIA, VENEZUELA	TEL: (58) 261-418-1760 FAX: -
MAYEKAWA DE MEXICO, S.A. DE C.V. (CUERNAVACA OFFICE)	AV.DE LOS 50MTS.NO.381, CIVAC. JIUTEPEC MORELOS, C.P.62578, MEXICO	TEL: (52) 77-73-19-0925 FAX: (52) 77-73-20-5762
MAYEKAWA DE MEXICO, S.A. DE C.V. (MEXICO CITY OFFICE)	AV.COYOACAN #945 COL .DEL VALLE DEL. BENITO JUAREZ C.P.03100, MEXICO, D.F. MEXICO	TEL: (52) 55-5062-0870 FAX: (52) 55-5062-0898
MAYEKAWA DE MEXICO, S.A. DE C.V. (GUADALAJARA OFFICE)	SANTA MARIA No.3086, COL. VALLARTA SAN LUCAS GUADALAJARA, JALISCO, C.P.44690, MEXICO	TEL: (52) 3336-15-5765 FAX: (52) 3336-15-1307
MAYEKAWA DE MEXICO, S.A. DE C.V. (MONTERREY OFFICE)	AV.CHAPULTEPEC NO.2233 OTE. FRACC, BUENOS AIRES MONTERREY N.L. C.P.64800, MEXICO	TEL: (52) 81-8347-3085 FAX: (52) 81-8347-5830
MAYEKAWA DE MEXICO, S.A. DE C.V. (HERMOSILLO OFFICE)	CALLE FRAY TORIBIO DE BENAVENTE #38 COL. LOS ARCOS CD. HERMOSILLO, SONORA, C.P.83250, MEXICO	TEL: (52) 662-216-2047 FAX: (52) 662-216-2047
MAYEKAWA DE MEXICO, S.A. DE C.V. (IRAPUATO OFFICE)	CALLE AGUSTIN ZARAGOZA NO.219 LOCAL-2 COL.DEPORTIVA, C.P.36612, IRAPUATO, GTO. MEXICO	TEL: (52) 462-624-9353 FAX: (52) 462-624-9264
MAYEKAWA DE MEXICO, S.A. DE C.V. (CULIACAN OFFICE)	AV. NICOLAS BRAVO 1572, LOCAL 1 COL.MORELOS CULIACAN, SINALOA, C.P.80170, MEXICO	TEL: (52) 66-7715-4199 FAX: (52) 66-7715-4150
MAYEKAWA DE MEXICO, S.A. DE C.V. (VILLAHERMOSA OFFICE)	CERRADA DE RIO AMATAN 106-A COL. CASA BLANCA PRIMERA SECCION, VILLAHERMOSA, TABASCO, C.P.86060, MEXICO	TEL: (52) 993-315-4025



**MAYEKAWA MFG. CO., LTD.**

3-14-15 Botan, Koto-ku, Tokyo 135-8482

TEL : 03-3642-8181

URL : <http://www.mayekawa.com/>



---